

# 3

## Contactors

Series  
C137, C163, C164, C165

Single pole contactors  
for battery voltages

Catalogue B60.en

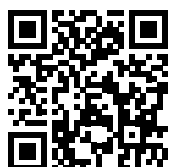

More information  
[schaltbau.com](http://schaltbau.com)

**C137, C163, C164, C165\* – Contactors for battery voltages**

With its proven line of C137, C163, C164 and C165\* series contactors Schaltbau offers a scalable solution for handling direct current loads in the range of 40 A to 220 A for the most common coil voltages up to 120 V.

When utilizing a contactor its coil is powered by a battery and a magnetic field is generated around its armature by the direct current voltage coming from the battery. That is why Schaltbau battery contactors feature extra wide coil tolerance. They have double-break contacts, are compact in size, economical in price, and known for their reliability.

Version »C« are single-pole NO contactors with magnetic blowout, whereas version »H« are single-pole change-over contactors which feature an additional, electrically separated contact element. This extra normally

closed contact is, however, without blowout magnets and not designed to make and break current.

Bistable versions: C163 series contactors are also available with magnetic latching. The change towards one of the two bistable positions of the main contact is operated by a pulse of 100 msec. duration. The coil consumes no power except for the short pulse necessary to close and reopen the main contact, see also catalogue B164.en.

\* C165 only for spare parts requirements / no new projects

**Features**

- Rugged, compact design
- Four different sizes
- Double breaking main contacts
- Extra wide coil tolerance for industrial and railway applications in accordance with VDE and UIC standards

**Applications**

- General purpose motor control contactor
- Starting lift/lower controls as well as speed and directional controls of industrial trucks
- Heater and air conditioning control of electric locomotives and multiple units
- Battery powered electric functions in passenger coaches
- Deep discharge protection for batteries of uninterruptible power supplies (UPS)

**Standards**

Meet requirements for industrial applications to:

- **IEC 60947-1** Low-voltage switchgear and controlgear – Part 1: General rules
- **IEC 60947-4-1** Low-voltage switchgear and controlgear – Part 4-1: Contactors and motor starters – Electromechanical contactors and motor starters.
- **DIN EN 1175-1** Safety of industrial trucks – Electrical requirements – Part 1: General requirements for battery powered trucks

Meet requirements for railway applications to:

- **IEC 60077-1** Railway applications – Electric equipment for rolling stock - Part 1: General service conditions and general rules.
- **IEC 60077-2** Railway applications – Electric equipment for rolling stock - Part 2: Electrotechnical components; General rules

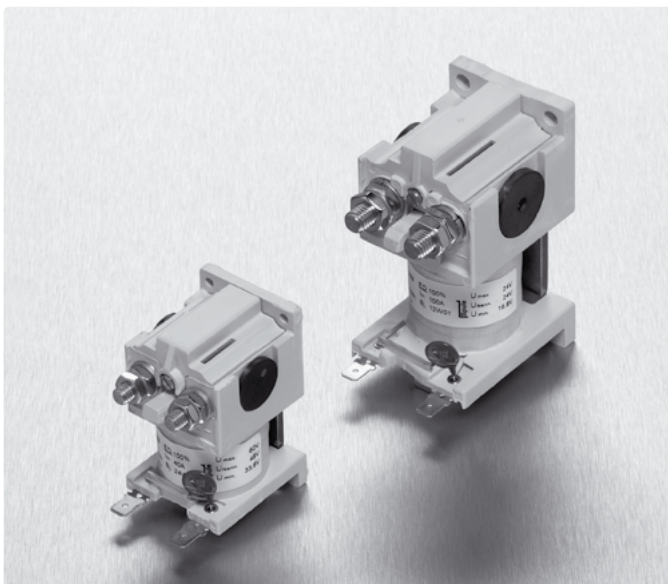

C137 and C163 series contactors

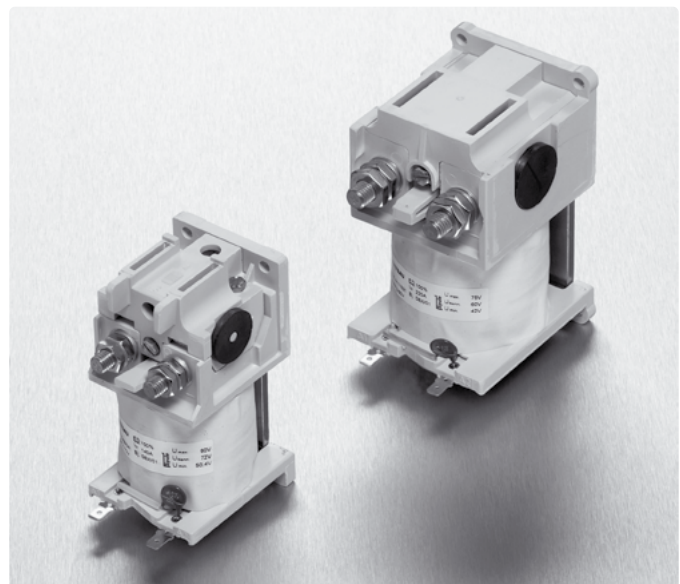

C164 and C165 series contactors

## Ordering code

C137, C163, C164, C165 series

### • C137 series

Example: **C137 C/ 24EV-V1**

**Series** C137 Single pole contactor

**Contact configuration**  
 C SPST NO \*1  
 H SPDT \*2

**Coil voltage**  
 24 / 36 / 48 / 72 / 80 / 110 V DC

**Coil tolerance**  
 R -30 % ... +10 % U<sub>s</sub> for industrial applications  
 E -30 % ... +25 % U<sub>s</sub> for railway applications

**Coil suppression**  
 X w/o for industrial applications  
 V varistor for railway applications

**Aux. contacts, Configuration and number of**  
 [-] w/o  
 V1 microswitch, SPDT \*3, 1x

**Stock items:**

SPST NO contactors		SPDT contactors	
C137 C/ 24RX	C137 C/ 24EV	C137 H/ 24RX	C137 H/ 24EV
C137 C/ 48RX	C137 C/ 36EV	C137 H/ 80RX	C137 H/110EV
C137 C/ 80RX	C137 C/ 48EV		
	C137 C/ 72EV		
	C137 C/110EV		

### • C163 series

Example: **C163 C/ 24EV-R1**

**Series** C163 Single pole contactor

**Contact configuration**  
 C SPST NO \*1  
 H SPDT \*2

**Coil voltage**  
 24 / 36 / 48 / 72 / 80 / 110 V DC

**Coil tolerance**  
 R -30 % ... +10 % U<sub>s</sub> for industrial applications  
 E -30 % ... +25 % U<sub>s</sub> for railway applications

**Coil suppression**  
 X w/o for industrial applications  
 V varistor for railway applications

**Aux. contacts, Configuration and number of**  
 [-] w/o  
 R1 S840, SPDT \*3, 1x

**Stock items:**

SPST NO contactors		SPDT contactors	
C163 C/ 24RX	C163 C/ 24EV	C163 H/ 24RX	
C163 C/ 48RX	C163 C/ 36EV		
C163 C/ 80RX	C163 C/ 48EV		
	C163 C/ 72EV		
	C163 C/110EV		

### • C164 series

Example: **C164 C/ 24EV-R1**

**Series** C164 Single pole contactor

**Contact configuration**  
 C SPST NO \*1  
 H SPDT \*2

**Coil voltage**  
 24 / 36 / 48 / 72 / 80 / 110 V DC

**Coil tolerance**  
 R -30 % ... +10 % U<sub>s</sub> for industrial applications  
 E -30 % ... +25 % U<sub>s</sub> for railway applications

**Coil suppression**  
 X w/o for industrial applications  
 V varistor for railway applications

**Aux. contacts, Configuration and number of**  
 [-] w/o  
 R1 S840, SPDT \*3, 1x

**Stock items:**

SPST NO contactors		SPDT contactors	
C164 C/ 24RX	C164 C/ 24EV	C164 H/ 24RX	
C164 C/ 48RX	C164 C/ 48EV	C164 H/ 48RX	
C164 C/ 80RX	C164 C/ 72EV	C164 H/ 80RX	
	C164 C/110EV		

### • C165 series [only for spare parts requirements / no new projects]

Example: **C165 C/ 24EV-R1**

**Series** C165 Single pole contactor

**Contact configuration**  
 C SPST NO \*1  
 H SPDT \*2

**Coil voltage**  
 24 / 36 / 48 / 72 / 80 / 110 V DC

**Coil tolerance**  
 R -30 % ... +10 % U<sub>s</sub> for industrial applications  
 E -30 % ... +25 % U<sub>s</sub> at 55° C for railway applications  
 (-30 % ... +15 % U<sub>s</sub> at 70° C)

**Coil suppression**  
 X w/o for industrial applications  
 V varistor for railway applications

**Aux. contacts, Configuration and number of**  
 [-] w/o  
 R1 S840, SPDT \*3, 1x

**Stock items:**

SPST NO contactors		SPDT contactors	
C165 C/ 24RX	C165 C/ 24EV	C165 H/ 24RX	
C165 C/ 48RX	C165 C/ 48EV		
C165 C/ 80RX	C165 C/ 72EV		
	C165 C/110EV		

**Note:**  
 Presented in this catalogue are only stock items which can be supplied in short delivery time. Types for AC operation are available on special order: AC variants on request, version then: B = normally open contact without blowout; G = changeover contact without blowout.

**Special variants:**  
 If you need a special variant feel free to contact us. Maybe the type of contactor you are looking for is among our many special designs. If not, we can also supply customized designs. In this case, however, minimum order quantities apply.

\*1 Version C are NO contactors fitted with permanent magnets. The normally open (make) contact is designed to make and break current like an open style power relay.  
 \*2 Version H changeover contactors feature electrically separated potential carrying make and break contacts. Please note that here only the normally open (make) contact is capable of switching current loads, whereas the normally closed (break) contact is designed to carry current but not to make and break current.  
 \*3 One microswitch max., with silver plated contacts

**Specifications** for industrial applications

## C137, C163, C164, C165 series

Series		C137 x/ xxRx-xx	C163 x/ xxRx-xx	C164 x/ xxRx-xx	[C165 x/ xxRx-xx]**
Type of voltage		DC, AC *1			
Main contacts, Number of, Configuration		1x SPST-NO or 1x SPDT *2			
<b>General electrical ratings of main circuit to IEC 60947</b>					
Nominal voltage $U_n$		110 V			
Rated insulation voltage $U_i$		150 V			
Rated impulse withstand voltage $U_{imp}$		2.5 kV			
Pollution degree Overvoltage category		PD3 OV3			
Conventional thermal current $I_{th}$		50 A	100 A	140 A	220 A
Making capacity, resistive	T = 1 ms	600 A	800 A	1,000 A	2,000 A
Breaking capacity, T < 1 ms	NO CO*2	200 A @ 80 V DC 100 A @ 80 V DC	300 A @ 80 V DC 200 A @ 80 V DC	500 A @ 80 V DC 300 A @ 80 V DC	1,500 A @ 80 V DC 800 A @ 80 V DC
Rated short-time withstand current $I_{cw}$		800 A @ 100 ms	1,000 A @ 100 ms	1,500 A @ 100 ms	2,500 A @ 100 ms
switch-off, no reversing		only in one direction			
<b>Main contacts</b>					
Contact material	NO NC	AgSnO <sub>2</sub> AgNi	AgSnO <sub>2</sub> AgNi	AgSnO <sub>2</sub> AgNi	AgSnO <sub>2</sub> AgNi
Main terminals / tightening torque		M6 / 3 Nm max.	M8 / 6 Nm max.	M8 / 6 Nm max.	M10 / 10 Nm max.
<b>Auxiliary contacts</b>					
Number of / Configuration		1x SPDT	1x Snap-action switch S840 (SPDT)		
Switching capacities	T = 0 ms	2.5 A @ 24 V DC 1.0 A @ 48 V DC 0.5 A @ 80 V DC	2.5 A @ 24 V DC 1.0 A @ 48 V DC 0.5 A @ 80 V DC		
Terminals, Flat tabs		2.0 x 0.5 mm	6.3 x 0.8 mm		
<b>Magnetic drive</b>					
Coil voltage $U_s$		24 V ... 110 V DC	24 V ... 110 V DC	24 V ... 110 V DC	24 V ... 110 V DC
Coil tolerance		-30 % ... +10 % $U_s$	-30 % ... +10 % $U_s$	-30 % ... +10 % $U_s$	-30 % ... +10 % $U_s$
Coil power dissipation at $U_s$ @ $T_a = 20^\circ\text{C}$		12 W	18 W	20 W	27 W
Coil suppression		---	---	---	---
Coil terminals	Flat tabs	6.3 x 0.8 mm	6.3 x 0.8 mm	6.3 x 0.8 mm	6.3 x 0.8 mm
<b>Degree of protection</b>					
IP00					
Mechanical endurance	operating cycles	NO > 3m NC > 2m	> 3m	> 3m	> 3m
Electrical endurance	operating cycles	> 100,000 ( $U_n$ , $I_{th}$ , T < 1 ms, cycle ≤ 6/min)			
Vibration / Shock	EN 61373	Class B, Cat. 1: 5 ... 150 Hz / 5 g (30 msec., half sinus)			
<b>Mounting position</b>					
Horizontal: contact studs must point upwards Vertical: plasma exits must point upwards					
Temperature	Ambient temperature $T_a$ Storage temperature	-25 °C ... +50 °C -40 °C ... +85 °C			
Weight		220 g ... 250 g	550 g ... 680 g	960 g ... 1,050 g	1,900 g ... 2,150 g

\*\* Only for spare parts requirements / no new projects

\*1 Types for AC applications available on special order: Replace version C with B (= NO contactor without blowout); and version H with G (= changeover contactor without blowout), see ordering code on page 3

\*2 Changeover contactors: NO for load switching, with magnetic blowout; NC for non load switching without magnetic blowout.

**Specifications** for railway applications

C137, C163, C164, C165 series

Series		C137 x/ xxEx-xx	C163 x/ xxEx-xx	C164 x/ xxEx-xx	[C165 x/ xxEx-xx]**
Type of voltage		DC, AC *1			
Main contacts, Number of, Configuration		1x SPST-NO or 1x SPDT *2			
<b>General electrical ratings of main circuit to IEC 60077</b>					
Nominal voltage $U_n$		120 V			
Rated insulation voltage $U_i$		150 V			
Rated impulse withstand voltage $U_{imp}$		2,5 kV			
Pollution degree		PD3			
Overvoltage category		OV3			
Conventional thermal current $I_{th}$	NO NC *2	40 A 40 A	80 A 60 A	140 A 140 A	220 A 220 A
Making capacity, resistive	T = 1 ms	400 A	600 A	800 A	1.500 A
Breaking capacity, T < 1 ms	NO CO*2	150 A @ 80 V DC 60 A @ 80 V DC	250 A @ 80 V DC 150 A @ 80 V DC	400 A @ 80 V DC 250 A @ 80 V DC	1,500 A @ 80 V DC 800 A @ 80 V DC
Rated short-time withstand current $I_{cw}$		700 A @ 100 ms	800 A @ 100 ms	1,000 A @ 100 ms	2,000 A @ 100 ms
switch-off, no reversing		only in one direction			
<b>Main contacts</b>					
Contact material	NO NC	AgSnO <sub>2</sub> AgNi	AgSnO <sub>2</sub> AgNi	AgSnO <sub>2</sub> AgNi	AgSnO <sub>2</sub> AgNi
Main terminals / tightening torque		M6 / 3 Nm max.	M8 / 6 Nm max.	M8 / 6 Nm max.	M10 / 10 Nm max.
<b>Auxiliary contacts</b>					
Number of / Configuration		1x SPDT	1x Snap-action switch S840 (SPDT)		
Switching capacities	T = 0 ms	2.5 A @ 24 V DC 1.0 A @ 48 V DC 0.5 A @ 80 V DC	2.5 A @ 24 V DC 1.0 A @ 48 V DC 0.5 A @ 80 V DC		
Terminals, Flat tabs		2.0 x 0.5 mm	6.3 x 0.8 mm		
<b>Magnetic drive</b>					
Coil voltage $U_s$		24 V ... 110 V DC	24 V ... 110 V DC	24 V ... 110 V DC	24 V ... 110 V DC
Coil tolerance		-30 % ... +25 % $U_s$	-30 % ... +25 % $U_s$	-30 % ... +25 % $U_s$	-30 % ... +25 % $U_s$ *3
Coil power dissipation at $U_s$ @ $T_a = 20$ °C		8 W	12 W	12 W	23 W
Coil suppression		Varistor	Varistor	Varistor	Varistor
Coil terminals	Flat tabs	6.3 x 0.8 mm	6.3 x 0.8 mm	6.3 x 0.8 mm	6.3 x 0.8 mm
<b>Degree of protection</b>					
IP00					
Mechanical endurance	operating cycles	NO > 3m NC > 2m	> 3m	> 3m	> 3m
Electrical endurance	operating cycles	> 100,000 ( $U_n, I_{th}, T < 1$ ms, cycle $\leq$ 6/min)			
Vibration / Shock	EN 61373	Class B, Cat. 1: 5 ... 150 Hz / 5 g (30 msec., half sinus)			
<b>Mounting position</b>					
Horizontal: contact studs must point upwards Vertical: plasma exits must point upwards					
Temperature	Ambient temperature $T_a$ Storage temperature	-25 °C ... +70 °C -40 °C ... +85 °C			
Weight		220 g ... 250 g	550 g ... 680 g	960 g ... 1,050 g	1,900 g ... 2,150 g



\*\* Only for spare parts requirements / no new projects

\*1 Types for AC applications available on special order: Replace version C with B (= NO contactor without blowout); and version H with G (= changeover contactor without blowout), see ordering code on page 3.

\*2 Changeover contactors: NO for load switching, with magnetic blowout; NC for non load switching without magnetic blowout.

\*3 @ -25°C ... +55°C

**C137 SPST-NO or SPDT contactor**

C137 series

• **Device outline: C137 series SPST-NO contactor**

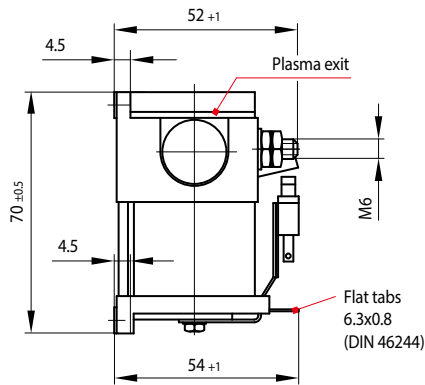
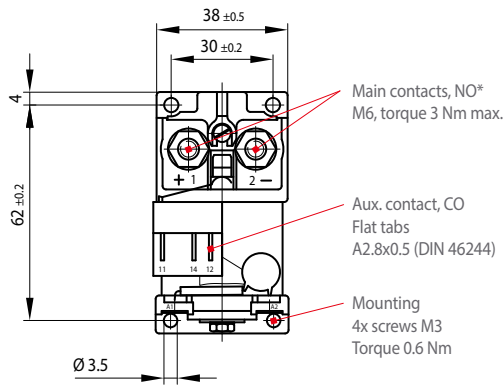

• **Circuit diagram**

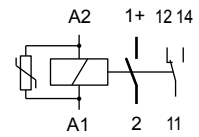

**Note:**  
Fitted with varistor and auxiliary contact, see ordering code on page 3.

\* SPST-NO contactor:  
NO for load switching,  
with magnetic blowout

• **Device outline: C137 series SPDT contactor**

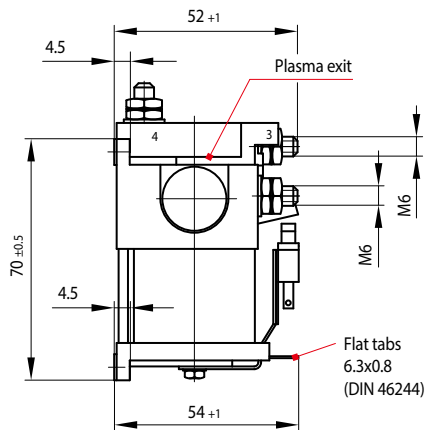
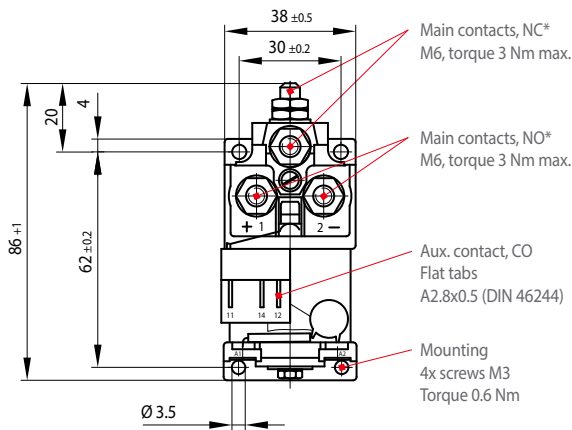

• **Circuit diagram**

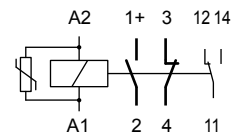

**Note:**  
Fitted with varistor and auxiliary contact, see ordering code on page 3.

\* SPDT contactors:  
NO for load switching, with  
magnetic blowout;  
NC for non load switching  
without magnetic  
blowout.

**HK-C137 Auxiliary contact**

C137 series

• **Auxiliary contact assembly HK-C137**



• **Mounting:**

C137 series contactors can be retrofitted with an auxiliary contact. Loosen the M4 hex screw a little that connects the yoke to the magnet core. Slide slotted mounting bracket of auxiliary contact assembly under screw head. Push yoke against housing and retighten screw.

**Characteristic curves** Contact performance

**Dimensioning, mounting instructions**

C137 series

• **Continuously rated, normally open contact**

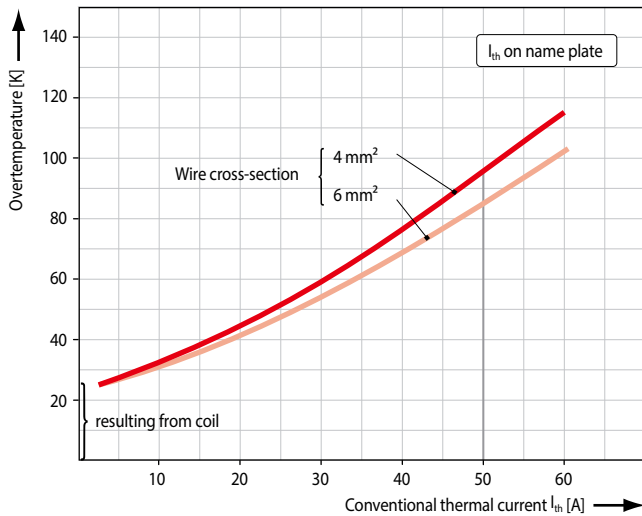

• **Continuously rated, normally closed contact**

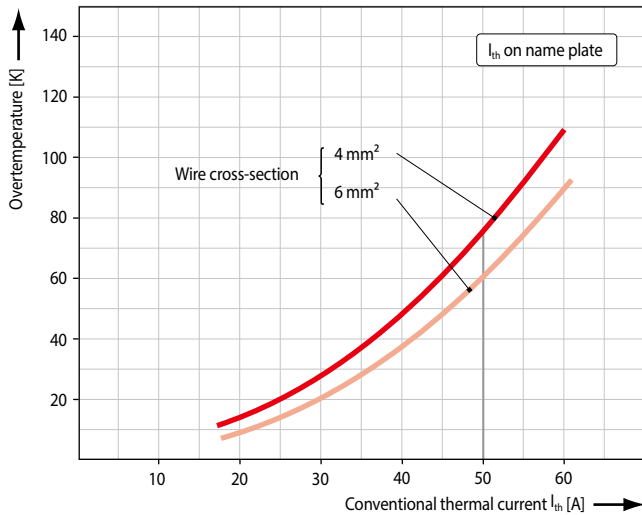

• **Max. breaking capacity DC of NO contact for coil tolerance R and E**

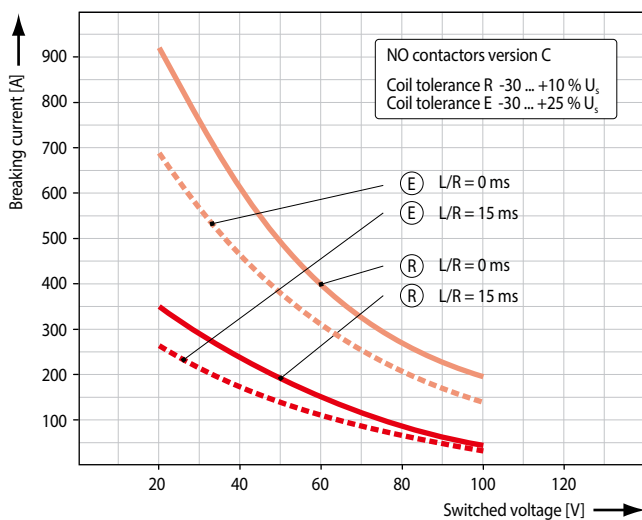

- Note:**
- The maximum breaking capacity is the value of prospective current at a stated DC voltage which can be ruptured by the contactor where the ensuing arc upon contact separation is still being quenched. For actual operation the current rating of the contactor should, therefore, be limited to 20 % ... 60 % of its maximum breaking capacity.
  - Please note that for double throw contactors, in addition to the foregoing limitations, the switch off load of the normally open contact must be further reduced by 30 % to 50 %.

• **Guide to permissible current rating**

Short-time duty	SPST-NO		SPDT			
			NO contact		NC contact	
Coil tolerance*	R	E	R	E	R	E
6 sec	250 A	180 A	250 A	180 A	200 A	140 A
1 min	120 A	90 A	120 A	90 A	110 A	75 A
3 min	100 A	70 A	100 A	70 A	90 A	60 A
5 min	80 A	60 A	80 A	60 A	70 A	50 A
10 min	70 A	50 A	70 A	50 A	60 A	---

Above current ratings refer to wire cross-section 6 mm<sup>2</sup>

\* Coil voltage tolerance  
**R:** -30 % ... +10 % U<sub>s</sub>  
**E:** -30 % ... +25 % U<sub>s</sub>



**Note:**

- The thermal current rating for continuous duty is dependent on the upper limiting temperature of the contact elements which must not exceed 150°C. Wire gauge, ambient temperature, duty and operating cycles, contamination of contacts and contact wear are all factors that influence the surface temperature rise of the contact studs. All the above current ratings should, therefore, be considered as a guide only.
- The way you mount the contactor has no less an impact on the rise of temperature and the insulation of the switching device. So please observe the clearance between live and earthed parts and comply with the safety regulations of the applicable standards. No liability will be accepted by Schaltbau in any circumstances for indirect damage resulting from clearances not being observed, devices not mounted properly, or products tampered with in any way.

• **Possible mounting orientations**

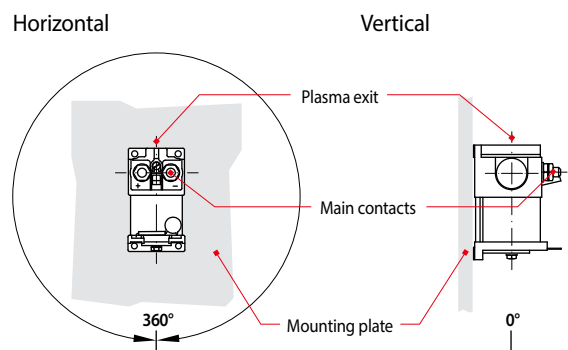

**Mounting positions:**

- Horizontal: contact studs must point upwards or
- Vertical: plasma exits must point upwards



**C163 SPST-NO or SPDT contactor**

C163 series

• **Device outline: C163 series SPST-NO contactor**

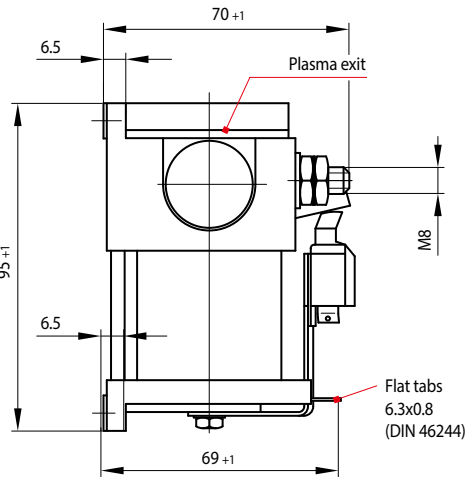
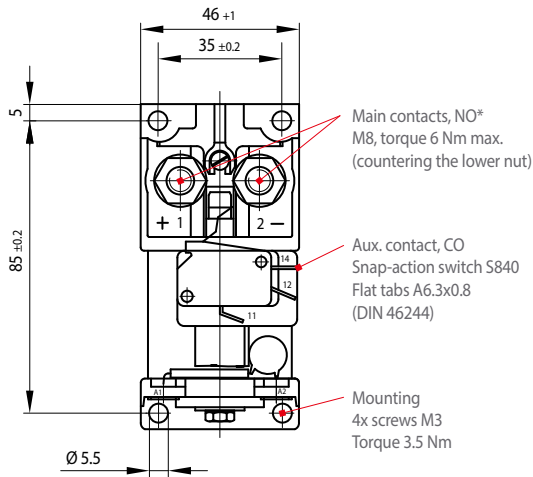

• **Circuit diagram**

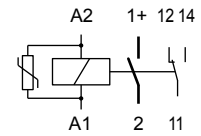

**Note:**  
Fitted with varistor and auxiliary contact, see ordering code on page 3.

\* SPST-NO contactor:  
NO for load switching,  
with magnetic blowout

• **Device outline: C163 series SPDT contactor**

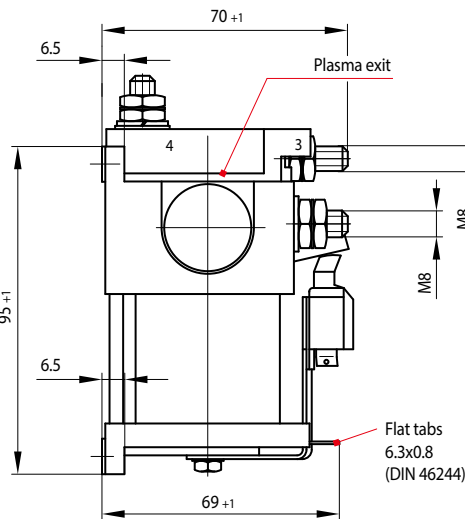
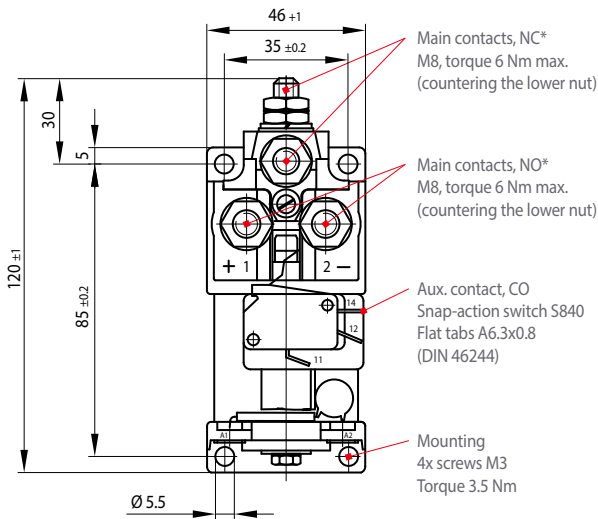

• **Circuit diagram**

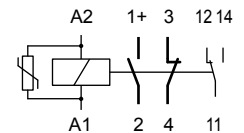

**Note:**  
Fitted with varistor and auxiliary contact, see ordering code on page 3.

\* SPDT contactors:  
NO for load switching, with  
magnetic blowout;  
NC for non load switching  
without magnetic  
blowout.

**HK-C163 Auxiliary contact**

C163 series

• **Auxiliary contact assembly HK-C163**



• **Mounting:**

C163 series contactors can be retrofitted with an auxiliary contact. Loosen the M5 hex screw a little that connects the yoke to the magnet core. Slide slotted mounting bracket of auxiliary contact assembly under screw head. Push yoke against housing and retighten screw.



**Characteristic curves** Contact performance

**Dimensioning, mounting instructions**

C163 series

• **Continuously rated, normally open contact**

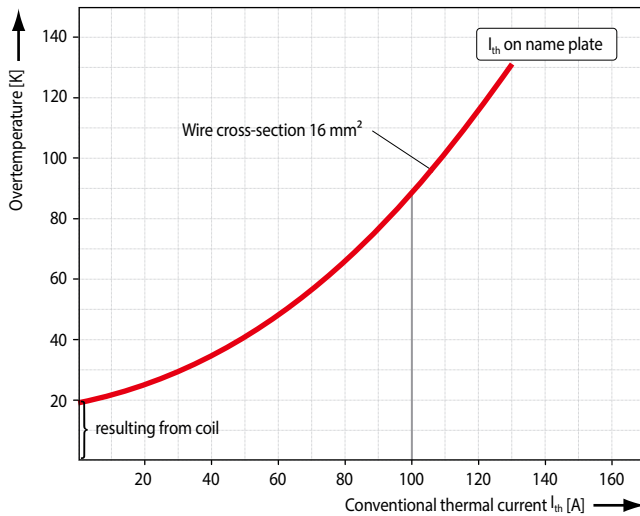

• **Continuously rated, normally closed contact**

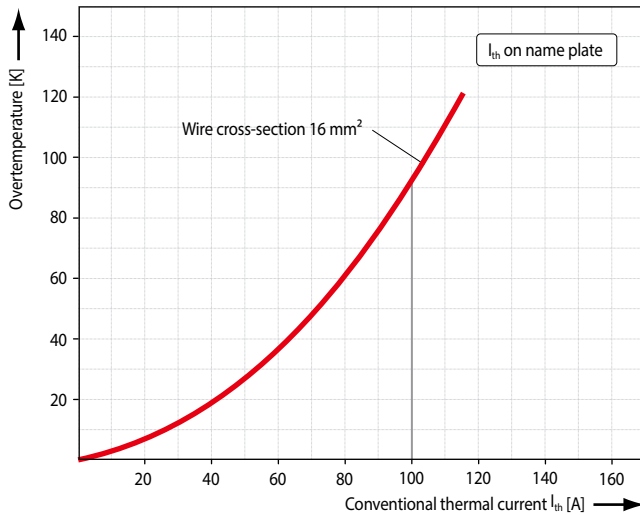

• **Max. breaking capacity DC of NO contact for coil tolerance R and E**

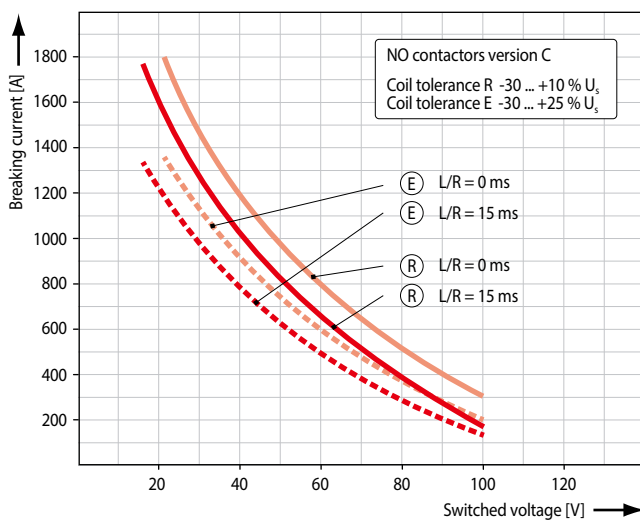

**Note:**

- The maximum breaking capacity is the value of prospective current at a stated DC voltage which can be ruptured by the contactor where the ensuing arc upon contact separation is still being quenched. For actual operation the current rating of the contactor should, therefore, be limited to 20 % ... 60 % of its maximum breaking capacity.
- Please note that for double throw contactors, in addition to the foregoing limitations, the switch off load of the normally open contact must be further reduced by 30 % to 50 %.

• **Guide to permissible current rating**

Short-time duty	SPST-NO		SPDT			
			NO contact		NC contact	
Coil tolerance*	R	E	R	E	R	E
6 sec	450 A	340 A	450 A	340 A	250 A	180 A
1 min	200 A	150 A	200 A	150 A	150 A	110 A
3 min	150 A	115 A	150 A	115 A	125 A	90 A
5 min	130 A	100 A	130 A	100 A	115 A	80 A
10 min	110 A	---	110 A	---	105 A	70 A

Above current ratings refer to wire cross-section 16 mm<sup>2</sup>

\* Coil voltage tolerance  
**R:** -30 % ... +10 % U<sub>s</sub>  
**E:** -30 % ... +25 % U<sub>s</sub>



**Note:**

- The thermal current rating for continuous duty is dependent on the upper limiting temperature of the contact elements which must not exceed 150°C. Wire gauge, ambient temperature, duty and operating cycles, contamination of contacts and contact wear are all factors that influence the surface temperature rise of the contact studs. All the above current ratings should, therefore, be considered as a guide only.
- The way you mount the contactor has no less an impact on the rise of temperature and the insulation of the switching device. So please observe the clearance between live or earthed parts and comply with the safety regulations of the applicable standards. No liability will be accepted by Schaltbau in any circumstances for indirect damage resulting from clearances not being observed, devices not mounted properly, or products tampered with in any way.

• **Possible mounting orientations**

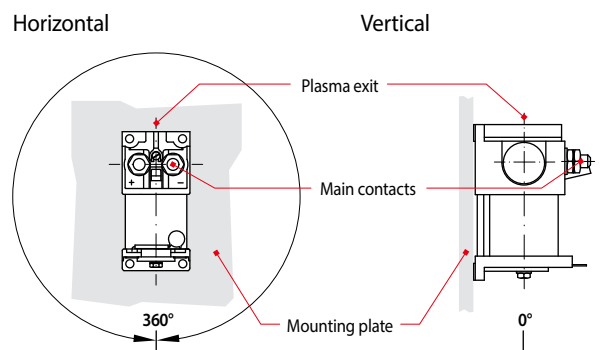

**Mounting positions:**

- Horizontal: contact studs must point upwards or
- Vertical: plasma exits must point upwards

**C164 SPST-NO or SPDT contactor**

C164 series

• **Device outline: C164 series SPST-NO contactor**

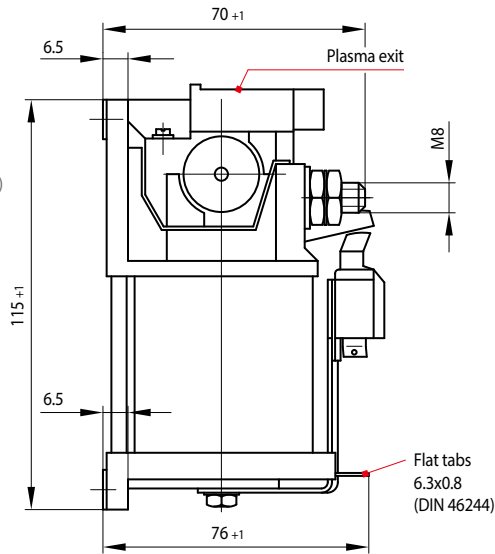
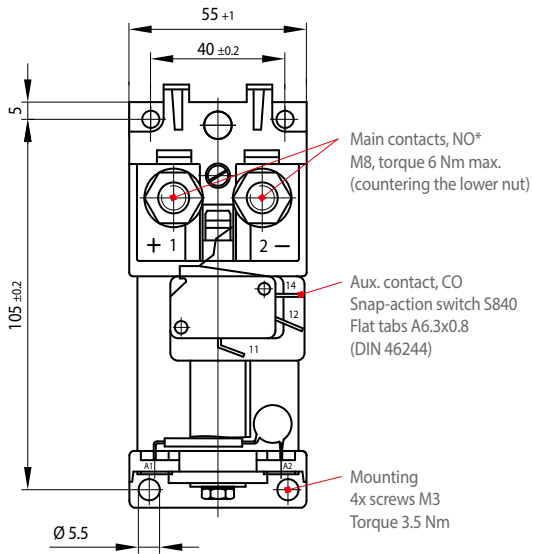

• **Circuit diagram**

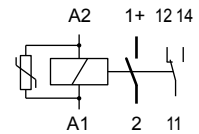

**Note:**  
Fitted with varistor and auxiliary contact, see ordering code on page 3.

\* SPST-NO contactor:  
NO for load switching,  
with magnetic blowout

• **Device outline: C164 series SPDT contactor**

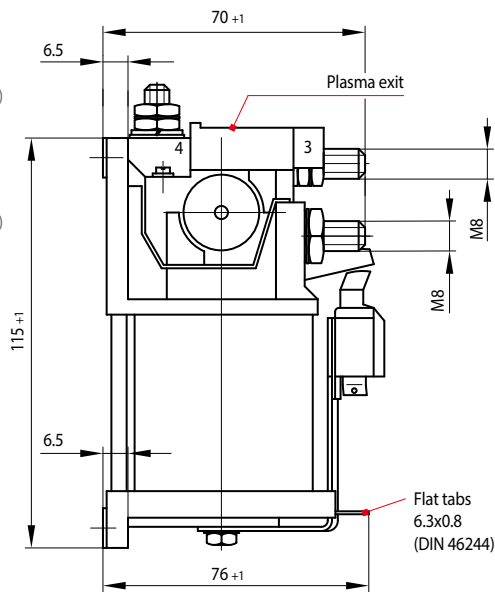
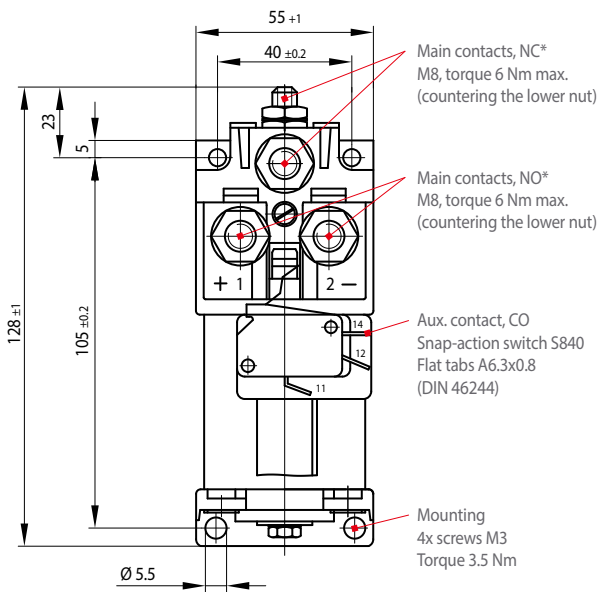

• **Circuit diagram**

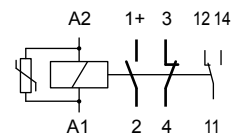

**Note:**  
Fitted with varistor and auxiliary contact, see ordering code on page 3.

\* SPDT contactors:  
NO for load switching, with  
magnetic blowout;  
NC for non load switching  
without magnetic  
blowout.

**HK-C164 Auxiliary contact**

C164 series

• **Auxiliary contact assembly HK-C164**



• **Mounting:**

C164 series contactors can be retrofitted with an auxiliary contact. Loosen the M5 hex screw a little that connects the yoke to the magnet core. Slide slotted mounting bracket of auxiliary contact assembly under screw head. Push yoke against housing and retighten screw.

**Characteristic curves** Contact performance

**Dimensioning, mounting instructions**

C164 series

• **Continuously rated, normally open contact**

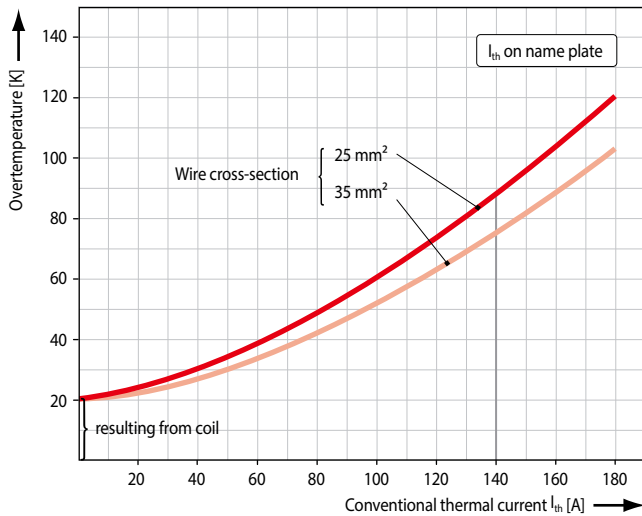

• **Continuously rated, normally closed contact**

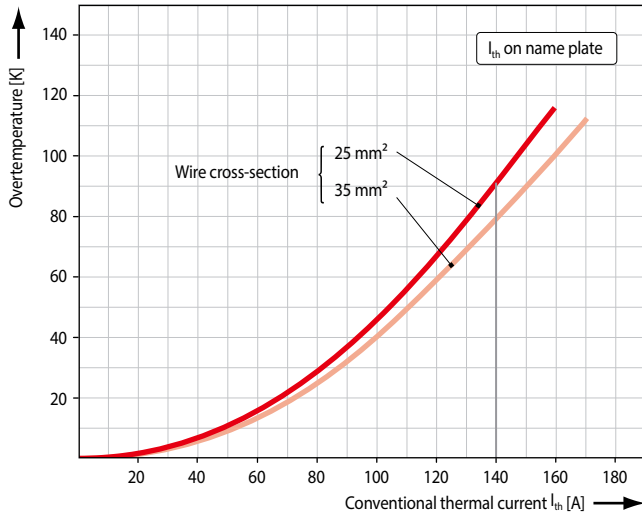

• **Max. breaking capacity DC of NO contact for coil tolerance R and E**

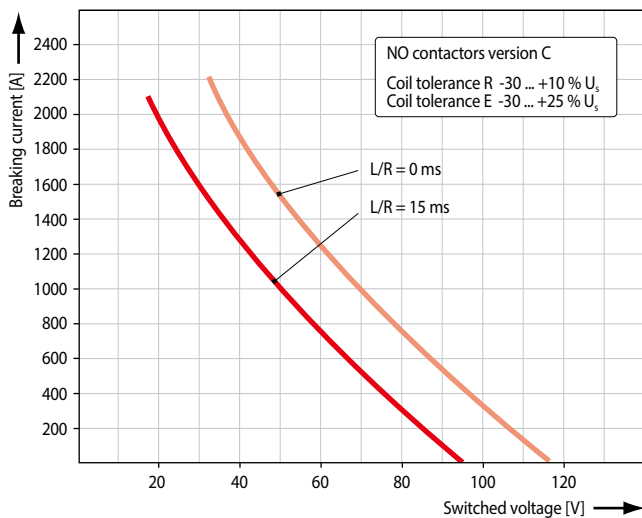

**Note:**

- The maximum breaking capacity is the value of prospective current at a stated DC voltage which can be ruptured by the contactor where the ensuing arc upon contact separation is still being quenched. For actual operation the current rating of the contactor should, therefore, be limited to 20 % ... 60 % of its maximum breaking capacity.
- Please note that for double throw contactors, in addition to the foregoing limitations, the switch off load of the normally open contact must be further reduced by 30 % to 50 %.

• **Guide to permissible current rating**

Short-time duty	SPST-NO		SPDT			
	R	E	NO contact		NC contact	
Coil tolerance*	R	E	R	E	R	E
6 sec	800 A	650 A	800 A	650 A	400 A	320 A
1 min	280 A	220 A	280 A	220 A	210 A	170 A
3 min	210 A	170 A	210 A	170 A	170 A	150 A
5 min	190 A	155 A	190 A	155 A	160 A	---
10 min	170 A	---	170 A	---	150 A	---

Above current ratings refer to wire cross-section 35 mm<sup>2</sup>

\* Coil voltage tolerance  
**R:** -30 % ... +10 % U<sub>s</sub>  
**E:** -30 % ... +25 % U<sub>s</sub>



**Note:**

- The thermal current rating for continuous duty is dependent on the upper limiting temperature of the contact elements which must not exceed 150°C. Wire gauge, ambient temperature, duty and operating cycles, contamination of contacts and contact wear are all factors that influence the surface temperature rise of the contact studs. All the above current ratings should, therefore, be considered as a guide only.
- The way you mount the contactor has no less an impact on the rise of temperature and the insulation of the switching device. So please observe the clearance between live and earthed parts and comply with the safety regulations of the applicable standards. No liability will be accepted by Schaltbau in any circumstances for indirect damage resulting from clearances not being observed, devices not mounted properly, or products tampered with in any way.

• **Possible mounting orientations**

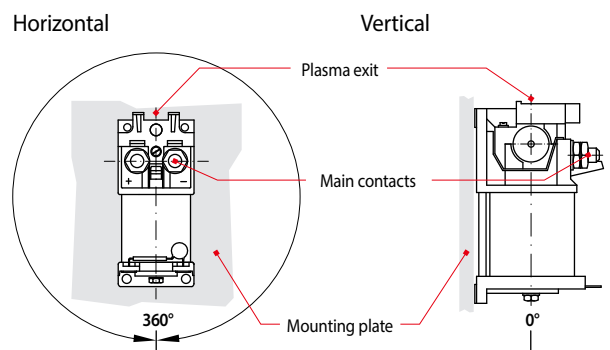

**Mounting positions:**

- Horizontal: contact studs must point upwards or
- Vertical: plasma exits must point upwards

**C163 SPST-NO or SPDT contactor [only for spare parts requirements / no new projects]**

C165 series

• **Device outline: C165 series SPST-NO contactor**

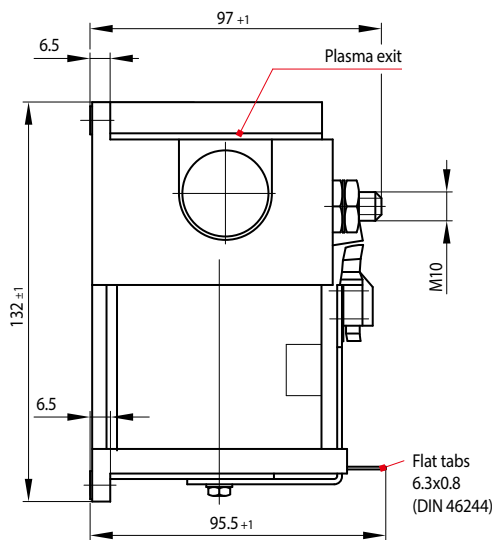
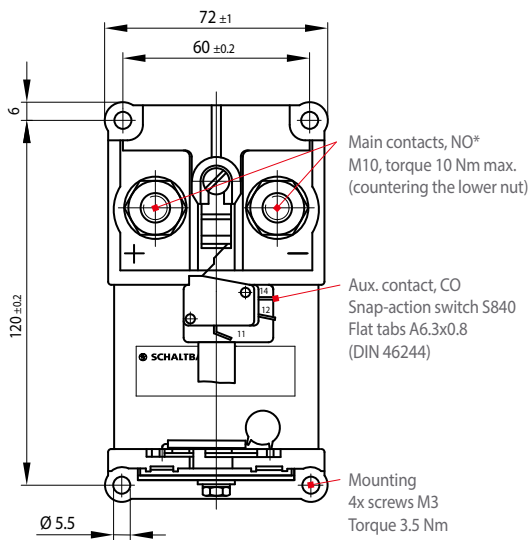

• **Circuit diagram**

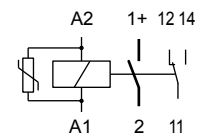

**Note:**  
Fitted with varistor and auxiliary contact, see ordering code on page 3.

\* SPST-NO contactor:  
NO for load switching,  
with magnetic blowout

• **Device outline: C165 series SPDT contactor**

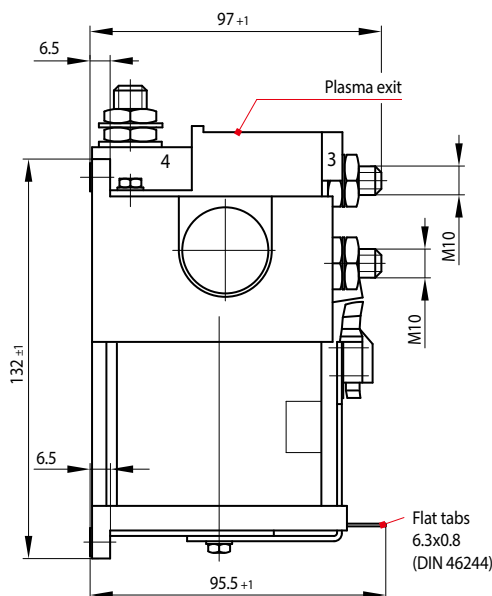
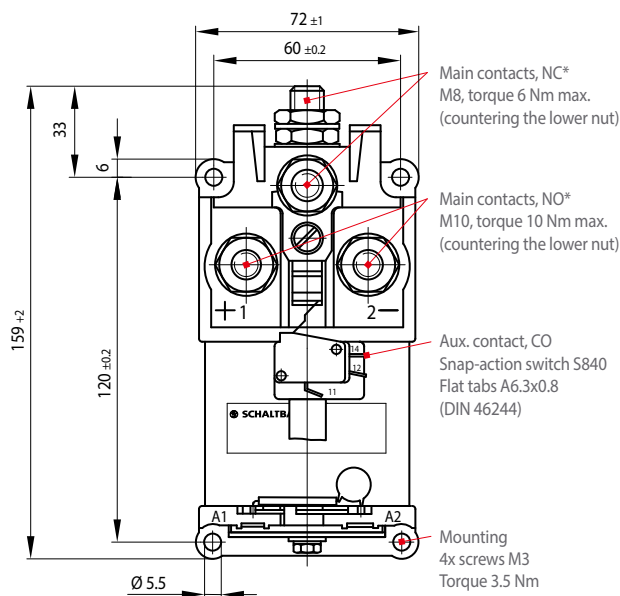

• **Circuit diagram**

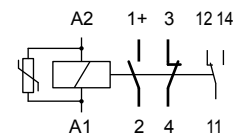

**Note:**  
Fitted with varistor and auxiliary contact, see ordering code on page 3.

\* SPDT contactors:  
NO for load switching, with  
magnetic blowout;  
NC for non load switching  
without magnetic  
blowout.

**HK-C165 Auxiliary contact [only for spare parts requirements / no new projects]**

C165 series

• **Auxiliary contact assembly HK-C165**



• **Mounting:**

C165 series contactors can be retrofitted with an auxiliary contact. Loosen the M5 hex screw a little that connects the yoke to the magnet core. Slide slotted mounting bracket of auxiliary contact assembly under screw head. Push yoke against housing and retighten screw.

**Characteristic curves Contact performance**

**Dimensioning, mounting instructions**

C165 series

• **Continuously rated, normally open contact**

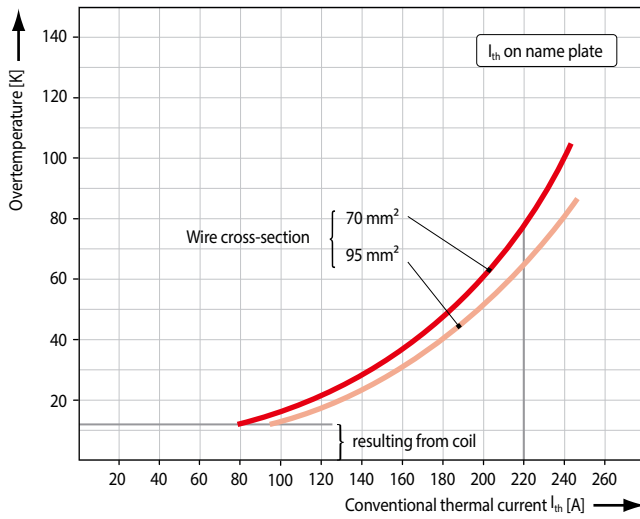

• **Continuously rated, normally closed contact**

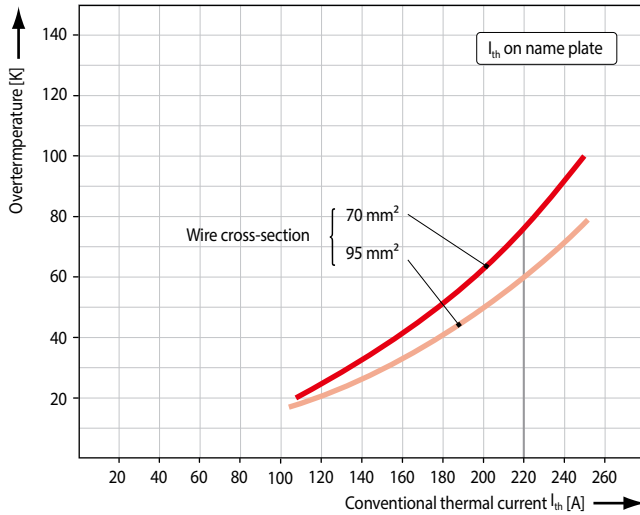

• **Max. breaking capacity DC of NO contact for coil tolerance R and E**

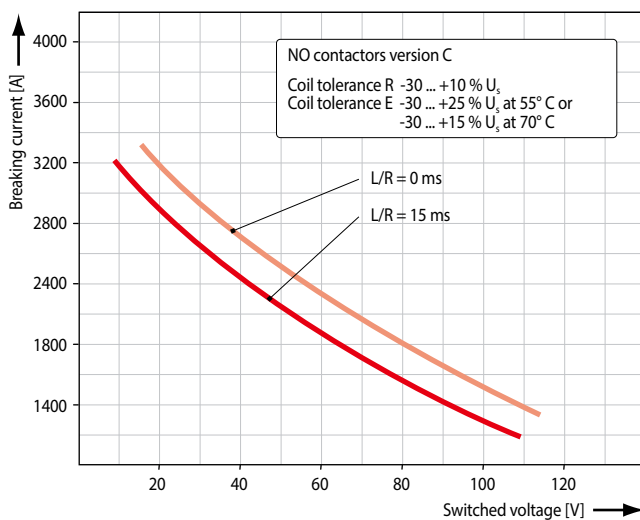

**Note:**

- The maximum breaking capacity is the value of prospective current at a stated DC voltage which can be ruptured by the contactor where the ensuing arc upon contact separation is still being quenched. For actual operation the current rating of the contactor should, therefore, be limited to 20 % ... 60 % of its maximum breaking capacity.
- Please note that for double throw contactors, in addition to the foregoing limitations, the switch off load of the normally open contact must be further reduced by 30 % to 50 %.

• **Guide to permissible current rating**

Short-time duty	SPST-NO		SPDT			
			NO contact		NC contact	
Coil tolerance*	R	E	R	E	R	E
6 sec	1,500 A	1,200 A	1,500 A	1,200 A	650 A	520 A
1 min	500 A	400 A	500 A	400 A	320 A	250 A
3 min	400 A	320 A	400 A	320 A	270 A	210 A
5 min	350 A	280 A	350 A	280 A	250 A	---
10 min	300 A	240 A	300 A	240 A	230 A	---

Above current ratings refer to wire cross-section 70 mm<sup>2</sup>

\* Coil voltage tolerance

R: -30 % ... +10 % U<sub>s</sub>

E: -30 % ... +25 % U<sub>s</sub> at 55 °C / -30 % ... +15 % U<sub>s</sub> at 70 °C



**Note:**

- The thermal current rating for continuous duty is dependent on the upper limiting temperature of the contact elements which must not exceed 150°C. Wire gauge, ambient temperature, duty and operating cycles, contamination of contacts and contact wear are all factors that influence the surface temperature rise of the contact studs. All the above current ratings should, therefore, be considered as a guide only.
- The way you mount the contactor has no less an impact on the rise of temperature and the insulation of the switching device. So please observe the clearance between live or earthed parts and comply with the safety regulations of the applicable standards. No liability will be accepted by Schaltbau in any circumstances for indirect damage resulting from clearances not being observed, devices not mounted properly, or products tampered with in any way.

• **Possible mounting orientations**

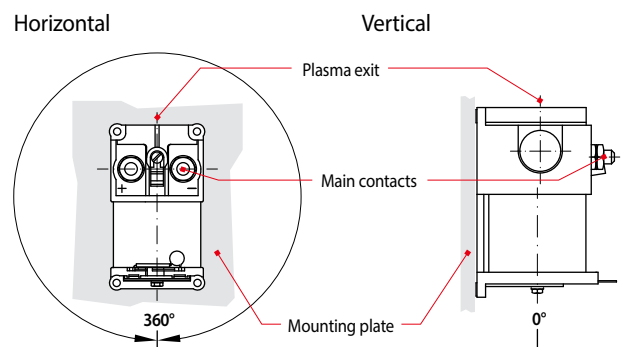

**Mounting positions:**

- Horizontal: contact studs must point upwards or
- Vertical: plasma exits must point upwards

Notes

A large area of the page is filled with horizontal dotted lines, providing space for handwritten notes.

**Notes**

A series of horizontal dotted lines for writing notes, organized into two columns.



# Schaltbau GmbH

For detailed information on our products and services visit our website – or give us a call!

Phone +49 89 9 30 05-0  
Internet [www.schaltbau.de](http://www.schaltbau.de)  
e-mail [contact@schaltbau.de](mailto:contact@schaltbau.de)

Find your worldwide contact person. We are here for you, personally!



with compliments:



The production facilities of Schaltbau GmbH have been IRIS certified since 2008.



Certified to DIN EN ISO 14001 since 2002. For the most recent certificate visit our website.



Certified to DIN EN ISO 9001 since 1994. For the most recent certificate visit our website.

## Electrical Components and Systems for Railway Engineering and Industrial Applications

### Connectors

- Connectors manufactured to industry standards
- Connectors to suit the special requirements of communications engineering (MIL connectors)
- Charging connectors for battery-powered machines and systems
- Connectors for railway engineering, including UIC connectors
- Special connectors to suit customer requirements

### Snap-action switches

- Snap-action switches with positive opening operation
- Snap-action switches with self-cleaning contacts
- Snap-action switch made of robust polyetherimide (PEI)
- Snap-action switch with two galvanically isolated contact bridges
- Special switches to suit customer requirements

### Contactors Emergency disconnect switches

- Single and multi-pole DC contactors
- High-voltage AC/DC contactors
- Contactors for battery powered vehicles and power supplies
- Contactors for railway applications
- Terminal bolts and fuse holders
- DC emergency disconnect switches
- Special contactors to suit customer requirements

### Electrics for rolling stock

- Equipment for driver's cab
- Equipment for passenger use
- High-voltage switchgear
- High-voltage heaters
- High-voltage roof equipment
- Equipment for electric brakes
- Design and engineering of train electrics to customer requirements