

3

Contactors

C360 series

1 pole
AC and bi-directional DC
NO contactors for
150 A, 300 A and 500 A
for railway applications

Catalogue C360.en



More information
schaltbau.com

C360 – 1 pole AC and bi-directional DC NO contactors for railway applications







Compact single-pole NO contactors for AC and DC up to 1,500 volt rated insulation voltage. Making current up to 2,500 amps; conventional thermal current up to 500 amps; short-time current up to 3,000 amps.

The bi-directional DC contactors switch high powers in a small space. With a making capacity of up to 2,500 amps, the compact switchgear is suitable for applications with high inrush current or high capacities. All versions can continuously conduct up to 500 amps. In the event of a short circuit, 3,000 amps, can even flow for one second without the contacts welding.

The full bi-directionality is important for many applications in railway vehicles. Many design variants are also available, matched to a wide range of applications, e.g. as the main contactor in traction and auxiliary converters of battery and hybrid vehicles or as a disconnecter in battery circuits with high currents.

Features





C360 series

-  **Compact dimensions – high rated insulation voltage U_i up to 1,500 volts**
The C360 – small dimensions, big performance! Nevertheless, all the air gaps in the contact area have been generously dimensioned. The rated insulation voltage is 1,500 volts. The arc chamber of the C360 is made of plastic. This is efficient and saves weight.
-  **High short-time withstand current rating I_{cw} of up to 3,000 amps**
The C360 can carry a current of up to 3,000 amps for one second without the contacts welding. This is enough time for the short circuit fuse to trip. The short-time withstand current rating is based on high contact forces and optimised silver contacts.
-  **High making capacity I_{cm} of up to 2,500 amps**
The C360 can switch on a current of up to 2,500 amps (monostable design in a horizontal installation position; $L/R = 0$ ms). A PWM controller regulates the coil current and ensures low-bounce switch-on as well as a low holding power. High contact forces and optimised silver contacts both contribute to the excellent making capacity
-  **Full bi-directionality – reliable disconnection of high powers**
All versions of the C360 can reliably disconnect high currents and voltages, irrespective of the current direction. These properties are achieved in the A and K versions through the special arrangement of blowout magnets and arcing chambers, high contact forces and generously dimensioned clearances in the contact area.
-  **High thermal continuous current I_{th} of up to 500 amps**
All versions of the C360 can continuously carry up to 500 amps. (Cross-section of the connections: 185 mm², maximum ambient temperature: 85° C; terminal heating: +65 Kelvin). The value is achieved through very high contact forces.
-  **Auxiliary switch with mirror contact function**
C360 contactors are equipped with auxiliary switches with mirror contact function in accordance with EN 60947-4-1, annex F. Mirror contacts are required for the feedback circuits in safety controls. Mirror contacts ensure that the NC contact of the auxiliary contact is not closed at the same time as the NO main contact.

Standards

C360 series

Contactors meet requirements for railway applications to:

-  **IEC 60077-1:2002**
Railway applications – Electric equipment for rolling stock – Part 1: General service conditions and general rules
-  **IEC 61373:2010**
Railway applications – Rolling stock equipment – Shock and vibration tests
-  **IEC 60077-2:2002**
Railway applications – Electric equipment for rolling stock – Part 2: Electrotechnical components; General rules
-  **IEC 62497-1:2010**
Railway applications – Insulation coordination – Part 1: Basic requirements – Clearances and creepage distances for all electrical and electronic equipment

Reliable, robust and economical C360 series

Contactors of the C360 series are designed for continuous currents of 150 amps, 300 amps and 500 amps. The switchgear has both high making and breaking capacities, and a high short-time withstand current. This ensures high operational safety.

An integrated electronic coil control ensures a constant and reliable switching behaviour independent of the ambient temperature. In addition, the energy consumption and associated heat development of the monostable design is noticeably reduced when switched on. Inherent to its design, the bistable version consumes no power in either end positions.

Dependent on the application, high requirements can be placed on electromechanical components. The new DC contactors are highly resistant to shock and vibration loads and meet the high requirements of ISO 16750.

Ordering key C360 series

Example: **C360A/500 24I-V1**

Series, contact configuration

C360 1 pole NO contactor, AC and DC bi-directional

Version

K 1,500 V DC, large arc chamber
 A 1,000 V DC, small arc chamber
 S 60 V DC, without arc chamber

Conv. thermal current

150 $I_{th} = 150 A$
 300 $I_{th} = 300 A$
 500 $I_{th} = 500 A$

Coil voltage

	Monostable	Bistable
24	$U_s = 24 V DC^{*1}$	$U_s = 24 V DC^{*3}$
110	$U_s = 72 \dots 110 V DC^{*2}$	$U_s = 110 V DC^{*3}$

*1 Operating range 9.5 ... 36 V DC
 *2 Operating range 50.4 ... 137.5 V DC
 *3 Coil tolerance -30 % ... +25 %

Accessories

C310-TP Deflection shield, C360A/... only

Auxiliary switches, number / type

--- V0
 S880 W1R6 k / 1x V1
 S880 W1R6 k / 2x V2

Coil design

Monostable with integrated PWM module I
 Bistable without PWM module B

Note:
 Presented in this catalogue are only stock items which can be supplied in short delivery time. For some variants minimum quantities apply. Please do not hesitate to ask for the conditions.
Special variants:
 If you need a special variant of the contactor, please do not hesitate to contact us. Maybe the type of contactor you are looking for is among our many special designs. If not, we can also supply customized designs. In this case, however, minimum order quantities apply.

Application C360 series

Thanks to many years of experience and competence developing electromechanical switchgear and the mastering DC arcs, Schaltbau has developed an innovative solution with new DC contactors that significantly simplifies applications with DC switching technology. The C360 series is therefore suitable for universal use in railway networks as a DC

contactor for traction and auxiliary converters. As the switchgear also reliably masters switching in both current directions, it is ideally suited for applications with energy recovery. Typical examples are traction batteries that are charged and discharged during operation.

Traction contactors for battery or hybrid vehicles
 Main contactors in combination with a precharging contactor in traction converter of locomotives, railcars and trams

Contactors for auxiliary converter
 Main contactors in combination with a precharging contactor in auxiliary converter of locomotives, railcars and trams

- Disconnecting contactors in battery circuits**
- Disconnecting contactors for battery-powered functions in locomotives and multiple units
 - Contactors for battery-powered functions in passenger coaches
 - Deep discharge protection for batteries in emergency power supplies

C360 – Version «K» Circuit diagram, dimension diagram

C360 series



**C360K/ – 1 pole NO contactor
AC or bi-directional DC**

- Large arc chamber for significantly higher breaking capacity
- Rated insulation voltage U_i up to 1,500 V
- Rated short-circuit making capacity I_{cm} up to 2,500 A
- Conventional free air thermal current I_{th} up to 500 A
- Rated short-time withstand current I_{cw} up to 3,000 A

Arc chamber main contact system
Highly efficient plastic arc chamber with permanent magnetic blowing

Aux. switch
S880, SPDT, flat tabs 2.8 x 0.5 mm

Coil terminal
Flat tabs 6.3 x 0.8 mm

Main contact terminals

Series	Material	
C360K/150 ...	Copper	⊕
C360K/300 ...	Copper	
C360K/500 ...	Copper, silver plated	
Series	Thickness	
C360K/150 ...	3 mm	⊕
C360K/300 ...	5 mm	
C360K/500 ...	5 mm	
Series	Diameter	
C360K/150 ...	∅ 9 mm	⊕
C360K/300 ...	∅ 11 mm	
C360K/500 ...	∅ 11 mm	

Circuit diagram

	Monostable *	Bistable **
C360K/... Main contacts 1x NO Number of auxiliary switches none		
C360K/... Main contacts 1x NO Number of auxiliary switches*** 1x SPDT S880 W1R6 k		
C360K/... Main contacts 1x NO Number of auxiliary switches*** 2x SPDT S880 W1R6 k		



- * Coil suppression integrated, additional circuit is not allowed!
- ** Switching by reversing the polarity, voltage pulse 0.5 sec max.
- *** Auxiliary switches with mirror contact function according to EN 60947-4-1, annex F

Dimension diagram C360K/...

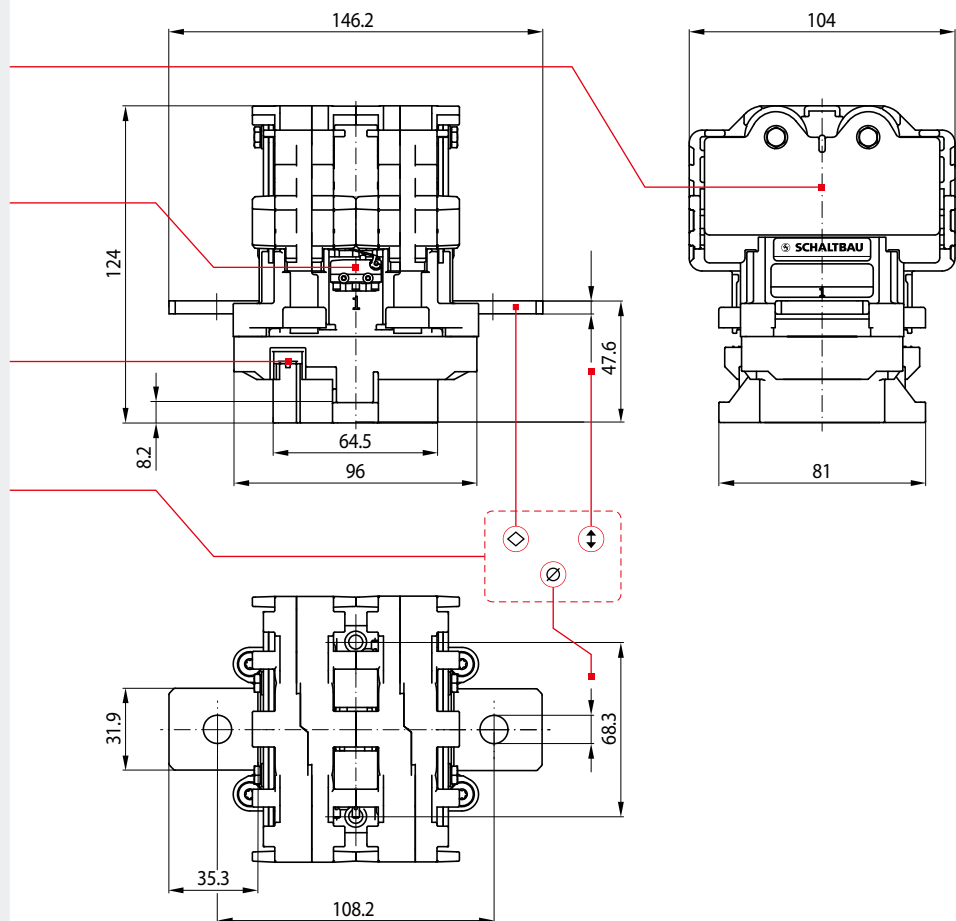

Specifications Version «K» for $U_r = 1,500$ V DC

C360 series

Series		C360K/150	C360K/300	C360K/500
Type of voltage		DC, bi-directional / AC, $f \leq 60$ Hz, 1,000 V max.		
Main contacts, configuration		1x NO		
General electrical ratings of main circuit				
Rated operational voltage U_r	max.	1,000 V @ PD3 / 1,500 V @ PD2		
Rated insulation voltage U_{Nm}		1,000 V @ PD3 / 1,500 V @ PD2		
Rated impulse withstand voltage U_{Ni}		10 kV		
Pollution degree / Overvoltage category		PD2, PD3: see U_{Nm} / OV3		
Conventional free air thermal current I_{th}	$T_a = 40^\circ$ C $T_a = 70^\circ$ C	150 A * 150 A	300 A * 300 A	500 A 400 A
Power dissipation per pole	I_{th} @ 40° C, typ.	3.5 W	11 W	30 W
Pole impedance	typ.	150 $\mu\Omega$	120 $\mu\Omega$	120 $\mu\Omega$
Geräteklasse	IEC 60077-2	B		
Rated short-circuit breaking capacity		150 A		
DC	I_r @ $L/R = 1$ ms / $U_r = 900$ V	420 A		
AC	I_r @ $\cos\phi = 0.8$ / $U_r = 900$ V			
Rated short-time withstand current I_{CW}	$t = 0,1$ s $t = 1$ s	4,000 A 3,000 A		
Critical current range		none	none	none
Additional electrical ratings of main circuit				
Conventional free air thermal current I_{th}	$T_a = 85^\circ$ C (cross section) Terminal heating	200 A (50 mm ²) 45 K	350 A (120 mm ²) 45 K	500 A (185 mm ²) 65 K
Short circuit protection device for contactors (w/o thermal overload relay)	$I_{prosp} = 10$ kA DC, $L/R = 5$ ms, welding proof Fuse: SIBA SQB-DC 2 (aR Type)	200 A	315 A	2x 250 A (parallel)
Rated short-circuit making capacity I_{cm} ($L/R = 0$ ms)	For mono- or bistable drive (depending on mounting position)	monostable: horizontal: 2,500 A, vertical: 2,000 A bistable: horizontal: 750 A, vertical: 750 A		
Breaking capacity	$L_{max} = 0.25$ mH, other values on request			
Single contact	$U_r = 1.500$ V / $I_r = 300$ A $U_r = 1.000$ V / $I_r = 500$ A $U_r = 900$ V / $I_r = 700$ A $U_r = 750$ V / $I_r = 1.000$ A $U_r = 500$ V / $I_r = 1.500$ A	10 operations 20 operations 25 operations 10 operations 15 operations		
Double contact circuit	$U_r = 1.500$ V / $I_r = 1.000$ A $U_r = 1.000$ V / $I_r = 1.700$ A	10 operations 15 operations		
Electrical endurance		6,000 operations @ DC ($L/R = 1$ ms), AC ($\cos\phi = 0.8$): 750 V / 60 A		
Main contacts				
Contact material		AgSnO ₂	AgSnO ₂	AgSnO ₂
Terminals		M8	M10	M10
Torque		4.8 ... 6 Nm	8 ... 10 Nm	8 ... 10 Nm
Auxiliary contacts				
Number, configuration / Contact material		2x S880 W1R6 k max. / Silver		
Making / Breaking capacity S880		AC-15: 230 V AC / 1.0 A DC-13: 60 V DC / 0.5 A		
Minimum voltage / Current		5 V / 5 mA		
Terminals		Flat quick connect 2.8 x 0.5 mm		
Magnetic drive – monostable				
Rated control supply voltage U_s		24 / 72 ... 110 V DC		
Pollution degree / Overvoltage category		PD3 / OV2		
Coil tolerance		-30 % ... +25 % U_s		
Coil power dissipation, max. ($T_a = 20^\circ$ C / U_s)		50 W / 2.6 W		
Pull-in power (0.2 s) / Holding power				
Frequency of operation (operations per hour, no load)	$T_a = 20^\circ$ C / 70° C	3,600 h ⁻¹ / 1,800 h ⁻¹		
Pull-in time ($T_a = 20^\circ$ C / U_s) / Drop-off time ($T_a = 20^\circ$ C / U_s)	typ.	33 ms / 25 ms		
Coil suppression (integrated) / Coil terminal		Suppressor diode / Flat tap 6.3 x 0.8 mm		
Magnetic drive – bistable				
Rated control supply voltage U_s		24 / 110 V DC @ ON time 0.1 ... 0.5 s max.		
Pollution degree / Overvoltage category		PD3 / OV2		
Coil tolerance		-30 % ... +25 % U_s		
Coil power dissipation, max. ($T_a = 20^\circ$ C / U_s)		35 W		
Frequency of operation (operations per hour, no load)	$T_a = 20^\circ$ C / 70° C	1,800 h ⁻¹ / 1,800 h ⁻¹		
Pull-in time ($T_a = 20^\circ$ C / U_s) / Drop-off time ($T_a = 20^\circ$ C / U_s)	typ.	20 ms / 13 ms		
Coil suppression (integrated) / Coil terminal		Suppressor diode / Flat tap 6.3 x 0.8 mm		
Mounting position		vertical / horizontal (not upside-down, see page 11)		
Degree of protection	IEC 60529	IP00		
Mechanical endurance	monostable / bistable	2,000,000 operations / 100,000 operations (Replace auxiliary switch after 1,000,000 switching cycles)		
Shock / Vibration	IEC 61373 / ISO 16750-3	Category 1, Class B / Class C		
Temperatures	Operating temperature / Storage temperature Altitude / Humidity (EN 50125-1)	-40 °C ... +85 °C / -40 °C ... +85 °C < 4,500 m @ $U_i = 1,000$ V, < 3,500 m @ $U_i = 1,500$ V / < 75 % on an annual average		
Weight		1.24 kg	1.31 kg	1.35 kg

C360 – Version «A» Circuit diagram, dimension diagram

C360 series



C360A/ – 1 pole NO contactor
AC or bi-directional DC

- Rated insulation voltage U_i up to 1,500 V, version with small arc chamber
- Rated short-circuit making capacity I_{cm} up to 2,500 A
- Conventional free air thermal current I_{th} up to 500 A
- Rated short-time withstand current I_{cw} up to 3,000 A

Circuit diagram

	Monostable *	Bistable **
C360A/... Main contacts 1x NO Number of auxiliary switches none		
C360A/... Main contacts 1x NO Number of auxiliary switches*** 1x SPDT S880 W1R6 k		
C360A/... Main contacts 1x NO Number of auxiliary switches*** 2x SPDT S880 W1R6 k		



- * Coil suppression integrated, additional circuit is not allowed!
- ** Switching by reversing the polarity, voltage pulse 0.5 sec max.
- *** Auxiliary switches with mirror contact function according to EN 60947-4-1, annex F

Dimension diagram C360A/...

- Arc chamber cover**
Reduces the distance to live, metallic or grounded parts
- Arc chamber main contact system**
Highly efficient plastic arc chamber with permanent magnetic blowing
- Aux. switch**
S880, SPDT, flat tabs 2.8 x 0.5 mm
- Coil terminal**
Flat tabs 6.3 x 0.8 mm

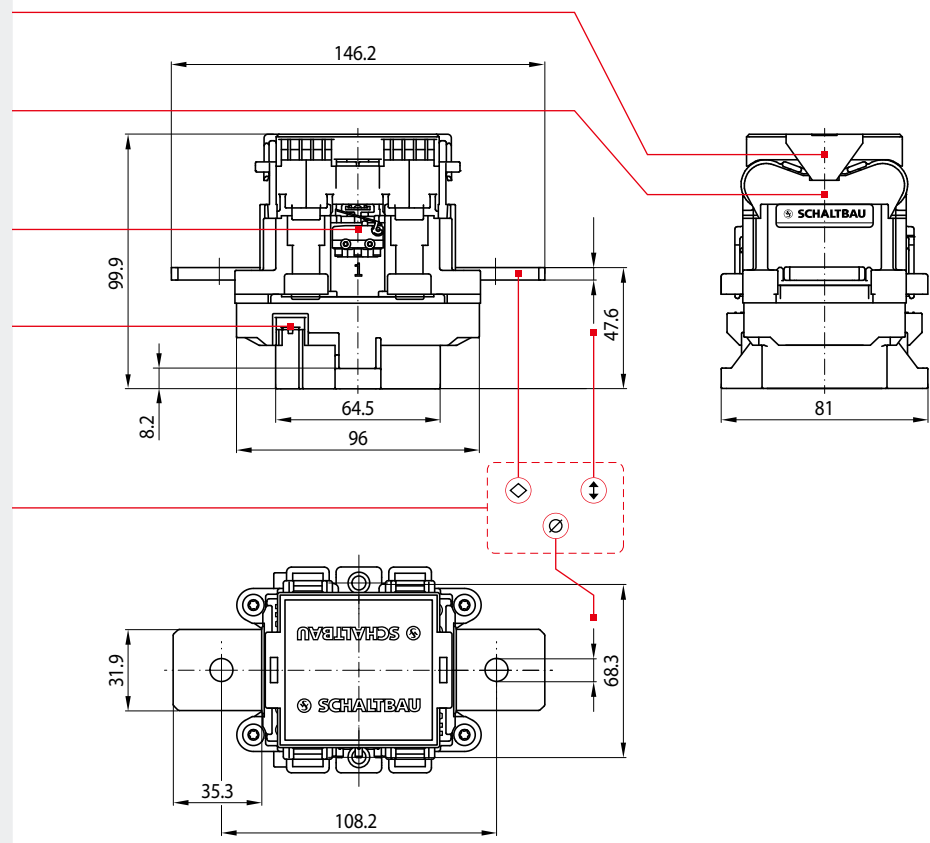

Main contact terminals

Series	Material	Symbol
C360A/150 ...	Copper	◇
C360A/300 ...	Copper	◇
C360A/500 ...	Copper, silver plated	◇
Series	Thickness	Symbol
C360A/150 ...	3 mm	⊕
C360A/300 ...	5 mm	⊕
C360A/500 ...	5 mm	⊕
Series	Diameter	Symbol
C360A/150 ...	∅ 9 mm	⊙
C360A/300 ...	∅ 11 mm	⊙
C360A/500 ...	∅ 11 mm	⊙

Specifications Version «A» for $U_r = 1,500$ V DC

C360 series

Series		C360A/150	C360A/300	C360A/500
Type of voltage		DC, bi-directional / AC, $f \leq 60$ Hz, 1,000 V max.		
Main contacts, configuration		1x NO		
General electrical ratings of main circuit				
Rated operational voltage U_r	max.	1,000 V @ PD3 / 1,500 V @ PD2		
Rated insulation voltage U_{Nm}		1,000 V @ PD3 / 1,500 V @ PD2		
Rated impulse withstand voltage U_{Ni}		10 kV		
Pollution degree / Overvoltage category		PD2, PD3: see U_{Nm} / OV3		
Conventional free air thermal current I_{th}	$T_a = 40^\circ$ C $T_a = 70^\circ$ C	150 A * 150 A	300 A * 300 A	500 A 400 A
Power dissipation per pole	I_{th} @ 40 °C, typ.	3.5 W	11 W	30 W
Pole impedance	typ.	150 $\mu\Omega$	120 $\mu\Omega$	120 $\mu\Omega$
Gerätekatgorie	IEC 60077-2	B		
Rated short-circuit breaking capacity				
DC	I_r @ L/R = 1 ms / $U_r = 900$ V	150 A		
AC	I_r @ $\cos\phi = 0.8$ / $U_r = 900$ V	420 A		
Rated short-time withstand current I_{CW}	$t = 0,1$ s $t = 1$ s	4,000 A 3,000 A		
Critical current range		none	none	none
Additional electrical ratings of main circuit				
Conventional free air thermal current I_{th}	$T_a = 85^\circ$ C (cross section) Terminal heating	200 A (50 mm ²) 45 K	350 A (120 mm ²) 45 K	500 A (185 mm ²) 65 K
Short circuit protection device for contactors (w/o thermal overload relay)	$I_{prosp} = 10$ kA DC, L/R = 5 ms, welding proof Fuse: SIBA SQB-DC 2 (aR Type)	200 A	315 A	2x 250 A (parallel)
Rated short-circuit making capacity I_{cm} (L/R = 0 ms)	For mono- or bistable drive (depending on mounting position)	monostable: horizontal: 2,500 A, vertical: 2,000 A bistable: horizontal: 750 A, vertical: 750 A		
Breaking capacity	$L_{max} = 0.25$ mH, other values on request			
Single contact	$U_r = 1,500$ V / $I_r = 50$ A $U_r = 900$ V / $I_r = 400$ A $U_r = 750$ V / $I_r = 500$ A $U_r = 500$ V / $I_r = 800$ A	60 operations 60 operations 60 operations 60 operations		
Double contact circuit	$U_r = 1,500$ V / $I_r = 500$ A $U_r = 1,000$ V / $I_r = 800$ A	60 operations 60 operations		
Electrical endurance		6,000 operations @ DC (L/R = 1 ms), AC ($\cos\phi = 0.8$): 750 V / 60 A		
Main contacts				
Contact material		AgSnO ₂	AgSnO ₂	AgSnO ₂
Terminals		M8	M10	M10
Torque		4.8 ... 6 Nm	8 ... 10 Nm	8 ... 10 Nm
Auxiliary contacts				
Number, configuration / Contact material		2x S880 W1R6 k max. / Silver		
Making / Breaking capacity S880		AC-15: 230 V AC / 1.0 A DC-13: 60 V DC / 0.5 A		
Minimum voltage / Current		5 V / 5 mA		
Terminals		Flat quick connect 2.8 x 0.5 mm		
Magnetic drive – monostable				
Rated control supply voltage U_s		24 / 72 ... 110 V DC		
Pollution degree / Overvoltage category		PD3 / OV2		
Coil tolerance		-30 % ... +25 % U_s		
Coil power dissipation, max. ($T_a = 20^\circ$ C / U_s)		50 W / 2.6 W		
Pull-in power (0.2 s) / Holding power				
Frequency of operation (operations per hour, no load)	$T_a = 20^\circ$ C / 70 °C	3,600 h ⁻¹ / 1,800 h ⁻¹		
Pull-in time ($T_a = 20^\circ$ C / U_s) / Drop-off time ($T_a = 20^\circ$ C / U_s)	typ.	33 ms / 25 ms		
Coil suppression (integrated) / Coil terminal		Suppressor diode / Flat tap 6.3 x 0.8 mm		
Magnetic drive – bistable				
Rated control supply voltage U_s		24 / 110 V DC @ ON time 0.1 ... 0.5 s max.		
Pollution degree / Overvoltage category		PD3 / OV2		
Coil tolerance		-30 % ... +25 % U_s		
Coil power dissipation, max. ($T_a = 20^\circ$ C / U_s)		35 W		
Frequency of operation (operations per hour, no load)	$T_a = 20^\circ$ C / 70 °C	1,800 h ⁻¹ / 1,800 h ⁻¹		
Pull-in time ($T_a = 20^\circ$ C / U_s) / Drop-off time ($T_a = 20^\circ$ C / U_s)	typ.	20 ms / 13 ms		
Coil suppression (integrated) / Coil terminal		Suppressor diode / Flat tap 6.3 x 0.8 mm		
Mounting position		vertical / horizontal (not upside-down, see page 11)		
Degree of protection	IEC 60529	IP00		
Mechanical endurance	monostable / bistable	2,000,000 operations / 100,000 operations (Replace auxiliary switch after 1,000,000 switching cycles)		
Shock / Vibration	IEC 61373 / ISO 16750-3	Category 1, Class B / Class C		
Temperatures	Operating temperature / Storage temperature Altitude / Humidity (EN 50125-1)	-40 °C ... +85 °C / -40 °C ... +85 °C < 4,500 m @ $U_i = 1,000$ V, < 3,500 m @ $U_i = 1,500$ V / < 75 % on an annual average		
Weight		0.83 kg	0.90 kg	0.95 kg

C360 – Version «S» Circuit diagram, dimension diagram

C360 series



**C360S/ – 1 pole NO contactor
AC or bi-directional DC**

- Rated insulation voltage U_i
up to 1,500 V, version without
arc chamber
- Rated short-circuit making capacity I_{cm}
up to 2,500 A
- Conventional free air thermal current I_{th}
up to 500 A
- Rated short-time withstand current I_{cw}
up to 3,000 A

Circuit diagram

	Monostable *	Bistable **
C360S/... Main contacts 1x NO Number of auxiliary switches none		
C360S/... Main contacts 1x NO Number of auxiliary switches*** 1x SPDT S880 W1R6 k		
C360S/... Main contacts 1x NO Number of auxiliary switches*** 2x SPDT S880 W1R6 k		



- * Coil suppression integrated,
additional circuit is not allowed!
- ** Switching by reversing the polarity,
voltage pulse 0.5 sec max.
- *** Auxiliary switches with mirror contact function
according to EN 60947-4-1, annex F

Dimension diagram C360S/...

Switching chamber
Main contact system w/o arc chamber

Aux. switch
S880, SPDT, flat tabs 2.8 x 0.5 mm

Coil terminal
Flat tabs 6.3 x 0.8 mm

Main contact terminals

Series	Material	
C360S/150 ...	Copper	⊕
C360S/300 ...	Copper	
C360S/500 ...	Copper, silver plated	
Series	Thickness	
C360S/150 ...	3 mm	⊕
C360S/300 ...	5 mm	
C360S/500 ...	5 mm	
Series	Diameter	
C360S/150 ...	ø 9 mm	⊗
C360S/300 ...	ø 11 mm	
C360S/500 ...	ø 11 mm	

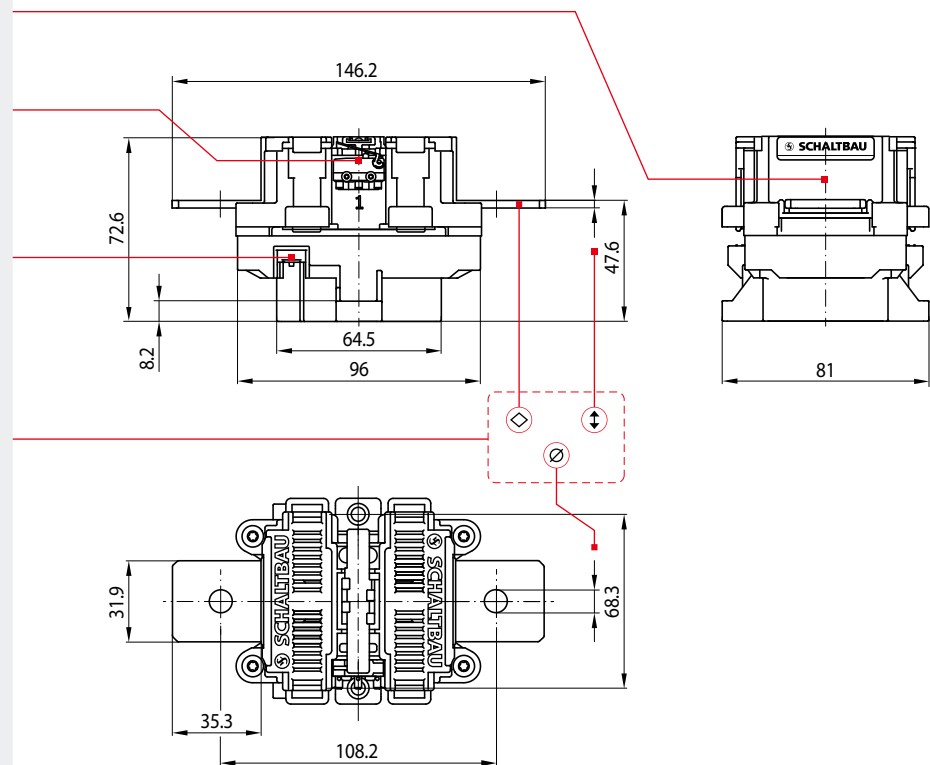

Specifications Version «S» for $U_r = 60$ V DC

C360 series

Series		C360S/150	C360S/300	C360S/500
Type of voltage		DC, bi-directional / AC, $f \leq 60$ Hz, 1,000 V max.		
Main contacts, configuration		1x NO		
General electrical ratings of main circuit				
Rated operational voltage U_r	max.	60 V		
Rated insulation voltage U_{Nm}		1,000 V @ PD3 / 1,500 V @ PD2		
Rated impulse withstand voltage U_{Ni}		10 kV		
Pollution degree / Overvoltage category		PD2, PD3: see U_{Nm} / OV3		
Conventional free air thermal current I_{th}	$T_a = 40^\circ\text{C}$ $T_a = 70^\circ\text{C}$	150 A * 150 A	300 A * 300 A	500 A 400 A
Power dissipation per pole	I_{th} @ 40°C , typ.	3.5 W	11 W	30 W
Pole impedance	typ.	150 $\mu\Omega$	120 $\mu\Omega$	120 $\mu\Omega$
Geräteklasse	IEC 60077-2	B		
Rated short-time withstand current I_{Cw}	$t = 0,1$ s $t = 1$ s		4,000 A 3,000 A	
Critical current range		none	none	none
Additional electrical ratings of main circuit				
Conventional free air thermal current I_{th}	$T_a = 85^\circ\text{C}$ (cross section) Terminal heating	200 A (50 mm ²) 45 K	350 A (120 mm ²) 45 K	500 A (185 mm ²) 65 K
Short circuit protection device for contactors (w/o thermal overload relay) $I_{prosp} = 10$ kA DC, L/R = 5 ms, welding proof Fuse: SIBA SQB-DC 2 (aR Type)		200 A	315 A	2x 250 A (parallel)
Rated short-circuit making capacity I_{cm} (L/R = 0 ms) For mono- or bistable drive (depending on mounting position)		monostable: horizontal: 2,500 A, vertical: 2,000 A bistable: horizontal: 750 A, vertical: 750 A		
Breaking capacity (L/R = 0.1 ms)	$U_r = 60$ V / $I_r = 2,000$ A $U_r = 96$ V / $I_r = 1,300$ A	60 operations 60 operations		
Electrical endurance		10,000 operations @ DC (L/R = 1 ms), AC ($\cos\phi = 0.8$): 48 V / 150 A	10,000 operations @ DC (L/R = 1 ms), AC ($\cos\phi = 0.8$): 48 V / 300 A	10,000 operations @ DC (L/R = 1 ms), AC ($\cos\phi = 0.8$): 48 V / 500 A
Main contacts				
Contact material		AgSnO ₂		
Terminals		M8 M10 M10		
Torque		4.8 ... 6 Nm 8 ... 10 Nm 8 ... 10 Nm		
Auxiliary contacts				
Number, configuration / Contact material		2x S880 W1R6 k max. / Silver		
Making / Breaking capacity S880		AC-15: 230 V AC / 1.0 A DC-13: 60 V DC / 0.5 A		
Minimum voltage / Current		5 V / 5 mA		
Terminals		Flat quick connect 2.8 x 0.5 mm		
Magnetic drive – monostable				
Rated control supply voltage U_s Pollution degree / Overvoltage category Coil tolerance		24 / 72 ... 110 V DC PD3 / OV2 -30 % ... +25 % U_s		
Coil power dissipation, max. ($T_a = 20^\circ\text{C}$ / U_s) Pull-in power (0.2 s) / Holding power		50 W / 2.6 W		
Frequency of operation (operations per hour, no load)	$T_a = 20^\circ\text{C}$ / 70°C	3,600 h ⁻¹ / 1,800 h ⁻¹		
Pull-in time ($T_a = 20^\circ\text{C}$ / U_s) / Drop-off time ($T_a = 20^\circ\text{C}$ / U_s) Coil suppression (integrated) / Coil terminal	typ.	33 ms / 25 ms Suppressor diode / Flat tap 6.3 x 0.8 mm		
Magnetic drive – bistable				
Rated control supply voltage U_s Pollution degree / Overvoltage category Coil tolerance		24 / 110 V DC @ ON time 0.1 ... 0.5 s max. PD3 / OV2 -30 % ... +25 % U_s		
Coil power dissipation, max. ($T_a = 20^\circ\text{C}$ / U_s)		35 W		
Frequency of operation (operations per hour, no load)	$T_a = 20^\circ\text{C}$ / 70°C	1,800 h ⁻¹ / 1,800 h ⁻¹		
Pull-in time ($T_a = 20^\circ\text{C}$ / U_s) / Drop-off time ($T_a = 20^\circ\text{C}$ / U_s) Coil suppression (integrated) / Coil terminal	typ.	20 ms / 13 ms Suppressor diode / Flat tap 6.3 x 0.8 mm		
Mounting position		vertical / horizontal (not upside-down, see page 11)		
Degree of protection	IEC 60529	IP00		
Mechanical endurance	monostable / bistable	2,000,000 operations / 100,000 operations (Replace auxiliary switch after 1,000,000 switching cycles)		
Shock / Vibration	IEC 61373 / ISO 16750-3	Category 1, Class B / Class C		
Temperatures	Operating temperature / Storage temperature Altitude / Humidity (EN 50125-1)	-40 °C ... +85 °C / -40 °C ... +85 °C < 4,500 m @ $U_i = 1,000$ V, < 3,500 m @ $U_i = 1,500$ V / < 75 % on an annual average		
Weight		0.55 kg	0.63 kg	0.65 kg

Minimum distances

C360 series

- C360K/... with large arc chamber

Minimum distance at max. load current

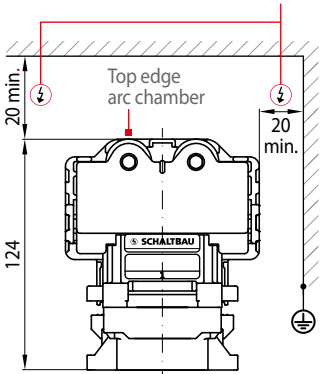

i For the C360K/150, C360K/300 and C360K/500 series there is a minimum distance of 20 mm to magnetically active, live or earthed parts.

- C360A/... with arc chamber cover

Minimum distance at max. load current,

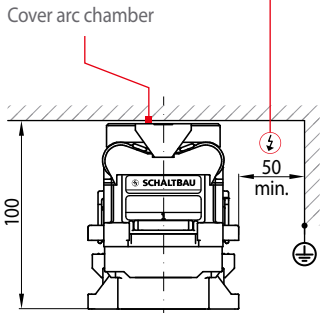

i The extinguishing chamber cover is part of the standard scope of delivery for the C360A/150, C360A/300 and C360A/500 series.

- C360A/... w/o arc chamber cover

Minimum distance at max. load current,

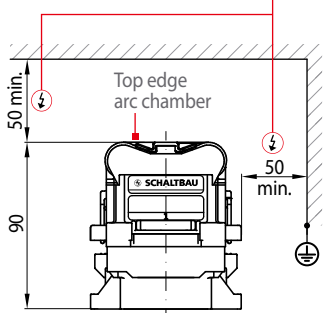

i It is permissible to use the C360A/150, C360A/300 and C360A/500 series without arc chamber cover, taking into account additional clearance dimensions.

- C360S/... w/o arc chamber

Cover main contact system

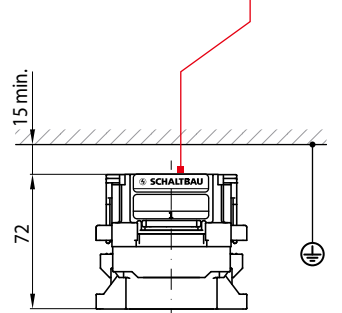

i For the C360S/150, C360S/300 and C360S/500 series there is a minimum distance of 15 mm to magnetically active, live or earthed parts.

- Insertable deflection shields:

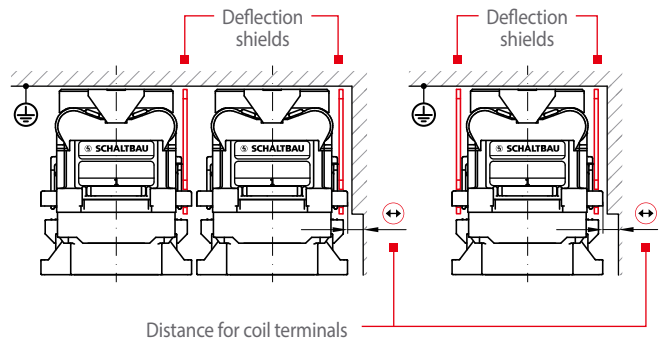

- Mounting holes

C360K/...

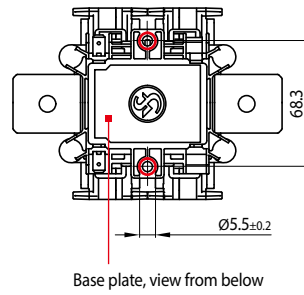

C360A/... and C360S/...

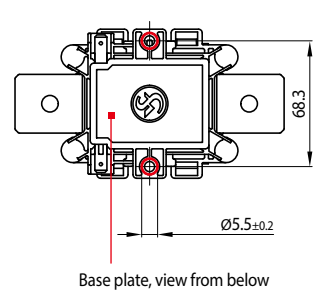

i C360A/... series only:
The use of insertable deflection shields reduces the minimum distance to 0 mm. Without deflection shields, the minimum distance of the contactors, depending on the arrangement, can increase to 100 mm.

Electrical endurance

C360 series

- Minimum distances ⚡ to live or earthed parts

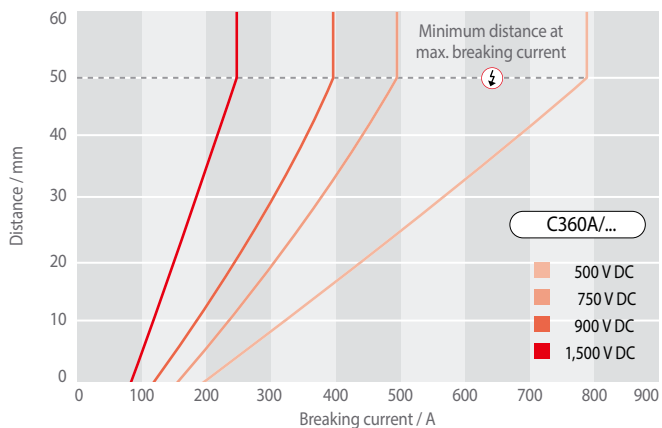

- Predicted electrical endurance as a function of the breaking current

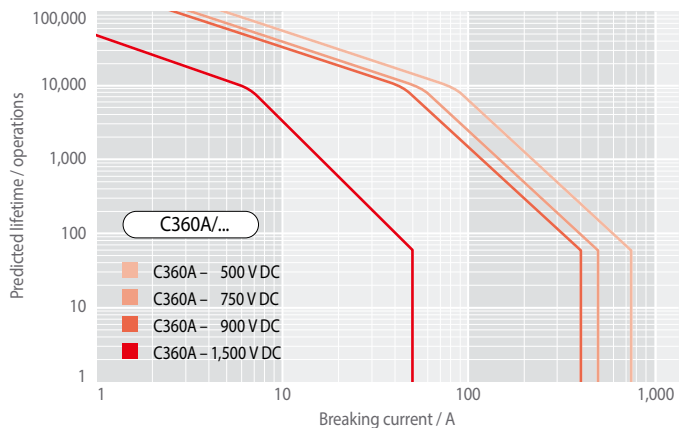

Mounting instructions

C360 series

• C360K/...

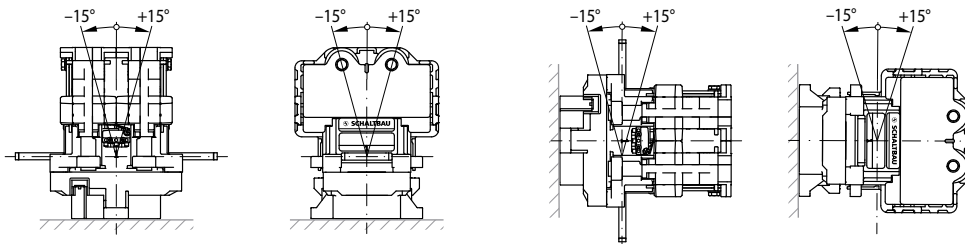

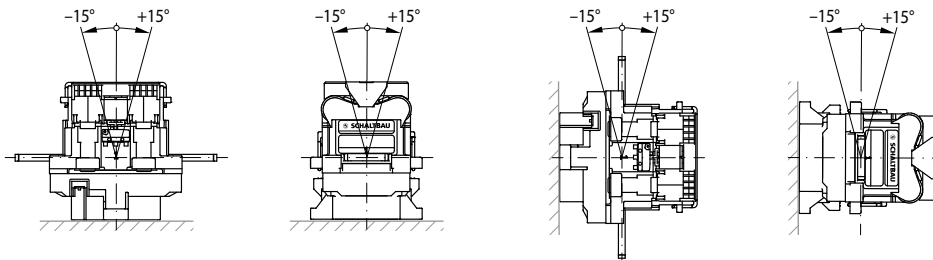

• C360A/...

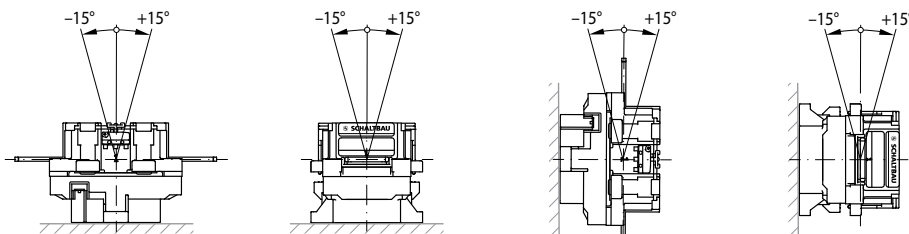

• C360S/...



 The contactors are mounted on a mounting plate with two M5 screws.

 The contactors can be mounted horizontally or vertically on a prepared mounting plate.

 Mounting positions hanging upside down are not allowed!

Horizontal assembly
«Table mounting»

Vertical assembly
«Wall mounting»

Maintenance and safety instructions

C360 series

Maintenance:

- C360 series contactors are basically maintenance free.
- Make regular in-depth visual inspections once or twice a year.



For detailed maintenance, safety and mounting instructions please refer to our operating manuals
➔ [C360-M.en!](#)

Safety instructions:

- The device must be used according to the intended purpose as specified in the technical documentation. You are obliged to observe all specifications depending on operating temperature, degree of pollution etc. that are relevant to your application.
- Without further safety measures the contactors are not suited for use in potentially explosive atmospheres.
- In case of malfunction of the device or uncertainties stop using it any longer and contact the manufacturer instantly.
- Tampering with the device can seriously affect the safety of people and equipment. This is not permitted and leads to an exclusion of liability and warranty.
- Coil suppression for reducing surges when the coil is switched off is optimally attuned to the contactors switching behaviour. The existing opening characteristic must not be negatively influenced by parallel connection with an external diode.
- Contactors running permanently may heat up. So make sure that the contactor has sufficiently cooled down before you start any inspection or maintenance work.

- When installing contactors with magnetic blowout make sure to do it in such a way that no magnetizable parts can be attracted by the permanent magnets that are also capable of destroying all data of swipe cards.
- In general, strong electromagnetic fields can be generated in the area around the contactors. These can influence other components in the area of the contactors.
- Improper handling of the contactor, e.g. when hitting the floor with some impact, can result in breakage, visible cracks and deformation.



Defective contactors or parts (e.g. arc chambers, auxiliary switches) must be replaced immediately!



For a detailed list of all safety instructions see here:
➔ schaltbau.info/safety3en!

Schaltbau GmbH

For detailed information on our products and services visit our website – or give us a call!

Phone +49 89 9 30 05-0
Internet www.schaltbau.de
e-mail contact@schaltbau.de

Find your worldwide contact person. We are here for you, personally!



with compliments:



The production facilities of Schaltbau GmbH have been IRIS certified since 2008.



Certified to DIN EN ISO 14001 since 2002. For the most recent certificate visit our website.



Certified to DIN EN ISO 9001 since 1994. For the most recent certificate visit our website.

Electrical Components and Systems for Railway Engineering and Industrial Applications

Connectors

- Connectors manufactured to industry standards
- Connectors to suit the special requirements of communications engineering (MIL connectors)
- Charging connectors for battery-powered machines and systems
- Connectors for railway engineering, including UIC connectors
- Special connectors to suit customer requirements

Snap-action switches

- Snap-action switches with positive opening operation
- Snap-action switches with self-cleaning contacts
- Snap-action switch made of robust polyetherimide (PEI)
- Snap-action switch with two galvanically isolated contact bridges
- Special switches to suit customer requirements

Contactors Emergency disconnect switches

- Single and multi-pole DC contactors
- High-voltage AC/DC contactors
- Contactors for battery powered vehicles and power supplies
- Contactors for railway applications
- Terminal bolts and fuse holders
- DC emergency disconnect switches
- Special contactors to suit customer requirements

Electrics for rolling stock

- Equipment for driver's cab
- Equipment for passenger use
- High-voltage switchgear
- High-voltage heaters
- High-voltage roof equipment
- Equipment for electric brakes
- Design and engineering of train electrics to customer requirements