

1

Connectors

UIC Series

Inter-car jumpers
to UIC 558 VE

Catalogue F120.en

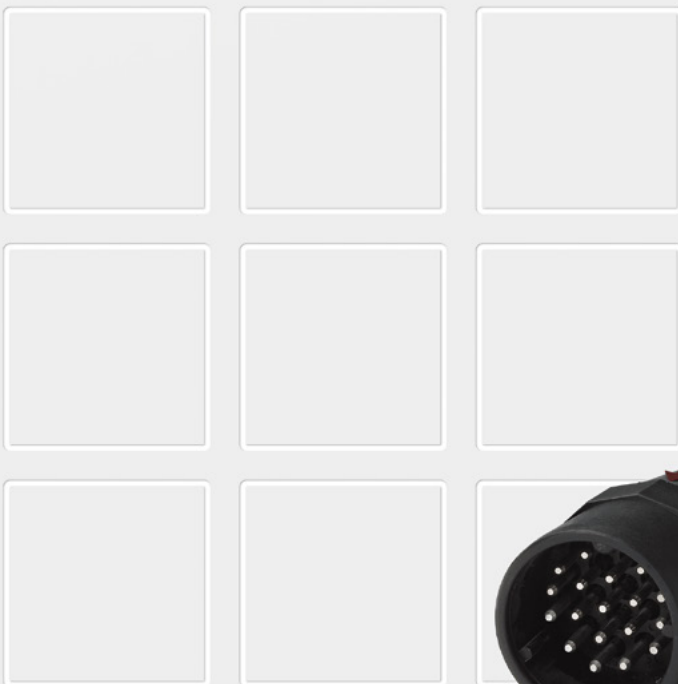

More information
schaltbau.com

UIC Series Inter-car jumpers to UIC 558 VE

Schaltbau jumpers for inter-car connections to UIC standard – cost-effective, durable and highly reliable

The rugged jumpers typically connect lines used for the remote control of lights and train doors or for public address systems in passenger coaches of trains or diesel and electric multiple units. They are also ideally suited for the transmission of binary data, as for instance, via CAN bus.

Break-away connector that ensures, provided the receptacle is installed in the correct position, a non-destructive separation of plug and receptacle when two electrically not decoupled vehicles move apart. The jumpers fully comply with the requirements of UIC 558 VE (until 1994: UIC 568 VE).

Features

UIC series

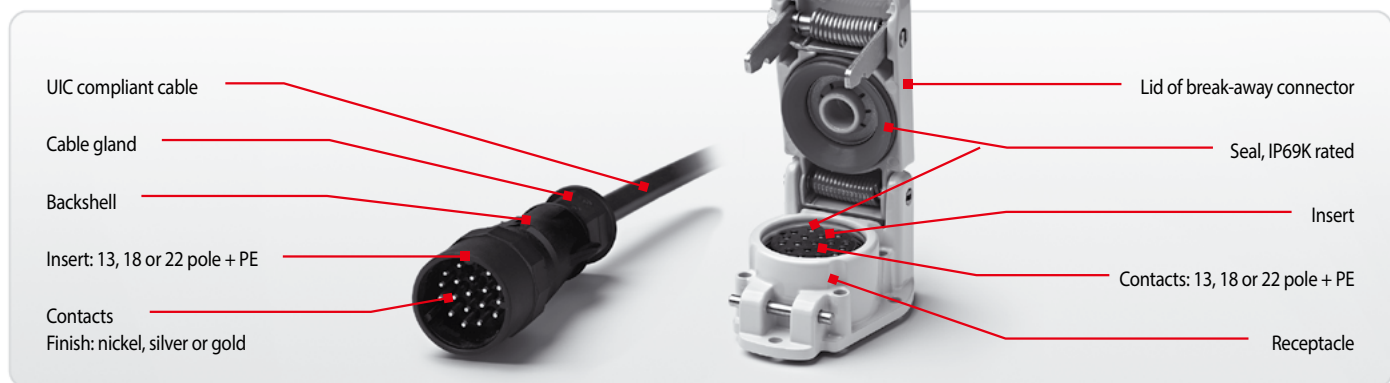

- **Break-away connector:**
Ensures a non-destructive separation of plug and receptacle when two electrically not decoupled vehicles move apart in accordance with UIC 558
- **Design life:**
10,000 mating cycles
- **Cable assembly:**
We supply on request receptacles and plugs assembled complete with cables or wires to suit the customer's specific requirements
- **Seal:**
IP67: receptacle, also empty and dummy receptacle, with closed lid, IP69K: connector when mated; cable entry of plug included
- **Weather proof - and temperature resistant:**
-50° C min. up to +90° C max., no material excluded
- **Corrosion resistant**
Increased corrosion resistance to chemicals, in particular to detergents containing acids or alkalis
- **Assembly:**
 - Suitable for gangway connections
 - Quick and easy to assemble
 - Seals can be replaced without disassembling the contacts
- **Flammability:**
 - UL94-V0 listed
 - Complies with fire protection standard EN 45545
- **Shells:**
Shells of plug, receptacle, dummy and empty receptacle, compliant with UIC 558
- **New: Replacement insert**
Schaltbau has developed a new replacement insert for the receptacle of the UIC 558 connector which is likely to reduce maintenance and downtime considerably. For if during maintenance it becomes necessary to replace worn contacts, there is no need of a cable replacement any longer. All you need do is exchange the replacement insert of the receptacle. You can do that from the front and outside the engine shed and even do without the electrical test of the connector's contacts and wires
- **Receptacle, dummy and empty receptacle:**
Aluminium die cast: rugged and durable
- **Plug:**
Polyamide, glass fibre reinforced
- **Inserts:**
 - 13, 18 and 22 pole + PE
 - Compatible with 13 or 18 pole inserts to UIC standard
 - 13 pole plug intermateable with 18 pole receptacle in accordance with UIC 558 VE
 - Polyamide, glass fibre reinforced
- **Contacts:**
 - High-quality machined contacts
 - Nickel, silver or gold plated
 - Crimp connection 18 ... 17 AWG (0.75 ... 1.00 mm²)
 - Continuous low contact resistance

Specifications

UIC series

UIC Series	Standard	13 pole	18 pole	22 pole + PE
Jumpers to UIC standard	UIC 558 VE (until 1994: UIC 568 VE)	●	●	---
Layout Contact cavities: ○ implemented ○ empty				
Contact arrangement Contact identification marked on insert Pin insert: front view Socket insert: rear view				
Rated operating voltage, no PE	IEC 60038	60 V	60 V	60 V
Rated operating voltage, plus PE	IEC 60038	---	---	110 V
Rated insulation voltage at pollution degree		100 V PD3A	100 V PD3A	100 V / 150 V PD3A / PD3
Current rating of individual contacts		10 A	10 A *1	10 A
Terminal type		Crimp, machined contacts	Crimp, machined contacts	Crimp, machined contacts
Contact diameter		3 mm	3 mm	3 mm
Connector type Cable plug Receptacle Receptacle with replacement insert		Pin contacts Socket contacts ---	Pin contacts Socket contacts Pin contacts, socket contacts in replacement insert	Pin contacts Socket contacts ---
Wire gauge		18 ... 17 AWG	18 ... 17 AWG	18 ... 17 AWG
Contact resistance, typ. with replacement insert	IEC 60512-2	< 4 mΩ ---	< 4 mΩ ≤ 40 mΩ *2	< 4 mΩ ---
Insulation resistance	IEC 60512-3-1	> 10 MΩ	> 10 MΩ	> 10 MΩ
IP rating	EN 60529	IP69K: Plug connection when mated; cable entry of plug included IP67: receptacle, also empty and dummy receptacle, with closed lid		
Shock, Vibration	EN 61373	Category 1, Class B		
Operating temperature range		-50 °C ... +90 °C		
Mechanical endurance	IEC 60512-5, test 9a	10,000 mating cycles		
Shells/Contact material Receptacle shell Colour *3 Plug shell Colour *3 Seal Insert Contacts Finish *3		Aluminium die cast RAL 7035 (light grey) Polyamide PA 6 GF30 black Silicone Polyamide PA 6 GF30 black non-halogen Copper wrought alloy, crimpable Ni / Ag / Au	Aluminium die cast RAL 7035 (light grey) + red bar Polyamide PA 6 GF30 black + red bar Silicone Polyamide PA 6 GF30 black non-halogen Copper wrought alloy, crimpable Ni / Ag / Au	Aluminium die cast RAL 7035 (light grey) + blue bar Polyamide PA 6 GF30 black + blue bar Silicone Polyamide PA 6 GF30 black non-halogen Copper wrought alloy, crimpable Ni / Ag / Au
Approvals				

*1 Current rating of individual contacts with replacement insert: maximum temperature rise 70 K at 10 A, exceeding by far the 30 K at 1 A according to UIC 558 VE.

*2 Contact resistance with replacement insert: after climate test < 200 mΩ typ.

*3 Standard is nickel. Silver or gold plated contacts upon request (not available for BT, CA).

Quality and Safety

UIC series

Rail vehicles in good hands – with Schaltbau connectors

The development, manufacture and assembly of our products are subject to the quality management provisions of DIN EN ISO 9001 and IRIS (International Railway Industry Standard). Continuous testing

guarantees consistently high quality. Your benefit: Great performance at low operating costs. Maximum operating reliability and long lifetime of your rolling stock.

Ordering code

UIC series

Example: **UIC SL 18P ER D2 Lxxxx**

Series

UIC Inter-car jumpers to UIC 558 VE

Plug / receptacle / dummy / empty

- SL Plug, pre-assembled with connector cable
- VK Connector cable, double ended, pre-assembled
- ST Plug
- DL Socket insert, pre-assembled with connector cable
- BT Replacement insert, requiring CA *
- CA Crimp adapter, requiring BT *
- KD Receptacle *
- BD Dummy receptacle with insert, no contacts
- LD Empty receptacle, no insert implemented
- KK Cable gland Pg21 for through hole mounting

Insert: Number of / type of contacts / finish

- 13P Plug: 13 pole pin, nickel plated
- 18P Plug: 18 pole pin, nickel plated
- 22P Plug: 22 pole + PE pin, nickel plated
- 13S Receptacle: 13 pole socket, nickel plated
- 18S/P Replacement insert: 18 pole socket on both ends, nickel plated
- 18S Receptacle: 18 pole socket, nickel plated
- 22S Receptacle: 22 pole + PE socket, nickel plated
- 130-180-220 Dummy receptacle: with insert, no contacts implemented
- 00 Empty receptacle: no insert implemented

Colour of shell

- E for plug: black
- R for plug: red
- C for receptacle: RAL 7035, light grey, acc. to standard
- D for receptacle: RAL 3020, traffic red
- F for receptacle: RAL 7012, basalt grey
- G for receptacle: RAL 5022, night blue
- T for receptacle: RAL 7022, umbra grey
- 0 for socket insert: black

Colour marking

- R red: only for 18 pole jumpers, acc. to standard
- B blue: only for 22 pole +PE jumpers
- 0 none

Cable gland

- D1 only plug: for cable diameters 12.5 ... 15.5 mm
- D2 only plugs: for cable diameters 16.5 ... 18.5 mm

Connector cable

- Lxxxx Cable length (for assembled cable sets only with the length you require)
Length in mm

* For ordering a pre-assembled receptacle with replacement insert and crimp adapter, see page 5 under stock items and page 8 also.



Note:

This catalogue shows only stock items. For some variants minimum quantities apply. Please ask for the conditions.

Special variant:

If you need a special variant of the connector, please do not hesitate to contact us. Maybe the type of connector you are looking for is among our many special designs. If not, we can also supply customized designs. In this case, however, minimum ordering quantities apply.

Stock items Variants for 18 pole jumpers

UIC series

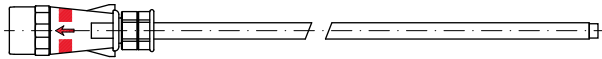
UIC SL 18P ER Lxxxx Connector cable, single ended

UIC	Series
SL	Plug with single ended connector cable
18P	18 pole, pins, nickel plated
E	Colour of backshell: black
R	Colour marking of backshell: red
Lxxxx	Cable length in mm as required

UIC VK 18P ER Lxxxx Connector cable, double ended

UIC	Series
VK	Plug with double ended connector cable
18P	18 pole, pins, nickel plated
E	Colour of backshell: black
R	Colour marking of backshell: red
Lxxxx	Cable length in mm as required

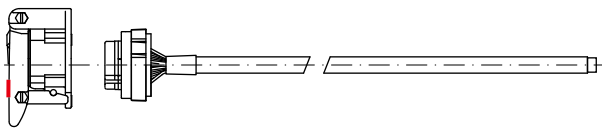
Receptacle with insert and connector cable, including:

① ②

① UIC LD 180 CR Empty receptacle

UIC	Series
LD	Empty receptacle
180	with insert, no contacts
C	RAL 7035, light grey
R	Colour marking of shell: red

② UIC DL 18S 00 Lxxxx Socket insert

UIC	Series
DL	Socket insert with connector cable
18S	18 pole, sockets, nickel plated
0	Colour of insert: black
0	Colour marking: none
Lxxxx	Cable length in mm as required

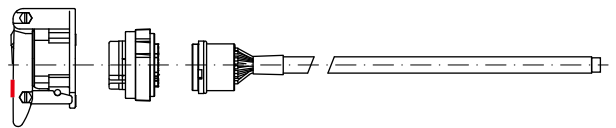
Receptacle with replacement insert, adapter and connector cable, including:

① ②a ②b

① UIC LD 180 CR ZW Empty receptacle

UIC	Series
LD	Empty receptacle
180	with insert, no contacts
C	RAL 7035, light grey
R	Colour marking of shell: red
ZW	Empty receptacle with centring guide

②a UIC BT 18S/P Replacement insert

UIC	Series
BT	Replacement insert, only together with crimp adapter
18S/P	18 pole, sockets, implemented at both ends, nickel plated

②b UIC CA 18P 00 Lxxxx Crimp adapter with connector cable

UIC	Series
CA	Crimp adapter
18P	18 pole, pins, nickel plated
0	Colour of insert: black
0	Colour marking: none
Lxxxx	Cable length in mm as required

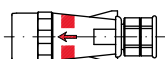
UIC ST 18P ER D2 Plug

UIC	Series
ST	Plug
18P	18 pole, pins, nickel plated
E	Colour of backshell: black
R	Colour marking of backshell: red
D2	Cable gland Ø 16.5 ... 18.5 mm

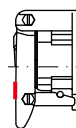
UIC KD 18S CR Receptacle

UIC	Series
KD	Receptacle
18S	18 pole, sockets, nickel plated
C	RAL 7035, light grey
R	Colour marking of shell: red

Connector cable pre-assembled cable sets for plugs

UIC series

● **UIC SL 13P E0 Lxxxx** 13 pole plug with single ended connector cable

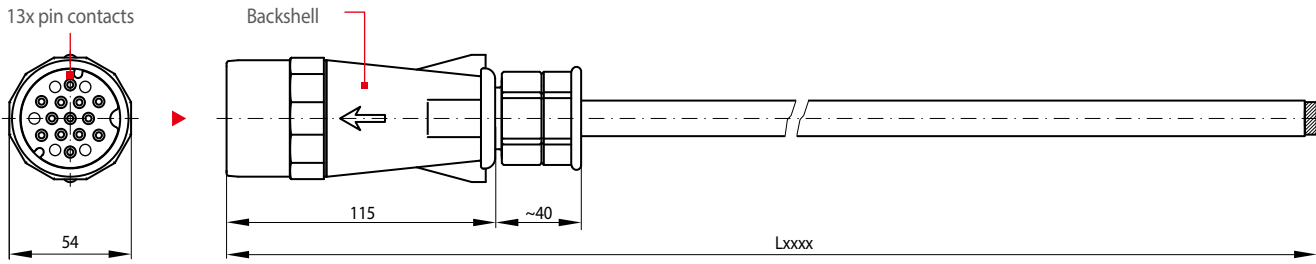

Single ended connector cable with 13 pole plug and cable harness, pre-assembled with the length you require

Layout	Ordering code	Colour	# of contacts	Length
	UIC SL 13P E0 Lxxxx	black, no colour marking	13 pins	Cable length Lxxxx in mm

Cable length Lxxxx	Tolerance
≤ 2,000 mm	± 20 mm
> 2,000 mm, ≤ 4,000 mm	± 30 mm
> 4,000 mm, ≤ 10,000 mm	± 60 mm
> 10,000 mm	± 80 mm

i Note:
13 pole plug, with 18 wire connector cable (5 wires not used)

● **UIC SL 18P ER Lxxxx** 18 pole plug with single ended connector cable

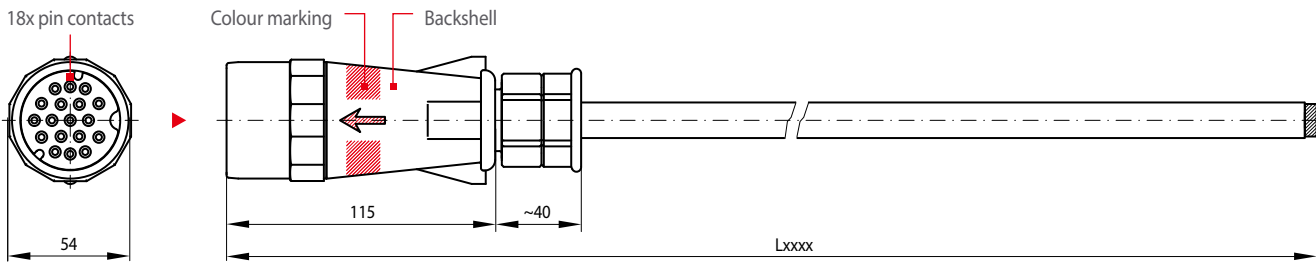

Single ended connector cable with 18 pole plug, pre-assembled with the length you require

Layout	Ordering code	Colour	# of contacts	Length
	UIC SL 18P ER Lxxxx	black, red colour marking	18 pins	Cable length Lxxxx in mm

Cable length Lxxxx	Tolerance
≤ 2,000 mm	± 20 mm
> 2,000 mm, ≤ 4,000 mm	± 30 mm
> 4,000 mm, ≤ 10,000 mm	± 60 mm
> 10,000 mm	± 80 mm

Connector cable pre-assembled cable sets for plugs

UIC series

● **UIC VK 13P E0 Lxxxx, UIC VK 18P ER Lxxxx** 18 pole double ended connector cables with 2 plugs

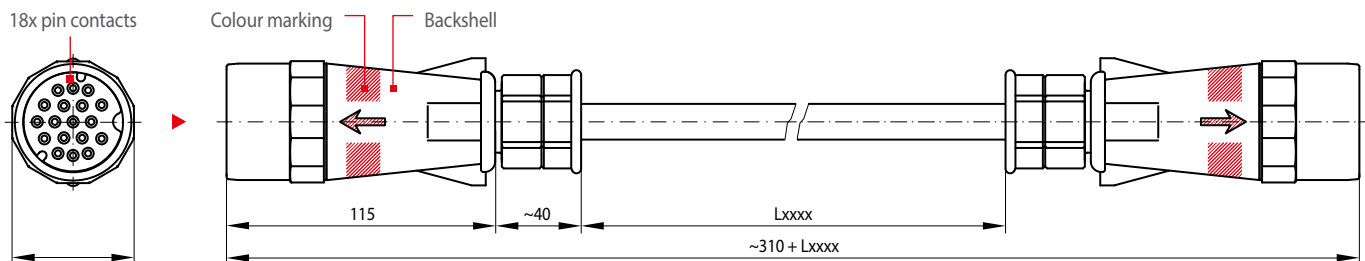

Double ended connector cables with plugs, pre-assembled with the length you require

Layout	Ordering code	Colour	# of contacts	Length
	UIC VK 13P E0 Lxxxx	black, no colour marking	13 pins	Cable length Lxxxx in mm
	UIC VK 18P ER Lxxxx	black, colour marking: red	18 pins	Cable length Lxxxx in mm

Cable length Lxxxx	Tolerance
≤ 2,000 mm	± 20 mm
> 2,000 mm, ≤ 4,000 mm	± 30 mm
> 4,000 mm, ≤ 10,000 mm	± 60 mm
> 10,000 mm	± 80 mm

i Note:
13 pole plug, with 18 wire connector cable (5 wires not used)

Connector cable pre-assembled cable sets for receptacles

UIC series

- 13 pole receptacle with socket insert and single ended connector cable, including:

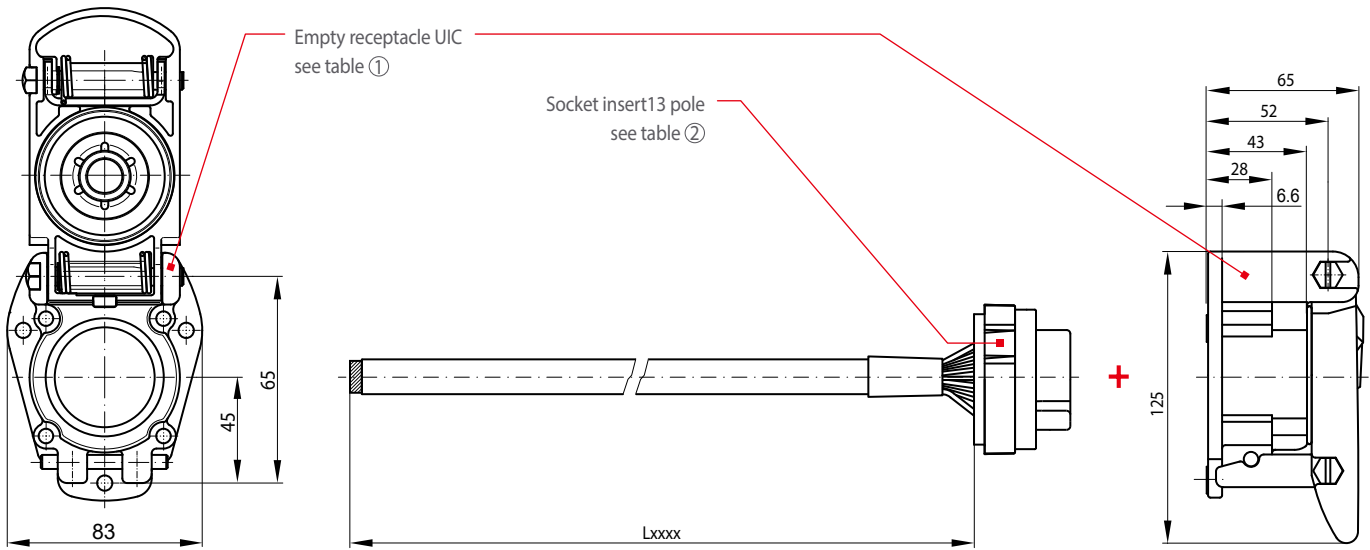

Empty receptacle, see Fig. ①

Ordering code	Colour
UIC LD 130 C0	RAL 7035, light grey

Socket insert with single ended connector cable, pre-assembled with the length you require, see Fig. ②

Layout	Ordering code	# of contacts	Length
	UIC DL 135 00 Lxxxx	13 sockets	Cable length Lxxxx in mm

Cable length Lxxxx	Tolerance
≤ 2,000 mm	± 20 mm
> 2,000 mm, ≤ 4,000 mm	± 30 mm
> 4,000 mm, ≤ 10,000 mm	± 60 mm
> 10,000 mm	± 80 mm

i Note:
13 pole socket insert with 18 wire connector cable (5 wires not used)

- 18 pole receptacle with socket insert and single ended connector cable, including:

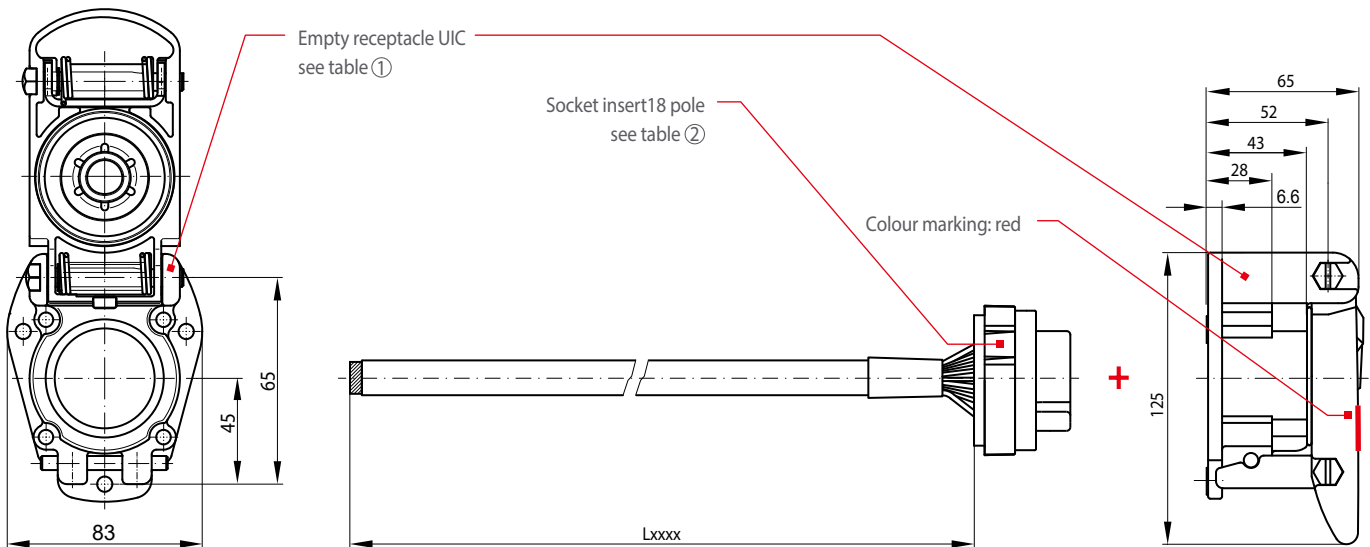

Empty receptacle, see Fig. ①

Ordering code	Colour
UIC LD 180 CR	RAL 7035, light grey Colour marking: red

Socket insert with single ended connector cable and cable harness, pre-assembled with the length you require, see Fig. ②

Layout	Ordering code	# of contacts	Length
	UIC DL 185 00 Lxxxx	18 sockets	Cable length Lxxxx in mm

Cable length Lxxxx	Tolerance
≤ 2,000 mm	± 20 mm
> 2,000 mm, ≤ 4,000 mm	± 30 mm
> 4,000 mm, ≤ 10,000 mm	± 60 mm
> 10,000 mm	± 80 mm

Replacement insert for receptacle pre-assembled

UIC series

• Replacement insert for 18 pole receptacles

Schaltbau has developed a new replacement insert for the 18 pole receptacle which is likely to reduce maintenance and downtime considerably. For if during maintenance it becomes necessary to re-

place worn contacts, there is no need of a cable replacement any longer. All you need do is exchange the replacement insert of the receptacle. You can do that from the front and outside the engine shed and even do without the electrical test of the connector's contacts and wires.

Features

- Replacement insert implemented with sockets on both ends
- Crimp adapter with pre-assembled cable
- Insert can be replaced on site
- No need of rewiring the rail vehicle
- No need of electrical testing the jumper's contacts and wires

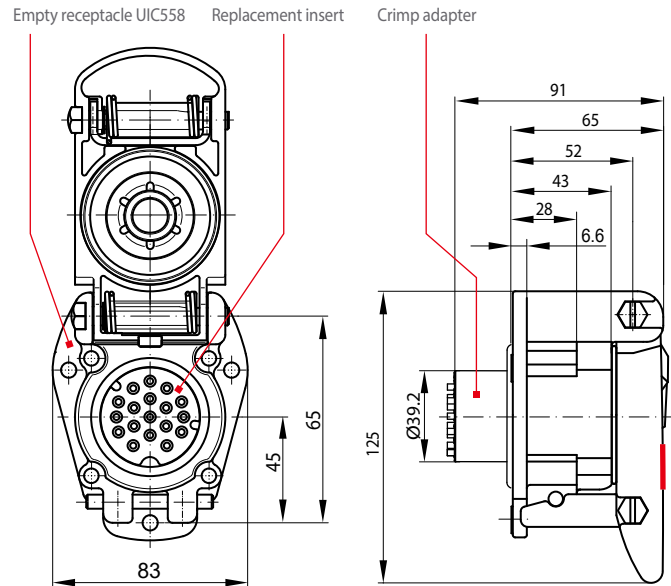
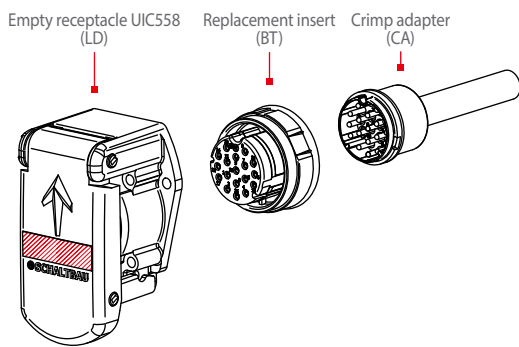

• 18 pole receptacle with replacement insert, crimp adapter and single ended connector cable, including:

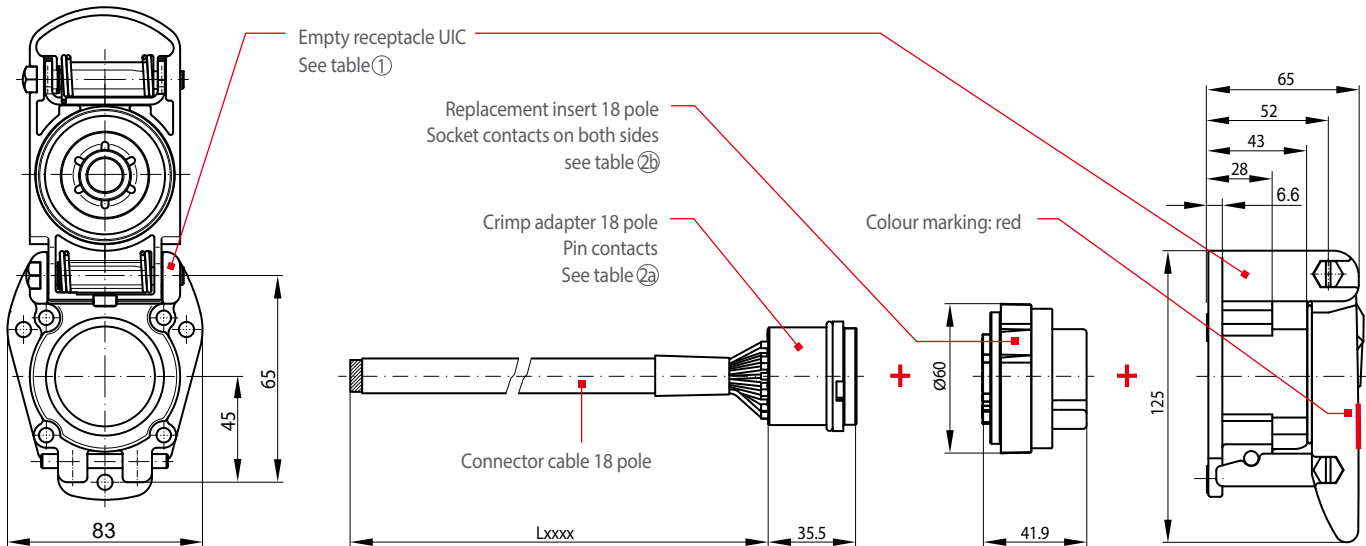

Cable length Lxxxx	Tolerance
≤ 2,000 mm	± 20 mm
> 2,000 mm, ≤ 4,000 mm	± 30 mm
> 4,000 mm, ≤ 10,000 mm	± 60 mm
> 10,000 mm	± 80 mm

Empty receptacle
Table 1

Ordering code	Colour
UIC LD 180 CR ZW	RAL 7035, light grey Colour marking: red

Replacement insert 18 pole
Table 2a

Layout	Ordering code
	UIC BT 18S/P

Crimp adapter 18 pole with single ended connector cable,
pre-assembled with the length you require, see Table 2b

Layout	Ordering code	# of contacts	Length
	UIC CA 18P 00 Lxxxx	18 pins	Cable length Lxxxx in mm

Plug

UIC series

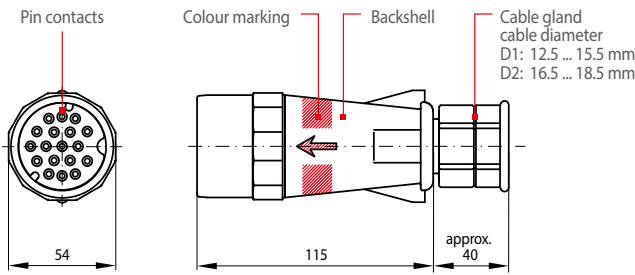

Ordering code	# of contacts	Colour	Cable gland
UIC ST 13P E0 D1	13	black	for cable Ø 12.5 ... 15.5 mm
UIC ST 18P ER D2	18	black Colour marking: red	for cable Ø 16.5 ... 18.5 mm
UIC ST 22P EB	22	black Colour marking: blue	for cable Ø 16.5 ... 18.5 mm



Note:

- All pin contacts included in delivery
- For other options, such as different shell colours, refer to Ordering code, p. 4, or contact us

Receptacle, dummy and empty receptacle

UIC series

- Receptacle, dummy: 13, 18, 22 pole

- Empty receptacle: Shell only

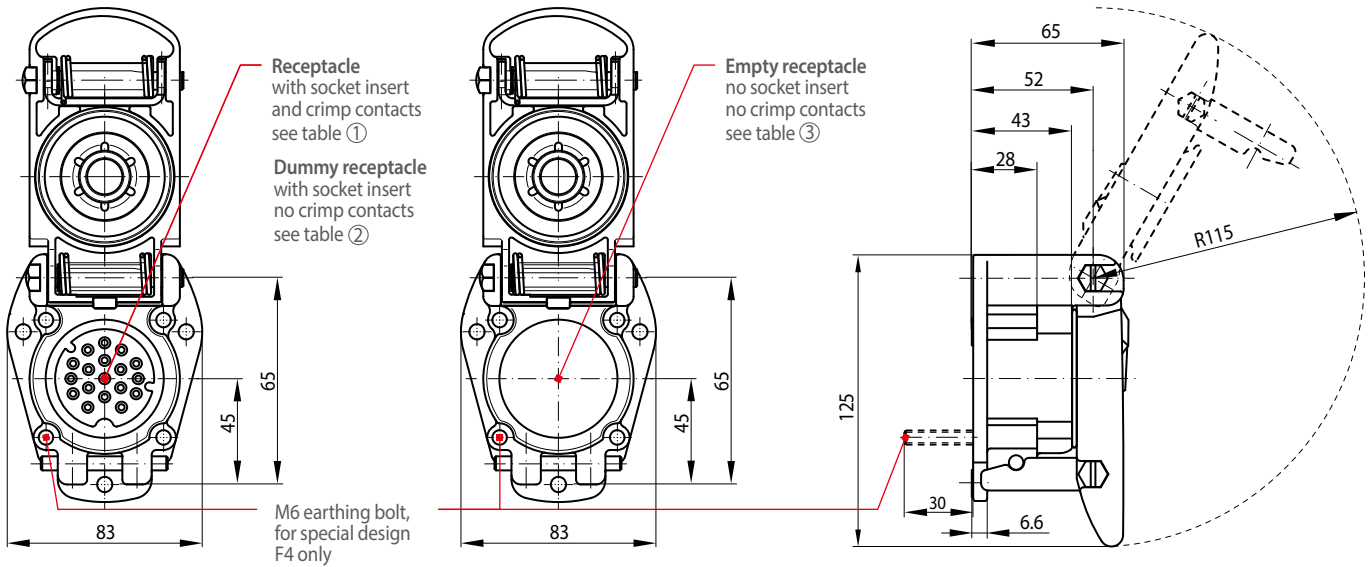

Receptacle, Table ①

Ordering code	# of contacts
UIC KD 13S C0	13
UIC KD 18S CR	18
UIC KD 22S CB	22

Dummy receptacle, Table ②

Ordering code	# of contacts
UIC BD 130 C0	13
UIC BD 180 CR	18
UIC BD 220 CB	22

Empty receptacle, Table ③

Ordering code	# of contacts
UIC LD 130 C0	---
UIC LD 180 CR	---
UIC LD 220 CB	---

Colour
RAL 7035, light grey
RAL 7035, light grey Colour marking: red
RAL 7035, light grey Colour marking: blue



Note:

- All socket contacts included in delivery
- For options, such as switching contact, earthing bolt or other shell colours, refer to Ordering code, p. 4, or contact us.

Pin and socket contacts

UIC series

- Pin contact

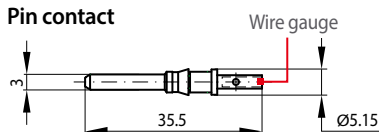

- Socket contact

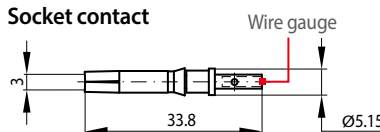

Pin contact

Ordering code	Finish
SHC-1,00-Ni-30	Nickel
SHC-1,00-Au-30	Gold*
SHC-1,00-Ag-30	Silver*

Socket contact

Ordering code	Finish
BHC-1,00-Ni-30	Nickel
BHC-1,00-Au-30	Gold*
BHC-1,00-Ag-30	Silver*

Specifications

Wire gauge	Current rating
18 ...17 AWG	10 A
18 ...17 AWG	10 A
18 ...17 AWG	10 A

* Special design, upon request

Cable gland for through hole mounting

UIC series

● **Pg21 antikink cable glands:**

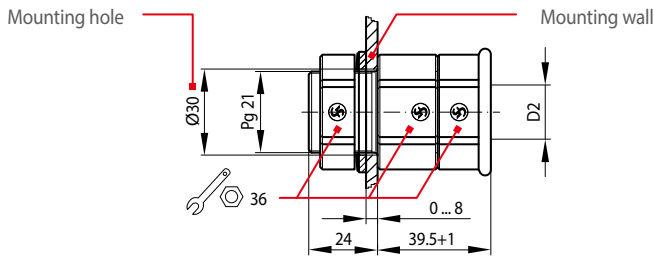

i **Delivery:**
Kit including the parts mentioned above.
All parts individually packed.

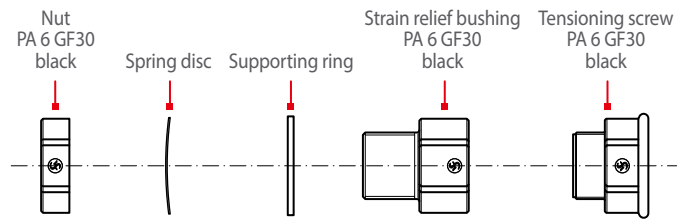

Ordering code	Description
UIC KK D1	Cable diameter 12.5 ...15.5 mm
UIC KK D2	Cable diameter 16.5 ...18.5 mm

Assembly and disassembly

UIC series

● **Crimp tool**



Ordering code	Crimp tool for
CWZ-600-1	Contacts, type H: SHC-x, BHC-x

● **Extraction tool**



Ordering code	Extraction tool for
AWZ-B	Contacts, type H: SHC-x, BHC-x

● **Extraction tool (not shown)**

Ordering code	Extraction tool for
UIC-DWZ	Extraction of crimp adapter from replacement insert

Cable 18pole cable connectors, single and double ended

UIC series

Both single and double ended 18 pole cable connectors comply with the EN 45545 standard and are delivered by the metre.

Ordering code: **UIC558 adapter cable 18-pin**

- Train bus: 1 x 2 x 18 AWG, wires 17, 18
- Signal cable: 4 x 4 x 17 AWG, wires 1 ... 12, 14 ... 16
- Shielded cable: Overall screen, Cu braid, wire 13

i **Note:**
This type of cable is used for our pre-assembled 13 and 18 pole cable sets. The 18 wire cable is also used for 13 pole jumpers. In this case, however, 5 wires remain unconnected.

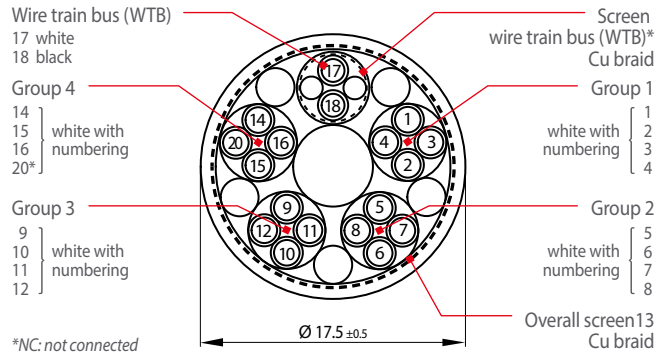

Mounting, holes, orientation

UIC series

Schaltbau standard: »3 hole mounting«

»4 hole mounting«

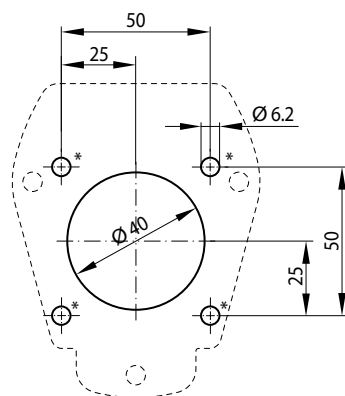
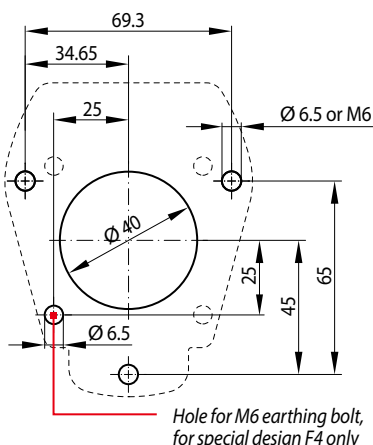

Mounting orientation

As break-away connector the jumper ensures in compliance with UIC 558 a non-destructive separation of plug and receptacle when two electrically not decoupled vehicles move apart. To this end make sure to mount the receptacle upright onto the front end of the vehicle or carriage, so that the lid opens upwards.

* Diameter for all fixing and securing elements, such as screw heads: 12.5 mm max.

Installation and safety instructions

UIC series

The UIC Series inter-car jumpers dealt with in this catalogue are intended for use with low-voltage systems and special installations. They are designed and tested in compliance with the generally recognised state of the art. However, the improper use, operation, handling,

maintenance of or tampering with electric equipment can cause serious or fatal injury to the user or others, and the appliance or other property can be damaged.



Due to our continuous improvement programme, the design of our products can be modified at any time. So some features may differ from the descriptions, specifications and drawings in the catalogue.

You can download the latest update of the catalogue at schaltbau.info/download1en. The updated catalogue renders the previous issue invalid.



Electrical hazards: Any exposure to the connector's live parts. Risk of electrical shock!

Observe all applicable national provisions, all safety, accident prevention and environmental regulations as well as the recognized technical rules for safe and proper working.

- Only authorized and trained personnel are allowed to plan and carry out all mechanical and electrical installations, transport, commissioning, as well as maintenance and repair work.
- This applies to the observation of the general installation and safety regulations for low-voltage systems as well as the proper use of tools approved for this purpose. Electric equipment requires protection from moisture and dust during installation, operation and storage.
- Electrical hazards: Any exposure to the connector's live parts. Risk of electrical shock!
- Work on electric equipment may only be performed by a qualified electrician or trained personnel working under the direction and supervision of a qualified electrician according to the applicable rules of electrical engineering.
- Observe all applicable national provisions, all safety, accident prevention and environmental regulations as well as the recognized technical rules for safe and proper working.
- Carry out regular inspections of all protection and safety devices to see if they work properly.
- Work on electric equipment may only be performed by a qualified electrician or trained personnel working under the direction and supervision of a qualified electrician according to the applicable rules of electrical engineering.
- The connectors supply power and signals. They are intended for plug-in and detachable connections of components, devices and systems only.
- In order to comply with IEC 61984 make sure that always the live side of the connector – no matter whether plug or receptacle – is fitted with socket contacts. Crimp connections have to be manufactured according to IEC 60352-2 – Solderless Connections.
- Make sure that there is no undue strain, pressure, flexing and torsion on the cable connection.
- For optimum protection of the cable connection make sure the connector is supplied with a strain relief.
- According to IEC 61984 connectors used as intended must not be engaged or disengaged when live or under load.
- Crimp connections have to be manufactured according to IEC 60352-2 – Solderless Connections.
- When disengaging a connector, pull the plug and never the cable.
- A connector that does not engage easily requires special attention: Check for the correct orientation, pollution or if contacts got bent. Remedy the cause without delay. Never use force! The connector should always engage easily.
- In order to meet the requirements of the protection class and to protect the connectors against the entry of dirt or moisture, make sure that, when not mated,
 - the plug is always inserted into a dummy receptacle
 - the hinged lid of receptacles is closed, according to its intended use
- Use the connector only according to its intended use. Replace or repair damaged parts exclusively with original parts. Any other usage of or tampering with the connector is considered contrary to its intended use. No liability is assumed for damages and accidents caused due to non-compliance with the instructions or improper use of the connector.
- The connectors are constructed for specific ambient conditions. Operate the connectors only under the ambient conditions, like temperature ranges and IP protection classes as defined in our catalogue on page 3 "Specifications".

Installation and maintenance manual



For a detailed list of all safety, installation and maintenance instructions, download our manual

➔ [F120-M.en](https://schaltbau.info/F120-M.en)!

Visual inspections

Be sure to make visual inspections regularly. Improper handling of the connector, e.g. when hitting the floor with some impact, can result in breakage, visible cracks and deformation.



Defective and/or leaky parts must be replaced instantaneously!

Schaltbau GmbH

For detailed information on our products and services visit our website – or give us a call!

Phone +49 89 9 30 05-0
Internet www.schaltbau.de
e-mail contact@schaltbau.de

Find your worldwide contact person. We are here for you, personally!



with compliments:



The production facilities of Schaltbau GmbH have been IRIS certified since 2008.



Certified to DIN EN ISO 14001 since 2002. For the most recent certificate visit our website.



Certified to DIN EN ISO 9001 since 1994. For the most recent certificate visit our website.

Electrical Components and Systems for Railway Engineering and Industrial Applications

Connectors

- Connectors manufactured to industry standards
- Connectors to suit the special requirements of communications engineering (MIL connectors)
- Charging connectors for battery-powered machines and systems
- Connectors for railway engineering, including UIC connectors
- Special connectors to suit customer requirements

Snap-action switches

- Snap-action switches with positive opening operation
- Snap-action switches with self-cleaning contacts
- Snap-action switch made of robust polyetherimide (PEI)
- Snap-action switch with two galvanically isolated contact bridges
- Special switches to suit customer requirements

Contactors Emergency disconnect switches

- Single and multi-pole DC contactors
- High-voltage AC/DC contactors
- Contactors for battery powered vehicles and power supplies
- Contactors for railway applications
- Terminal bolts and fuse holders
- DC emergency disconnect switches
- Special contactors to suit customer requirements

Electrics for rolling stock

- Equipment for driver's cab
- Equipment for passenger use
- High-voltage switchgear
- High-voltage heaters
- High-voltage roof equipment
- Equipment for electric brakes
- Design and engineering of train electrics to customer requirements