

1

Connectors

LV80/120, LV160/250,
LV320/400, LV500

High power charging connectors
for DC applications

Assembly instructions

Manual A84-M.en

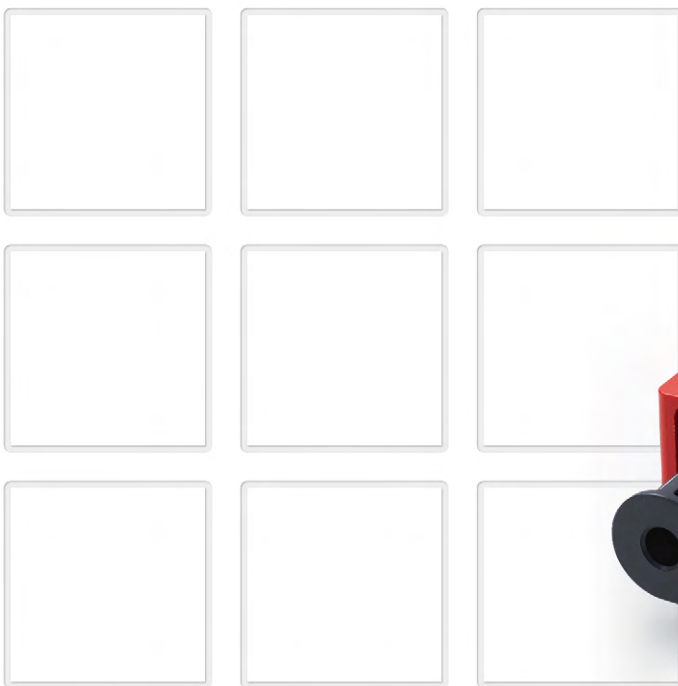

Document revision

Date	Version	Description	Pages
08.07.2023	V1.0	Initial version	All

Content



1. Charger and vehicle plug	3
Basic set components	3
Optional additional components	3
1.1 Cable preparation	3
Tools required	3
Strip off the insulation from the cables for the main contacts	3
Crimp the cables at the main contacts	4
Fit the heat shrink tube for the main contacts	4
Strip the cables for pilot/auxiliary contacts (optional additional component)	4
Crimp the cables to the pilot/auxiliary contacts (optional additional component)	5
1.2 Assembling the charger and vehicle plug	6
Tools required	6
Assembly steps overview	6
Install the main contacts in the charger/vehicle plug	6
Install the pilot contacts in the charger/vehicle plug (optional additional component)	7
Install the air tube in the charger plug (optional additional component, only for wet-cell battery applications)	7
Install the auxiliary contacts in the charger/vehicle plug (optional additional component)	7
Install the coding pin in the charger/vehicle plug (optional additional component)	8
Install the slider in the charger/vehicle plug	8
Install the strain relief on the charger/vehicle plug	9
Install the handle on the charger/vehicle plug (optional additional component)	9
2. Battery socket	10
Basic set components	10
Optional additional components	10
2.1 Cable preparation	10
Tools required	10
Strip off the insulation from the cables for the main contacts	11
Crimp the cables at the main contacts	11
Fit the heat shrink tube for the main contacts	11
Strip the cables for pilot/auxiliary contacts (optional additional component)	12
Crimp the cables to the pilot/auxiliary contacts (optional additional component)	12
2.2 Assembling the battery socket	13
Tools required	13
Assembly steps overview	13
Install the main contacts in the battery socket	13
Install the pilot contacts into the battery socket for pilot contacts (optional additional component)	14
Install the air tube and spacer in the battery socket with air tube (optional additional component, only for wet-cell battery applications)	14
Install the auxiliary contacts in the battery socket (optional additional component)	14
Install the coding pin in the battery socket (optional additional component)	15
Install the slider in the battery socket	15
Install the strain relief in the battery socket	16
Install the handle on the battery socket (optional additional component)	16
3. Disassembly of pilot and auxiliary contacts	17
Tools required	17
Disassemble pilot and auxiliary contacts	17
4. Tools	18
4.1 Crimping tools	18
4.2 Crimp insert sets for CTH-U/≤300 and CTE-U/≤400 for main contacts	18
4.3 Extraction tools for pilot and auxiliary contacts	19

1. Charger and vehicle plug

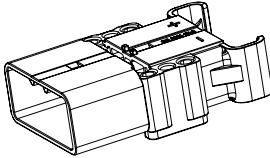
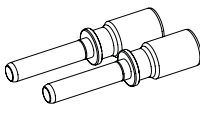
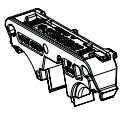
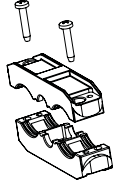
Basic set components

			
Plug housing	Main contact pin	Contact lock (slider)	Strain relief

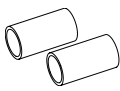
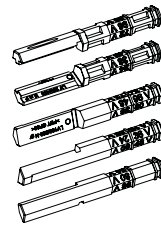
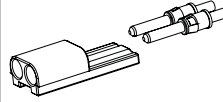
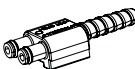
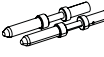
Optional additional components

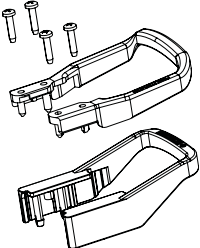
		 or optionally 			
Reducing bushings for main contacts for reducing the connection cross section - from 25 to 10 mm ² - from 25 to 16 mm ² - from 50 to 25 mm ² - from 50 to 35 mm ²	Keying 24-36-48-72-80-96 V - Blue: Lithium-ion battery - Red: Wet-cell battery, high power - Grey: Wet-cell battery - Green: Dry-cell battery - Yellow: Vehicle plug, universal	1x pilot contact adapter incl. 2x pin contacts or optionally 1x air tube	Auxiliary contacts (2x pin contacts)	Reducing bushings for pilot/auxiliary contacts for reducing the connection cross section - from 2.5 to 1.5 mm ² - from 2.5 to 1.0 mm ² - from 2.5 to 0.5 mm ²	Handle - Screw-on, black incl. screws - Screw-on, red incl. screws - Snap-on, black - Snap-on, red

1.1 Cable preparation

Tools required

- Insulation stripping tool
- Crimping tools, crimp inserts (see section "4. Tools")
- Heat-shrink device, e.g. hot air gun

1 Strip off the insulation from the cables for the main contacts

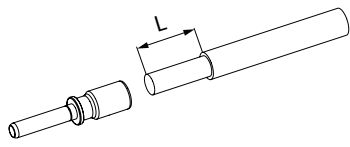

Fig. 1:

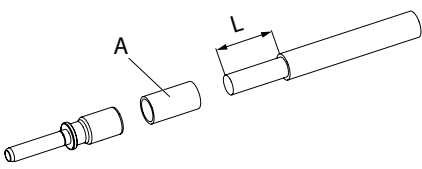

Fig. 2:

1. Strip cables for the main contacts - depending on the series and wire cross-section - to length L as indicated in the table below (Fig. 1).
If a reduction of the connection cross section is necessary, use reducing bushing (A) (Fig. 2).

Series	Wire cross section [mm ²]	With reducing bushing (A)	Stripping length L [mm]
LV80/120	10	Rb-25/10	18
	16	Rb-25/16	
	25	-	
LV160/250	25	Rb-50/25	20
	35	Rb-50/35	
	50	-	
LV320/400	35	Rb-50/35	20
	50	-	
	70	-	
	95	-	
	AWG 4/0	-	25
LV500	AWG 4/0	-	25

2 Crimp the cables at the main contacts

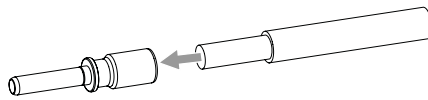

Fig. 3:

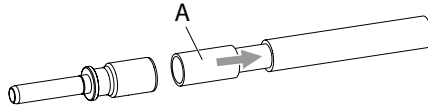

Fig. 4:

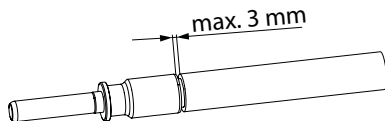

Fig. 5:

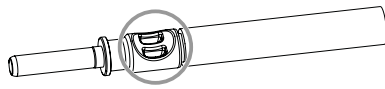

Fig. 6:

Without use of reducing sleeves:

1. Push the bare cable braid into the connection area of the contact (*Fig. 3*).

With use of reducing bushings:

1. Push the reducing bushing (A) as shown in *Fig. 4* onto the bare cable braid and push the cable braid together with the reducing bushing into the connection area of the contact.
2. When doing so, ensure that the gap between insulation and contact is not more than 3 mm (*Fig. 5*).
3. Insert a crimp insert suitable for the wire cross section into the crimp tool (see section "4. Tools").
4. Crimp contact and cable (if necessary including the reducing bushing) as shown in *Fig. 6*.

3 Fit the heat shrink tube for the main contacts

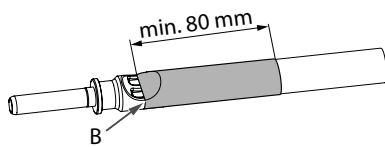

Fig. 7:

1. Cut the heat shrink tube to the required length (at least 80 mm) plus 5-10 % heat shrink tube allowance (*Fig. 7*). In doing so ensure the cut edges are even.
2. Push the heat shrink tubing onto the cable and contact so that the end is positioned centrally within the crimping area on the contact (*Fig. 7/B*). Prevent any creasing.
3. Using a heat shrink device, e.g. a hot air gun, heat the heat shrink tubing with up and down movements until the heat shrink tubing lies smoothly without any creases against the contact and cable.

4 Strip the cables for pilot/auxiliary contacts (optional additional component).

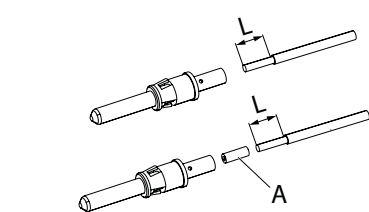

Fig. 8: Pilot contacts

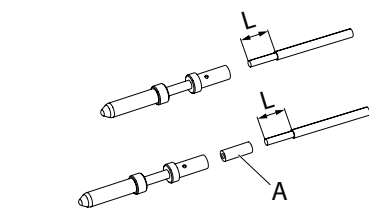

Fig. 9: Auxiliary contacts

1. Strip the cables for the pilot/auxiliary contacts to length L as indicated in the table below (*Fig. 8* or *Fig. 9*). If a reduction of the connection cross section is necessary, use reducing bushing (A) (*Fig. 8* or *Fig. 9*).

Series	Wire cross section [mm ²]	With reducing bushing (A)	Stripping length L [mm]
LV80/120	0.5	Rb-2.5/0.5	7.5
LV160/250	1.0	Rb-2.5/1.0	
LV320/400	1.5	Rb-2.5/1.5	
LV500	2.5	-	

5 Crimp the cables to the pilot/auxiliary contacts (optional additional component).

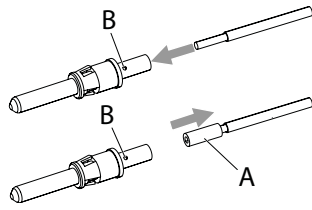

Fig. 10: Pilot contacts

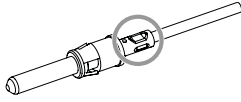

Fig. 11: Pilot contacts

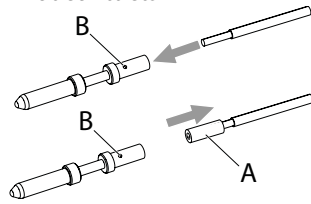

Fig. 12: Auxiliary contacts

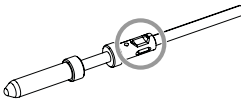

Fig. 13: Auxiliary contacts

Note: For series LV80/120, pilot and auxiliary contacts have the same design.

Without use of reducing sleeves:

1. Push the bare cable braid into the connection area of the contact (*Fig. 10* or *Fig. 12*).

With use of reducing bushings:

1. Push the reducing bushing (A) as shown in *Fig. 10* or *Fig. 12* onto the bare cable braid and push the cable braid together with the reducing bushing into the connection area of the contact.
2. Push the cable braid (if necessary including the reducing bushing) into the contact until it is visible in the checking hole (*Fig. 10/B* or *Fig. 12/B*)
3. Crimp contact and cable (if necessary including the reducing bushing) using the crimping tool (see section "4. Tools"), as shown in *Fig. 11* or *Fig. 13*.

1.2 Assembling the charger and vehicle plug

Tools required

- Crosshead screwdriver PH2 and PH3
- Slotted screwdriver no. 3
- Torque wrench

Assembly steps overview

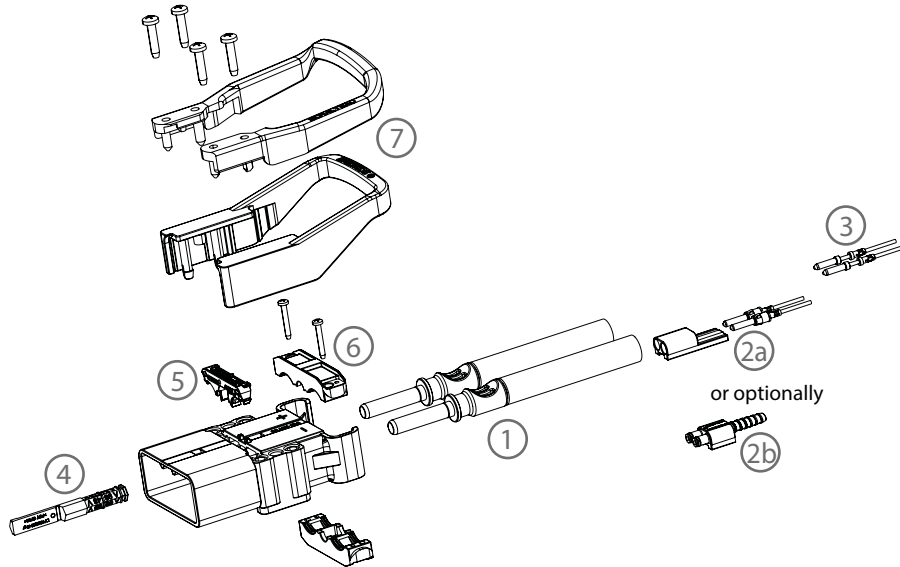

Fig. 14:

The assembly steps ① to ⑦ are described in detail on the following pages.

① Install the main contacts in the charger/vehicle plug

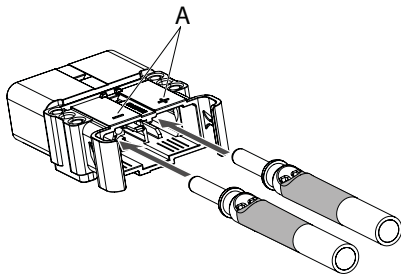

Fig. 15:

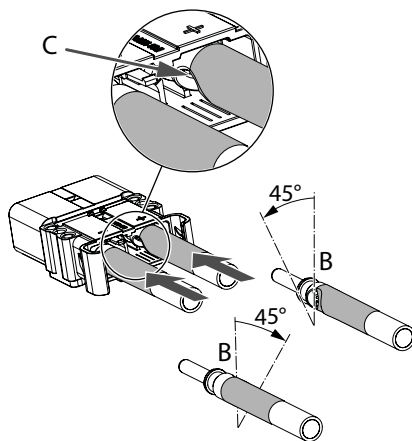

Fig. 16:

⚠ WARNING

An incorrect connection could result in a fatal electric shock. Observe the polarity markings (+) and (-) on the housing of the charger/vehicle plug (Fig. 15/A).

1. Push in the main contacts with crimped cables as far as they will go into the plug housing (Fig. 15).

Note: Only applies for contact sizes 95 mm² and AWG 4/0.

1. Turn the crimp area (B) to about 45° from vertical (Fig. 16/B).
2. Push in the main contacts so that the crimping area points downwards at an angle towards the inside of the plug, as shown in (Fig. 16/C).

2a) Install the pilot contacts in the charger/vehicle plug (optional additional component)

Either a pilot contact adapter with pilot contacts or an air tube (only for charger plug) can be installed.

Optionally

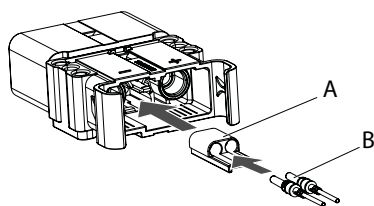

Fig. 17:

1. Push the pilot contact adapter (Fig. 17/A) into the plug housing until it audibly clicks into place.
2. After it has clicked into place, check that the pilot contact adapter is firmly seated by pressing on it against the direction of assembly.
3. Push the pilot contacts (Fig. 17/B) with the crimped wires into the contact chambers of the pilot contact adapter as far as they will go until the retaining clip clicks into place.
4. Pull gently on the wires to check whether the pilot contacts are correctly fixed and the retaining clips are engaged.

Note: For disassembly of pilot contacts, see section "3. Disassembly of pilot and auxiliary contacts".

2b) Install the air tube in the charger plug (optional additional component, only for wet-cell battery applications)

Either an air tube (only for charger plugs) or a pilot contact adapter can be installed.

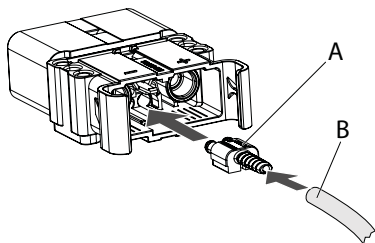

Fig. 18:

Air hose specification

The air hoses for the air tubes must have the following specification:

- Internal Ø 6 mm
- Wall thickness ≤ 1.5 mm
- Shore hardness 73

1. Push the air hose (Fig. 18/B) as far as it will go onto the air tube (Fig. 18/A).
2. Push the air tube with attached air hose into the plug housing until it clicks audibly into place.
3. After it has clicked into place, check that the air tube is firmly seated by pressing on it against the direction of assembly.

3) Install the auxiliary contacts in the charger/vehicle plug (optional additional component)

Note: For the LV320/400 and LV500 series, the auxiliary contacts must be installed with the main contacts because the auxiliary contacts and main contacts are fixed together using the slider.

Only for series LV80/120 and LV160/250:

1. Push the auxiliary contacts with the crimped wires into the contact chambers of the plug housing as far as they will go until they click into place.
2. Pull gently on the wires to check whether the auxiliary contacts are correctly fixed and clicked into place.

Only for series LV320/400 and LV500:

1. Push the auxiliary contacts with the crimped wires into the contact chambers of the plug housing as far as they will go.
2. Check whether the contacts are correctly positioned in the guides in the plug housing so that they can be correctly fixed by the slider.

Note: For disassembly of auxiliary contacts, see section "3. Disassembly of pilot and auxiliary contacts".

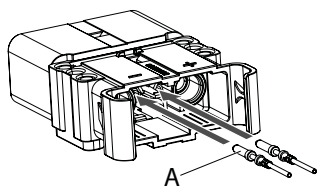

Fig. 19:

4 Install the coding pin in the charger/vehicle plug (optional additional component)

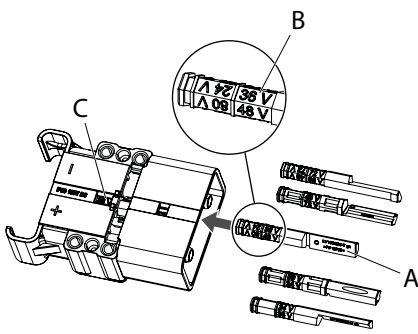

Fig. 20:

1. Rotate the coding pin (*Fig. 20/A*) for the required voltage so that the voltage indication faces upwards.
 - For charger/vehicle plugs, the voltage indication on the front part of the coding pin is defining (*Fig. 20/B*).
 - After insertion, the voltage indication (B) on the coding pin must be visible in the housing cut-out (*Fig. 20/C*).
2. Push the coding pin from the front into the coding pin receiver in the plug and press in firmly until it audibly clicks into place.
 - The voltage indication (B) on the coding pin must now be visible in the housing cut-out (C).

If the coding pin has been incorrectly inserted, drive the coding pin out from the back of the plug and insert it again.

5 Install the slider in the charger/vehicle plug

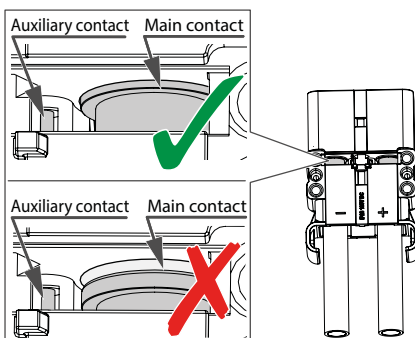

Fig. 21:

Notes:

- For the LV320/400 series, the auxiliary contacts (where used) must be installed with the main contacts because the auxiliary contacts and main contacts are fixed together using the slider.
- For the LV80/120 series, the coding pin for the voltage coding must be fitted before the slider is fitted in place.
- There is no latch on the slider for the LV80/120 series.

1. Ensure that the main contacts and the auxiliary contacts (where used) are correctly positioned in the guides in the housing (*Fig. 21*).
2. Ensure that the latch on the slider is in the unlocked position (*Fig. 22*).
 - Latch pushed fully to the right (C).
 - Recess (D) of the latch and bar (E) of the main body are not aligned over each other.
3. Insert the slider into the housing so that when it is unlocked the logo can be read when viewed from the insertion side.
4. Push the slider in on both sides until it audibly clicks into place (*Fig. 23*).
5. Use a slotted screwdriver to push the latch on the slider as far as it will go (about 4 to 5 mm) into the locked position (*Fig. 24/F*).
6. Ensure that the latch is in the locked position (*Fig. 24*).
 - The latch must be pushed fully to the left into position (F)
 - Recess (D) of the latch and bar (E) of the main body must be aligned over each other.
 - Letter "Z" or a lock symbol is visible to the right on the slider (G).

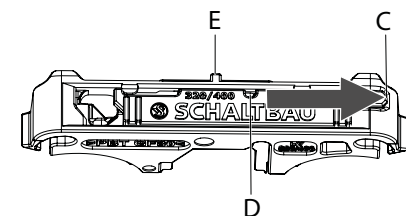

Fig. 22:

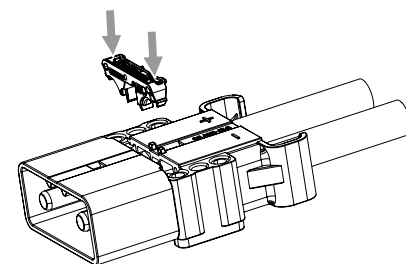

Fig. 23:

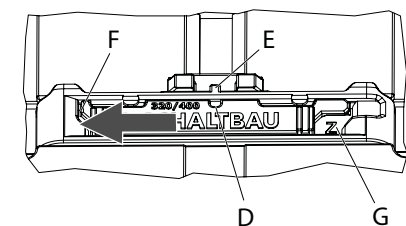

Fig. 24:

6 Install the strain relief on the charger/vehicle plug

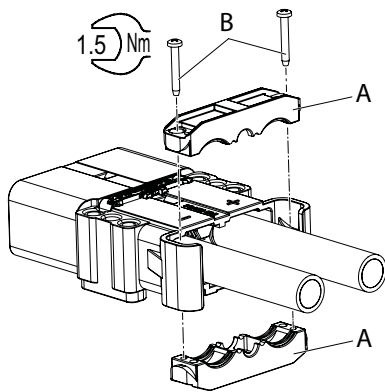

Fig. 25:

Recommendation: Before tightening the strain relief screws (*Fig. 25/B*), connect the charger/vehicle plug to a battery socket and only then tighten the strain relief screws of the plug. This will result in alignment of the main contacts.

1. Position the upper and lower clamp (*Fig. 25/A*) of the strain relief on the cable.
2. Align the cables of the main contacts (as well as the auxiliary contacts/pilot contacts or air hose, where used).
3. Using a PH2 crosshead screwdriver, uniformly tighten the clamps (A) using both screws (B). In doing so, ensure
 - that both screws (B) are uniformly tightened,
 - that the clamps (A) are not tilted or skewed.
4. Tighten both screws (B) to a torque of 1.5 Nm.
5. Check that all cables are reliably secured against strain/pulling.

7 Install the handle on the charger/vehicle plug (optional additional component)

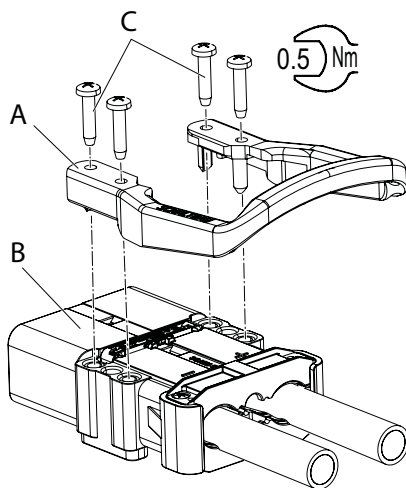

Fig. 26: Screw-on handle

Screw-on handle (*Fig. 26*)

1. Insert the screw-on handle (A) into the provided securing holes on the housing (B).
2. Screw on the handle with a PH3 crosshead screwdriver using the four mounting screws (C).
3. Tighten the four mounting screws to a torque of 0.5 Nm.

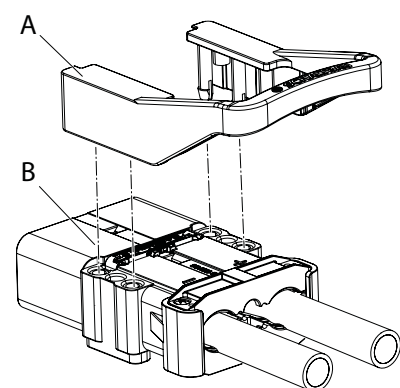

Fig. 27: Snap-on handle

Snap-on handle (*Fig. 27*)



1. Press the snap-on handle (A) into the provided securing holes on the housing (B).

2. Battery socket

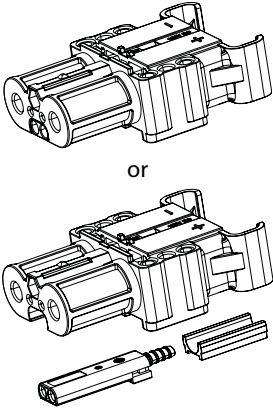
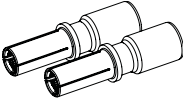
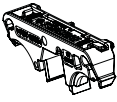
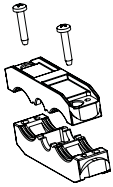
Basic set components

 <p>or</p>			
<p>Battery socket housing for pilot contacts or optionally battery socket housing with air tube</p>	<p>Main contacts socket</p>	<p>Contact lock (slider)</p>	<p>Strain relief</p>

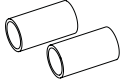
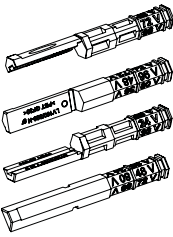
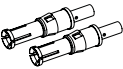
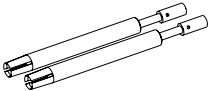
Optional additional components

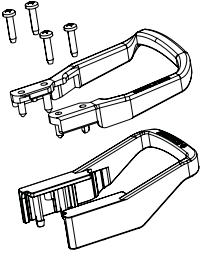
					
<p>Reducing bushings for main contacts for reducing the connection cross section</p> <ul style="list-style-type: none"> - from 25 to 10 mm² - from 25 to 16 mm² - from 50 to 25 mm² - from 50 to 35 mm² 	<p>Keying 24-36-48-72-80-96 V</p> <ul style="list-style-type: none"> - Blue: Lithium-ion battery - Red: Wet-cell battery, high power - Grey: Wet-cell battery - Green: Dry-cell battery 	<p>2x pilot contact socket</p>	<p>2x auxiliary contact socket</p>	<p>Reducing bushings for pilot/auxiliary contacts for reducing the connection cross section</p> <ul style="list-style-type: none"> - from 2.5 to 1.5 mm² - from 2.5 to 1.0 mm² - from 2.5 to 0.5 mm² 	<p>Handle</p> <ul style="list-style-type: none"> - Screw-on, black incl. screws - Screw-on, red incl. screws - Snap-on, black - Snap-on, red

2.1 Cable preparation

Tools required

- Insulation stripping tool
- Crimping tools, crimp inserts, (see section "4. Tools")
- Heat-shrink device, e.g. hot air gun

1 Strip off the insulation from the cables for the main contacts

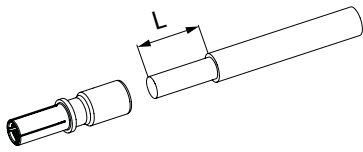

Fig. 28:

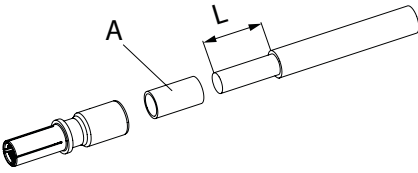

Fig. 29:

2. Strip cables for the main contacts - depending on the series and wire cross-section - to length L as indicated in the table below (Fig. 28).
 If a reduction of the connection cross section is necessary, use reducing bushing (A) (Fig. 29).

Series	Wire cross section [mm ²]	With reducing bushing (A)	Stripping length L [mm]
LV80/120	10	Rb-25/10	18
	16	Rb-25/16	
	25	-	
LV160/250	25	Rb-50/25	20
	35	Rb-50/35	
	50	-	
LV320/400	35	Rb-50/35	20
	50	-	
	70	-	
	95	-	25
	AWG 4/0	-	
LV500	AWG 4/0	-	25

2 Crimp the cables at the main contacts

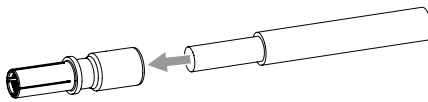

Fig. 30:

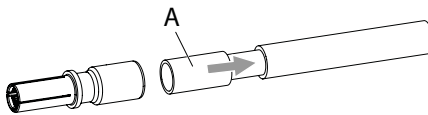

Fig. 31:

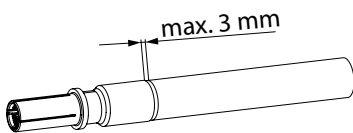

Fig. 32:

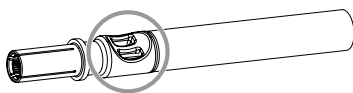

Fig. 33:

Without use of reducing bushings:

1. Push the bare cable braid into the connection area of the contact (Fig. 30).

With use of reducing bushings:

1. Push the reducing bushing (A) as shown in Fig. 31 onto the bare cable braid and push the cable braid together with the reducing bushing into the connection area of the contact.
2. When doing so, ensure that the gap between insulation and contact is not more than 3 mm (Fig. 32).
3. Insert a crimp insert suitable for the wire cross section into the crimp tool (see section "4. Tools").
4. Crimp contact and cable (if necessary including the reducing bushing) as shown in Fig. 33.

3 Fit the heat shrink tube for the main contacts

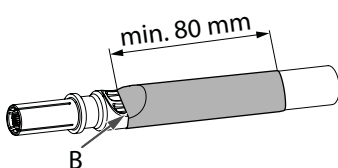

Fig. 34:

1. Cut the heat shrink tube to the required length (at least 80 mm) plus 5-10 % heat shrink tube allowance (Fig. 34). In doing so ensure the cut edges are even.
2. Push the heat shrink tubing onto the cable and contact so that the end is positioned centrally within the crimping area on the contact (Fig. 34/B). Prevent any creasing.
3. Using a heat shrink device, e.g. a hot air gun, heat the heat shrink tubing with up and down movements until the heat shrink tubing lies smoothly without any creases against the contact and cable.

4 Strip the cables for pilot/auxiliary contacts (optional additional component).

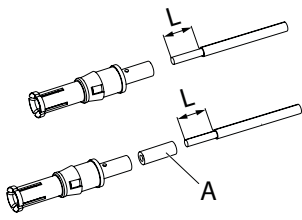

Fig. 35: Pilot contacts

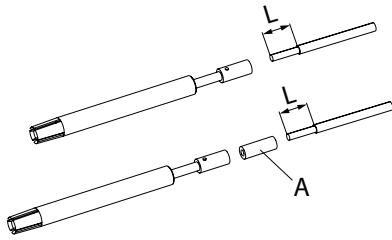

Fig. 36: Auxiliary contacts

- Strip the cables for the pilot/auxiliary contacts to length L as indicated in the table below (Fig. 35 or Fig. 36).
If a reduction of the connection cross section is necessary, use reducing bushing (A) (Fig. 35 or Fig. 36).

Series	Wire cross section [mm ²]	With reducing bushing (A)	Stripping length L [mm]
LV80/120	0.5	Rb-2.5/0.5	7.5
LV160/250	1.0	Rb-2.5/1.0	
LV320/400	1.5	Rb-2.5/1.5	
LV500	2.5	-	

5 Crimp the cables to the pilot/auxiliary contacts (optional additional component).

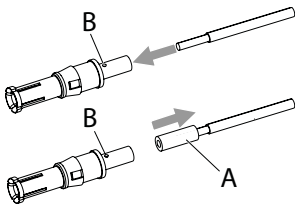

Fig. 37: Pilot contacts

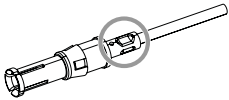

Fig. 38: Pilot contacts

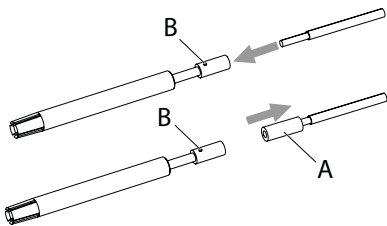

Fig. 39: Auxiliary contacts

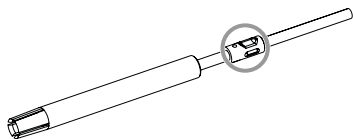

Fig. 40: Auxiliary contacts

Note: For series LV80/120, pilot and auxiliary contacts have the same design.

Without use of reducing sleeves:

- Push the bare cable braid into the connection area of the contact (Fig. 37 or Fig. 39).

With use of reducing bushings:

- Push the reducing bushing (A) as shown in Fig. 37 or Fig. 39 onto the bare cable braid and push the cable braid together with the reducing bushing into the connection area of the contact.
- Push the cable braid (if necessary including the reducing bushing) into the contact until it is visible in the checking hole (Fig. 37/B or Fig. 39/B)
- Crimp contact and cable (if necessary including the reducing bushing) using the crimping tool (see section "4. Tools"), as shown in Fig. 38 or Fig. 40.

2.2 Assembling the battery socket

Tools required

- Crosshead screwdriver PH2 and PH3
- Slotted screwdriver no. 3
- Torque wrench

Assembly steps overview

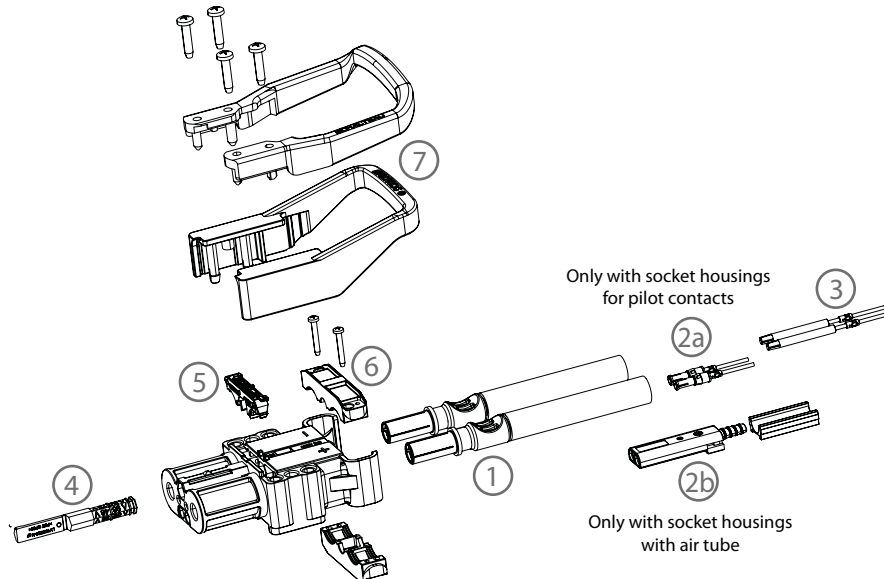

Fig. 41:

The assembly steps ① to ⑦ are described in detail on the following pages.

① Install the main contacts in the battery socket

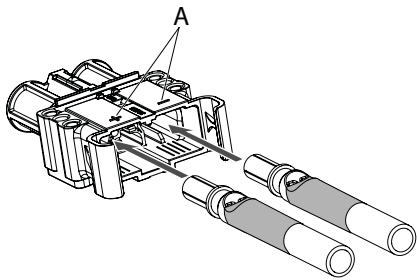

Fig. 42:

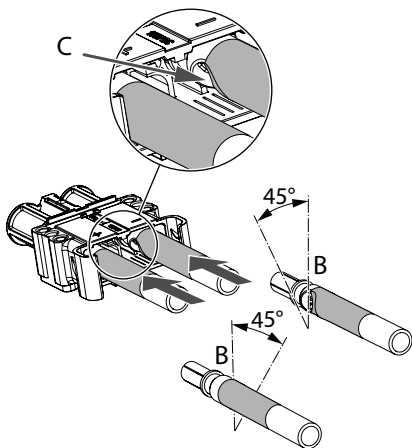

Fig. 43:

⚠ WARNING

An incorrect connection could result in a fatal electric shock. Observe the polarity markings (+) and (-) on the battery socket (Fig. 42/A).

1. Push in the main contacts with crimped cables as far as they will go into the battery socket housing (Fig. 42).

Note: Only applies for contact sizes 95 mm² and AWG 4/0:

1. Turn the crimp area (B) to about 45° from vertical (Fig. 43/B).
2. Push in the main contacts so that the crimping area points downwards at an angle towards the inside of the socket, as shown in (Fig. 43/C).

2a) Install the pilot contacts into the battery socket for pilot contacts (optional additional component)

With socket housings for pilot contacts, the pilot contact adapter is pre-installed in the housing.

Either 2a or 2b

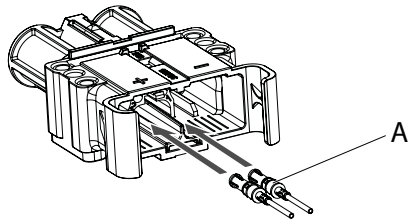

Fig. 44:

1. Push the pilot contacts (*Fig. 44/A*) with the crimped wires into the contact chambers of the pre-installed pilot contact adapter as far as they will go until the retaining clip clicks into place.
2. Pull gently on the wires to check whether the pilot contacts are correctly fixed and the retaining clips are engaged.

Note: For disassembly of pilot contacts, see section "3. Disassembly of pilot and auxiliary contacts".

2b) Install the air tube and spacer in the battery socket with air tube (optional additional component, only for wet-cell battery applications)

For socket housings with an air tube, an air tube with a spacer is supplied separately.

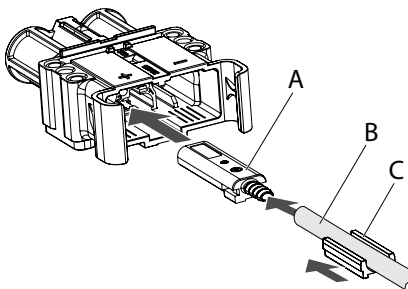

Fig. 45:

Air hose specification

The air hoses for the air tubes must have the following specification:

- Internal Ø 6 mm
- Wall thickness ≤ 1.5 mm
- Shore hardness 73

1. Push the air hose (*Fig. 45/B*) as far as it will go onto the air tube (*Fig. 45/A*).
2. Push the air tube with attached air hose into the socket housing until it clicks audibly into place.
3. After it has clicked into place, check that the air tube is firmly seated by pressing on it against the direction of assembly.
4. Push the spacer (*Fig. 45/C*) flush into the socket housing as far as it will go.

3) Install the auxiliary contacts in the battery socket (optional additional component)

Note: For the LV320/400 and LV500 series, the auxiliary contacts must be installed with the main contacts because the auxiliary contacts and main contacts are fixed together using the slider.

Only for series LV80/120 and LV160/250:

1. Push the auxiliary contacts with the crimped wires into the contact chambers of the socket housing as far as they will go until they click into place.
2. Pull gently on the wires to check whether the auxiliary contacts are correctly fixed and clicked into place.

Only for series LV320/400 and LV500:

1. Push the auxiliary contacts with the crimped wires into the contact chambers of the socket housing as far as they will go.
2. Check whether the contacts are correctly positioned in the guides in the socket housing so that they can be correctly fixed by the slider.

Note: For disassembly of auxiliary contacts, see section "3. Disassembly of pilot and auxiliary contacts".

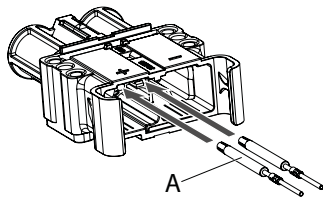

Fig. 46:

4 Install the coding pin in the battery socket (optional additional component)

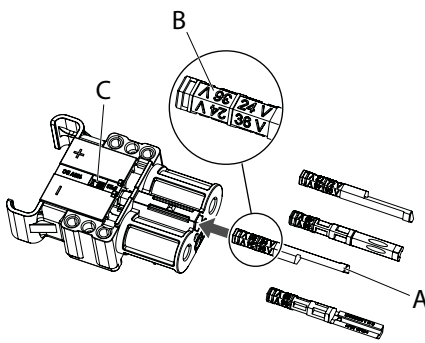

Fig. 47:

1. Rotate the coding pin (Fig. 47/A) for the required voltage so that the voltage indication faces upwards.
 - For battery sockets, the voltage indication on the rear part of the coding pin is defining (Fig. 47/B).
 - After insertion, the voltage indication (B) on the coding pin must be visible in the housing cut-out (Fig. 47/C).
2. Push the coding pin from the front into the coding pin receiver in the socket and press in firmly until it audibly clicks into place.
 - The voltage indication (B) on the coding pin must now be visible in the housing cut-out (C).

If the coding pin has been incorrectly inserted, drive the coding pin out from the back of the socket and insert it again.

5 Install the slider in the battery socket

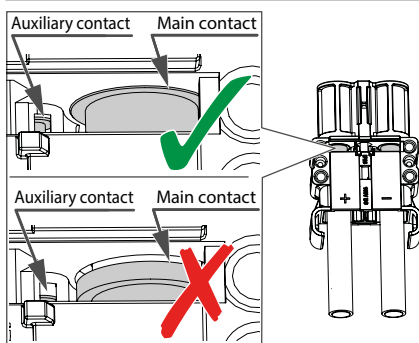

Fig. 48:

Notes:

- For the LV320/400 series, the auxiliary contacts (where used) must be installed with the main contacts because the auxiliary contacts and main contacts are fixed together using the slider.
- For the LV80/120 series, the coding pin for the voltage coding must be fitted before the slider is fitted in place.
- There is no latch on the slider for the LV80/120 series.

1. Ensure that the main contacts and the auxiliary contacts (where used) are correctly positioned in the guides in the housing (Fig. 48).
2. Ensure that the latch on the slider is in the unlocked position (Fig. 49).
 - Latch pushed fully to the right (C).
 - Recess (D) of the latch and bar (E) of the main body are not aligned over each other.
3. Insert the slider into the housing so that when it is unlocked the logo can be read when viewed from the insertion side.
4. Push the slider in on both sides until it audibly clicks into place (Fig. 50).
5. Use a slotted screwdriver to push the latch on the slider as far as it will go (about 4 to 5 mm) into the locked position (Fig. 51/F).
6. Ensure that the latch is in the locked position (Fig. 51).
 - The latch must be pushed fully to the left into position (F)
 - Recess (D) of the latch and bar (E) of the main body must be aligned over each other.
 - Letter "Z" or a lock symbol is visible to the right on the slider (G).

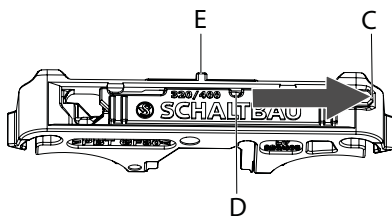

Fig. 49:

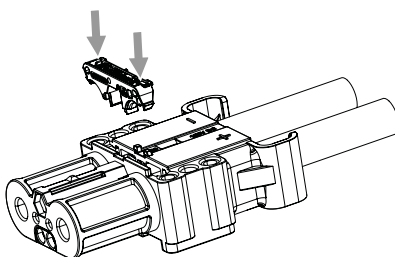

Fig. 50:

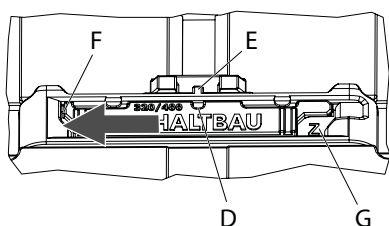
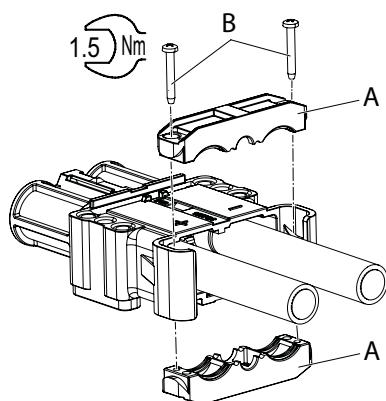

Fig. 51:

6 Install the strain relief in the battery socket



1. Position the upper and lower clamp (*Fig. 52/A*) of the strain relief on the cable.
2. Align the cables of the main contacts (as well as the auxiliary contacts/pilot contacts or air hose, where used).
3. Using a PH2 crosshead screwdriver, uniformly tighten the clamps (A) using both screws (B). In doing so, ensure
 - that both screws (B) are uniformly tightened,
 - that the clamps (A) are not tilted or skewed.
4. Tighten both screws (B) to a torque of 1.5 Nm.
5. Check that all cables are reliably secured against strain/pulling.

Fig. 52:

7 Install the handle on the battery socket (optional additional component)

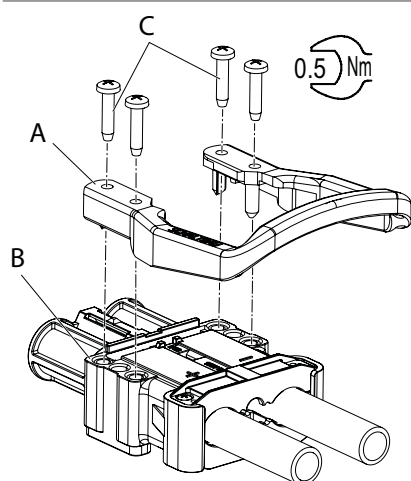

Screw-on handle (*Fig. 53*)

1. Insert the screw-on handle (A) into the provided securing holes on the housing (B).
2. Screw on the handle with a PH3 crosshead screwdriver using the four mounting screws (C).
3. Tighten the four mounting screws to a torque of 0.5 Nm.

Fig. 53: Screw-on handle

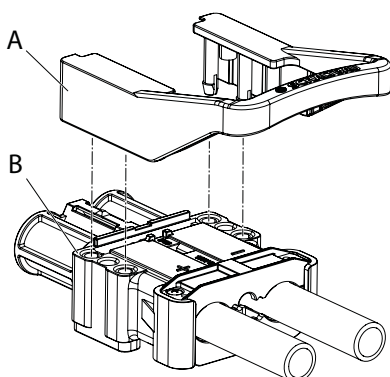

Snap-on handle (*Fig. 54*)

1. Press the snap-on handle (A) into the provided securing holes on the housing (B).

Fig. 54: Snap-on handle

3. Disassembly of pilot and auxiliary contacts

Tools required

- Extraction tools (see section "4. Tools")

1

Disassemble pilot and auxiliary contacts

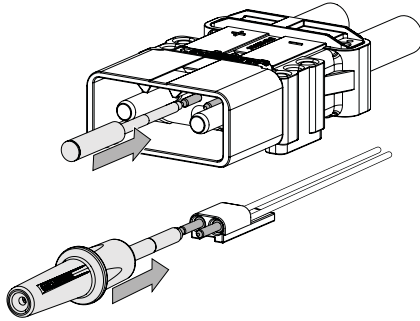

Fig. 55:

Note: Here disassembly of pilot and auxiliary contacts is illustrated using the example of a charger/vehicle plug. Disassembly for a battery socket takes place in the same way.

1. Insert the appropriate extraction tool (see section "4. Tools") over the contact as far as it will go. This unlocks the retaining clip used to secure the contact.
2. Press the contacts backwards out of the contact chambers as shown in **Fig. 55**.
 - With the extraction tools LV80/120-ET-Pc/Ac and LV160/250-ET-Ac the pressing out is performed by a plunger.
 - With the extraction tool ETC-C/H the pressing out is performed by a sprung plunger.
3. Pull the contacts completely out of the housing by pulling gently on the cable.

4. Tools

4.1 Crimping tools



Fig. 56:

CTH-U/≤300

Hydraulic crimping tool without crimp inserts, for main contacts
Item no. 1-1440-357320



Fig. 57:

CTE-U/≤400

Electrical crimping tool, without crimp inserts, for main contacts
Item no. 1-1440-355163



Fig. 58:

CTM-H/≤6.00

Crimping tool for pilot/auxiliary contacts,
for wire cross sections 0.5 / 1.0 / 1.5 / 2.5 mm²
Item no. 1-1440-339551

The holders for the crimp inserts for crimping tools CTH-U/≤300 and CTE-U/≤400 are standardised for 130 kN. In this way, other crimp inserts/crimp formers can be used so that the crimping tools can be used universally.

4.2 Crimp insert sets for CTH-U/≤300 and CTE-U/≤400 for main contacts

Series	Wire cross section main contacts [mm ²]	With reducing bushing	1x set crimp insert, ordering code	Item no.	Figure
LV80/120	10	Rb-25/10	CID-W-25/S	1-1440-354253	
	16	Rb-25/16			
	25	-			
LV160/250	25	Rb-50/25	CID-W-50/S	1-1440-354255	
	35	Rb-50/35			
	50	-			
LV320/400	35	Rb-50/35	CID-W-70/S	1-1440-354256	
	50	-			
	70	-			
LV500	95	-	CID-W-95/S	1-1440-354258	
	AWG 4/0	-	CID-W-4/0/S	1-1440-354259	
	AWG 4/0	-	CID-W-4/0/S		

4.3 Extraction tools for pilot and auxiliary contacts

Special extraction tools are necessary for disassembly of pilot and auxiliary contacts. The extraction tools are suitable for pin contacts (for charger and vehicle plugs) as well as for socket contacts (for battery sockets).

You can determine the correct extraction tool for the series using the following table.

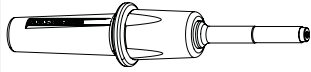
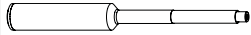
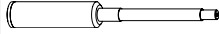
Extraction tools, ordering code	Item no.	Description	Series				Figure
			LV80/120	LV160/250	LV320/400	LV500	
ETC-C/H	1-1440-267598	Extraction tool for pilot contacts	---	●	●	●	
LV160/250-ET-Ac	1-1448-151481	Extraction tool for auxiliary contacts	---	●	--- ¹⁾	--- ¹⁾	
LV80/120-ET-Pc/Ac	1-1448-135003	Extraction tool for pilot and auxiliary contacts	●	---	---	---	

¹⁾ For series LV320/400 and LV500, the auxiliary contacts are locked using the slider.

Schaltbau GmbH

For detailed information on our products and services visit our website – or give us a call!

Schaltbau GmbH
Hollerithstrasse 5
81829 Munich
Germany



Phone +49 89 9 30 05-0
Fax +49 89 9 30 05-350
Internet www.schaltbau.com
e-Mail contact@schaltbau.de

with compliments:



The production facilities of Schaltbau GmbH have been IRIS certified since 2008.



Certified to DIN EN ISO 14001 since 2002. For the most recent certificate visit our website.



Certified to DIN EN ISO 9001 since 1994. For the most recent certificate visit our website.

Electrical Components and Systems for Railway Engineering and Industrial Applications

Connectors

- Connectors manufactured to industry standards
- Connectors to suit the special requirements of communications engineering (MIL connectors)
- Charging connectors for battery-powered machines and systems
- Connectors for railway engineering, including UIC connectors
- Special connectors to suit customer requirements

Snap-action switches

- Snap-action switches with positive opening operation
- Snap-action switches with self-cleaning contacts
- Snap-action switch made of robust polyetherimide (PEI)
- Snap-action switch with two galvanically isolated contact bridges
- Special switches to suit customer requirements

Contactors Emergency disconnect switches

- Single and multi-pole DC contactors
- High-voltage AC/DC contactors
- Contactors for battery powered vehicles and power supplies
- Contactors for railway applications
- Terminal bolts and fuse holders
- DC emergency disconnect switches
- Special contactors to suit customer requirements

Electrics for rolling stock

- Equipment for driver's cab
- Equipment for passenger use
- High-voltage switchgear
- High-voltage heaters
- High-voltage roof equipment
- Equipment for electric brakes
- Design and engineering of train electrics to customer requirements