

# 3

## Contactors

C193, C294 series

Single- and double pole  
NO contactors

Installation and maintenance  
instructions

Manual B193-B294-M.en

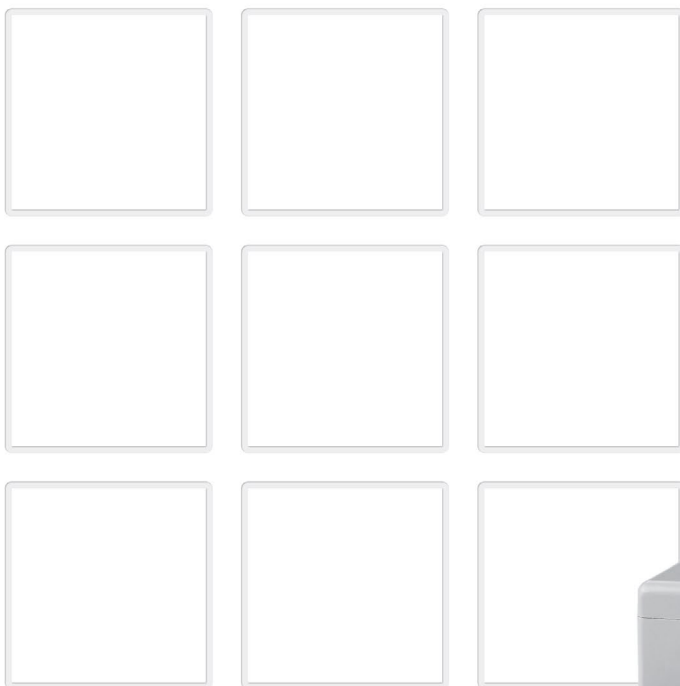

**Document Revision History**

Date	Rev. Level	Description	Pages
2019-08-07	1.0	First release	all
2023-03-16	2.0	Mounting positions modified	13

## Content

<b>1. Important basic information</b>	<b>4</b>
1.1 Legal notes	4
1.2 Conventions for this manual	4
<b>2. General and security information</b>	<b>4</b>
2.1 Observing the instructions	4
2.2 User obligations	5
2.3 Intended use	5
2.4 Ambient conditions	5
<b>3. Dangers and security measures</b>	<b>6</b>
3.1 Electrical dangers	6
3.2 Other dangers	6
3.3 Measures for avoiding damages and malfunctions	7
<b>4. Product information</b>	<b>8</b>
4.1 Contactors of the C193 and C294 series	8
4.2 Special features	8
4.3 Applications	8
4.4 Technical information and material specification	8
4.5 Survey of the C193 and C294 series (stock items)	9
C193 series (single pole NO contactors)	9
C294 series (double pole NO contactors)	10
<b>5. Storage</b>	<b>11</b>
<b>6. Unpacking</b>	<b>11</b>
6.1 Unpack the device	11
6.2 Check parts for transport damage	11

<b>7. Installation .....</b>	<b>12</b>
7.1 Mechanical installation .....	12
Dimensions and further technical specifications .....	12
Preliminaries .....	12
Correct mounting positions .....	13
Required minimum clearance .....	13
Ventilation requirements .....	14
Safety .....	14
Required tools and auxiliaries .....	14
Install the contactor .....	14
DIN rail mounting (only C193 series) .....	15
7.2 Electrical installation .....	15
Electrical data and further technical specifications .....	15
Preliminaries .....	15
Safety .....	16
Required tools and auxiliaries .....	16
Connect the auxiliary contact .....	17
Connect the coil terminals .....	18
Connect the main contacts .....	19
7.3 Checks .....	21
<b>8. Maintenance .....</b>	<b>22</b>
8.1 Safety .....	22
8.2 Preventive maintenance .....	22
Intervals for regular checks .....	22
Regular check activities .....	23
8.3 Corrective maintenance .....	24
Replace the auxiliary contact .....	24
<b>9. Spare parts .....</b>	<b>25</b>
<b>10. Technical data .....</b>	<b>25</b>
<b>11. Disposal .....</b>	<b>25</b>

# 1. Important basic information

## 1.1 Legal notes

Without prior written consent of Schaltbau GmbH, this manual is not allowed to be electronically or mechanically reproduced – as a whole or in parts – be distributed, changed, transmitted, translated into another language or used in any other way.

Schaltbau GmbH cannot be held liable for damage caused by not observing (or only partly observing) the manual.

## 1.2 Conventions for this manual

This manual describes the installation and maintenance of the contactors.

Cross references are presented in bold italics.

To highlight particularly important safety instructions and other information, the following symbols are used in this instructions:

### **DANGER**

Indicates a hazardous situation with a high level of risk which, if not avoided, will result in death or serious injury.

### **WARNING**

Indicates a hazardous situation with a medium level of risk which, if not avoided, could result in death or serious injury.

### **CAUTION**

Indicates a hazardous situation with a low level of risk which, if not avoided, may result in minor or moderate injury.

### **NOTICE**

Indicates a hazardous situation which, if not avoided, may result in property damage, such as service interruption or damage to equipment or other materials.



Refers to technical features and methods aimed at facilitating work or to particularly important information.

This manual refers to NO contactors of the following-types:

- C193 (single pole), C294 (double pole).
- This manual describes only stock items of the above mentioned contactor types. If you need a special variant feel free to contact us.

# 2. General and security information

The contactors dealt with in this document are intended for use with high-voltage systems for special installations. They are designed and tested in compliance with the generally recognised state of the art. However, improper use, operation, handling, maintenance or tampering with electric equipment can cause serious or fatal injury to the user or others, and the appliance or other property can be damaged.

The operation, maintenance and installation instructions for the contactors must therefore be strictly followed.

Any uncertainties must be clarified and all queries must include details of the type of device and the serial number.

Only authorized and trained personnel are allowed to plan and carry out all mechanical and electrical installations, transport, commissioning, as well as maintenance and repair work. This applies to the observation of the

general installation and safety regulations for high-voltage systems as well as the proper use of tools approved for this purpose. Electric equipment requires protection from moisture and dust during installation and storage.

## 2.1 Observing the instructions

- ▶ All staff must read and understand the instructions in this manual and adhere to them when working with the device.
- ▶ **Always carefully observe all safety warnings!**

## 2.2 User obligations

- ▶ Observe all applicable national provisions, all safety, accident prevention and environmental regulations as well as the recognized technical rules for safe and proper working.
- ▶ Carry out regular inspections of all protection and safety devices to see if they work properly.
- ▶ Work on electric equipment may only be performed by an expert or trained personnel working under the direction and supervision of an expert according to the applicable rules of electrical engineering.
- ▶ An expert is a person who can judge and recognise the possible dangers of the jobs commended to him based on his training, knowledge and experience and by knowledge of the appropriate regulations.
- ▶ Work on the contactors must only be carried out by staff who meets the requirements set out in this manual.
- ▶ Staff must be informed clearly about who is responsible for the maintenance of the contactors.
- ▶ After each installation work and/or after any other modifications, alterations or maintenance works, always perform complete checks according to these standards:
  - IEC 60077-2
  - IEC 60947-4-1

## 2.3 Intended use

- ▶ The contactors have been designed and tested according to national and international standards. Due to their unique features they can also be used in a variety of applications.
- ▶ The contactors must only be used under operating conditions according to the technical specification and the instructions in this manual.
- ▶ None of the operating conditions defined in the corresponding data sheets and in our *catalogues B193* and *B294* in section "**Specifications**", such as voltages, currents, ambient conditions, etc. may be changed. The *catalogues* are available under: <https://www.schaltbau.com/en/media-library/>
- ▶ The contactors may only be used when all protective devices are present, have been installed properly and are fully operational.
- ▶ Contactors may not be used without further protective measures in potentially explosive atmospheres and/or in aggressive media.

- ▶ Coil suppression for reducing surges when the coil is switched off is optimally attuned to the contactor's switching behaviour. The existing opening characteristic must not be negatively influenced by parallel connection with an external diode.
- ▶ Do not use the contactor without properly mounted arc chute cover.
- ▶ The contactor has unprotected live parts
- ▶ The required clearance of live parts to earth and other parts of the contactor is to be observed as well as the safety regulations of the applicable standards.
- ▶ Switching at maximum breaking capacity might require larger clearance! Do not hesitate to ask our advice for dimensioning.
- ▶ Improper handling of the contactors, e.g. when hitting the floor with some impact, can result in breakage, cracks and deformation. Always handle the contactors with care.
- ▶ Use the contactor only according to its intended use. Replace or repair damaged parts exclusively with original parts. Any other usage of or tampering with the contactors is considered contrary to its intended use. No liability is assumed for damages and accidents caused due to non-compliance with the instructions in this manual or improper use of the contactors.

## 2.4 Ambient conditions

### NOTICE

The contactors are constructed for specific ambient conditions.

- ▶ Operate the contactors only according to the ambient conditions, like temperature ranges, pollution degree, etc., as defined in the corresponding data sheets and in our *catalogues B193* and *B294*. The *catalogues* are available under:

<https://www.schaltbau.com/en/media-library/>

## 3. Dangers and security measures

### 3.1 Electrical dangers

	<p><b>⚠ DANGER</b></p>
	<p>The contactors are used to switch voltage. The touching of electrically conducting parts may result in serious injuries or even death!</p> <p>Energized parts are all metal parts belonging directly to one of the circuits or wires leading there. All other visible metal parts and wires may also be energized in the case of a failure.</p> <p>Before beginning any work on the contactors, always observe the following safety regulations:</p> <ul style="list-style-type: none"> <li>▶ Disconnect on all sides</li> <li>▶ Ensure that it is not possible to reconnect unintentionally</li> <li>▶ Clearly mark your work area</li> <li>▶ Make sure that there is no voltage present</li> <li>▶ Earth and short circuit the installation; this also includes the discharging of any capacitors in the main circuit</li> <li>▶ Besides the main electric circuit, also disconnect additional and auxiliary circuits</li> <li>▶ Cover or insulate adjacent energized parts</li> <li>▶ Only an electrically skilled person may determine if there is no voltage present</li> <li>▶ When the work has been concluded, proceed the other way round.</li> </ul>

### 3.2 Other dangers

	<p><b>⚠ WARNING</b></p>
	<p>Exclusively use the contactors for purposes as indicated in the specifications and data sheets. A wrong application can cause accidents and severe damages to persons!</p> <ul style="list-style-type: none"> <li>▶ The manufacturer doesn't take the responsibility for accidents which were caused by improper use of the product.</li> </ul>

	<p><b>⚠ CAUTION</b></p>
	<p>During continuous operation the contactors may become hot. Risk of burns!</p> <ul style="list-style-type: none"> <li>▶ Before beginning any checks or maintenance work on the contactors make sure that the heated components have cooled down.</li> </ul>

	<p><b>⚠ CAUTION</b></p>
	<p>The contactors contain sharp-edged parts. Risk of injury!</p> <ul style="list-style-type: none"> <li>▶ Use appropriate tools for installation and maintenance works on the contactors.</li> <li>▶ Wear protective gloves when working with sharp-edged components.</li> </ul>

### 3.3 Measures for avoiding damages and malfunctions

#### NOTICE

Aggressive fluids may damage the contactors.

- ▶ Make sure that the contactors are not exposed to aggressive fluids.

#### NOTICE

Improper handling of the contactors, e.g. when hitting the floor with some impact, can result in breakage, cracks and deformation.

- ▶ Make sure that the contactors are always used properly.
- ▶ Do not throw the contactors to the floor.
- ▶ Regularly sight-check the contactors for potential damages.
- ▶ Immediately replace damaged components.

#### NOTICE

Depending on the product type, contactors can contain strong (permanent) magnets. These magnets can attract ferromagnetic particles and may damage the contactors.

- ▶ Make sure that the contactors are installed at a location, where no ferromagnetic particles can be attracted.

#### NOTICE

Depending on the product type, contactors can contain strong (permanent) magnets. These magnets can destroy data on credit cards or similar cards.

- ▶ Keep credit cards or similar cards away from the contactors..

#### NOTICE

During the switching off, strong electromagnetic fields are generated in the surroundings of the contactors. These may influence other components close to the contactors.

- ▶ Make sure that the contactors are installed at a location, where no other components can be affected.

#### NOTICE

In the case of damage, wear and tear and/or soiling of the contactor components - in the form of a partial break, sharp edges and discoloured surfaces - the functional safety of the contactors is no longer guaranteed.

- ▶ Carry out regular visual checks to detect wear and tear and dirt.
- ▶ Immediately replace damaged parts.
- ▶ Immediately remove dirt without leaving any residues.
- ▶ Immediately replace parts with stubborn dirt.

#### NOTICE

Detent-edged rings and detent-edged washers have a limited life time. After 3 times opening of screws secured with detent-edged rings or detent-edged washers, the rings or washers must be replaced by new ones.

- ▶ Record the frequency of screw opening in the work log.
- ▶ After 3 times opening of screws, replace detent-edged rings or detent-edged washers by new ones..

## 4. Product information

### 4.1 Contactors of the C193 and C294 series

#### Single and double pole high-voltage contactors of compact design:

Notwithstanding its small size, the contactors feature an extraordinary switching capacity.

The C193 series contactor is suitable for DC applications up to 1,000 V.

The C294 series contactor is suitable for DC applications up to 1,000 V per contact system or 1,500 V when main contacts connected in series.

Best suited for the harsh environment of public transport, both contactor series have been proven to be transportation system components of high reliability which have an electrical life that is above average.

### 4.2 Special features

- ▶ Suitable for years of continuous duty
- ▶ Intended for high ambient temperatures
- ▶ Compact design
- ▶ Double-break contacts
- ▶ DC versions with blowout magnets for arc quenching
- ▶ Only for C193 series:
  - Versions for AC and DC operation available
  - DIN rail mount option

### 4.3 Applications

Typical applications are to be found in traffic engineering equipment, particularly in heating circuits, air conditioning equipment and conversion engineering of complex power supplies.

### 4.4 Technical information and material specification

For technical information and material specifications, refer to the corresponding data sheets and to our *catalogues B193 and B294*.

The *catalogues* are available under:

<https://www.schaltbau.com/en/media-library/>



## 4.5 Survey of the C193 and C294 series (stock items)

### C193 series (single pole NO contactors)

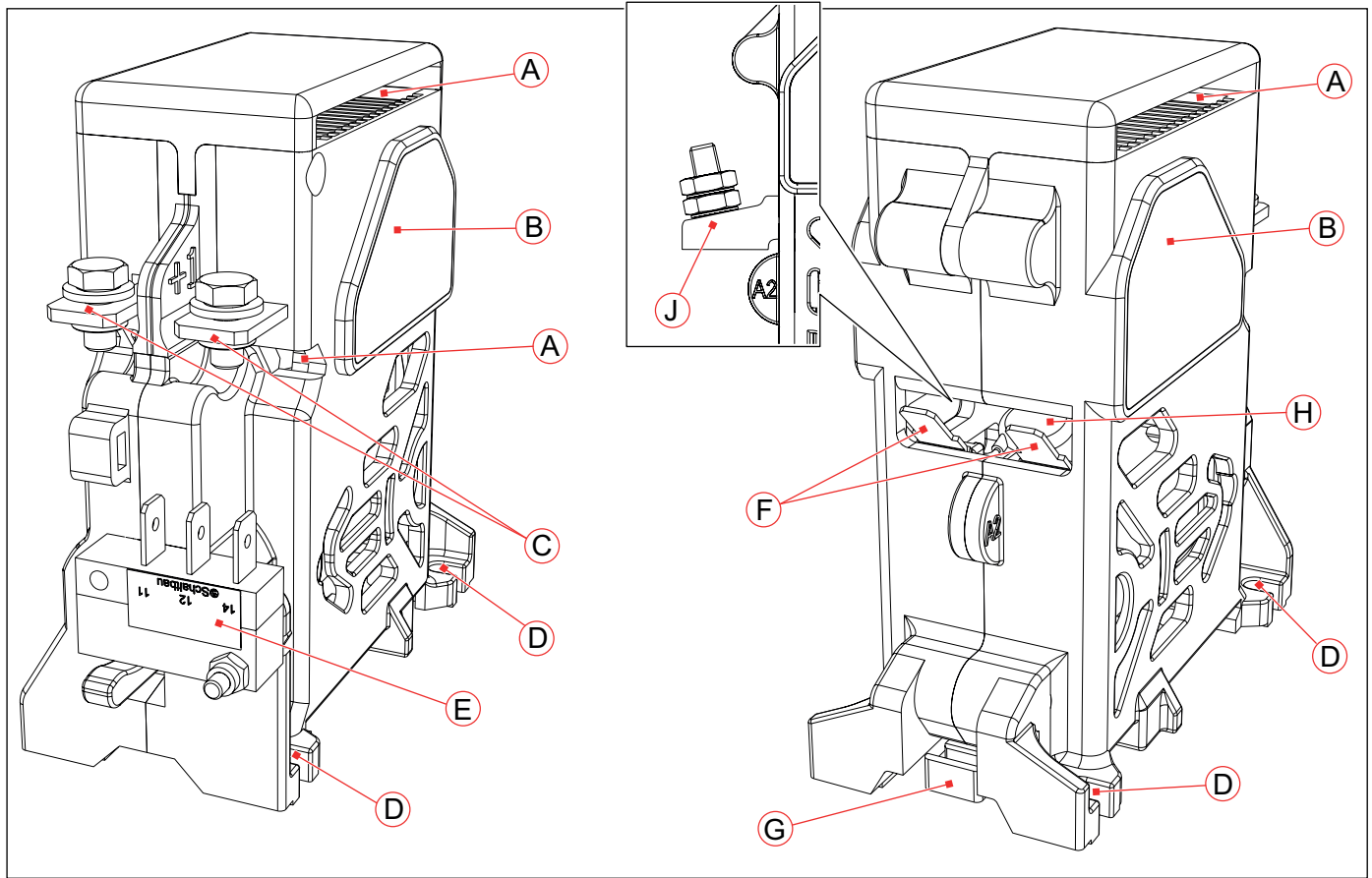

Fig. 1: C193 series (left: front view, right: rear view)

- A Plasma exits
- B Permanent magnets (behind cover)
- C Main contacts, terminals hexagon head bolts M5 + load washers, tightening torque: 3 Nm max.  
Alternative version: main contact terminals with hexagon head bolts, inch thread 10-24UNC x 3/8" + load washers
- D Mounting holes for screws M4, Tightening torque: 2 Nm max.
- E Auxiliary contact (S870), Terminals: Flat tabs 6.3 x 0.8 mm
- F Coil terminals A1 and A2, Flat tabs 6.3 x 0.8 mm
- G Slider for DIN rail mounting (DIN rail 35 mm)
- H Varistor (suppressor diode optional)
- J Alternative version: Coil terminals with hexagon head bolts, inch thread 10-24UNC x 5/8", each with 2 hexagon nuts 10-24UNC + load washers

## C294 series (double pole NO contactors)

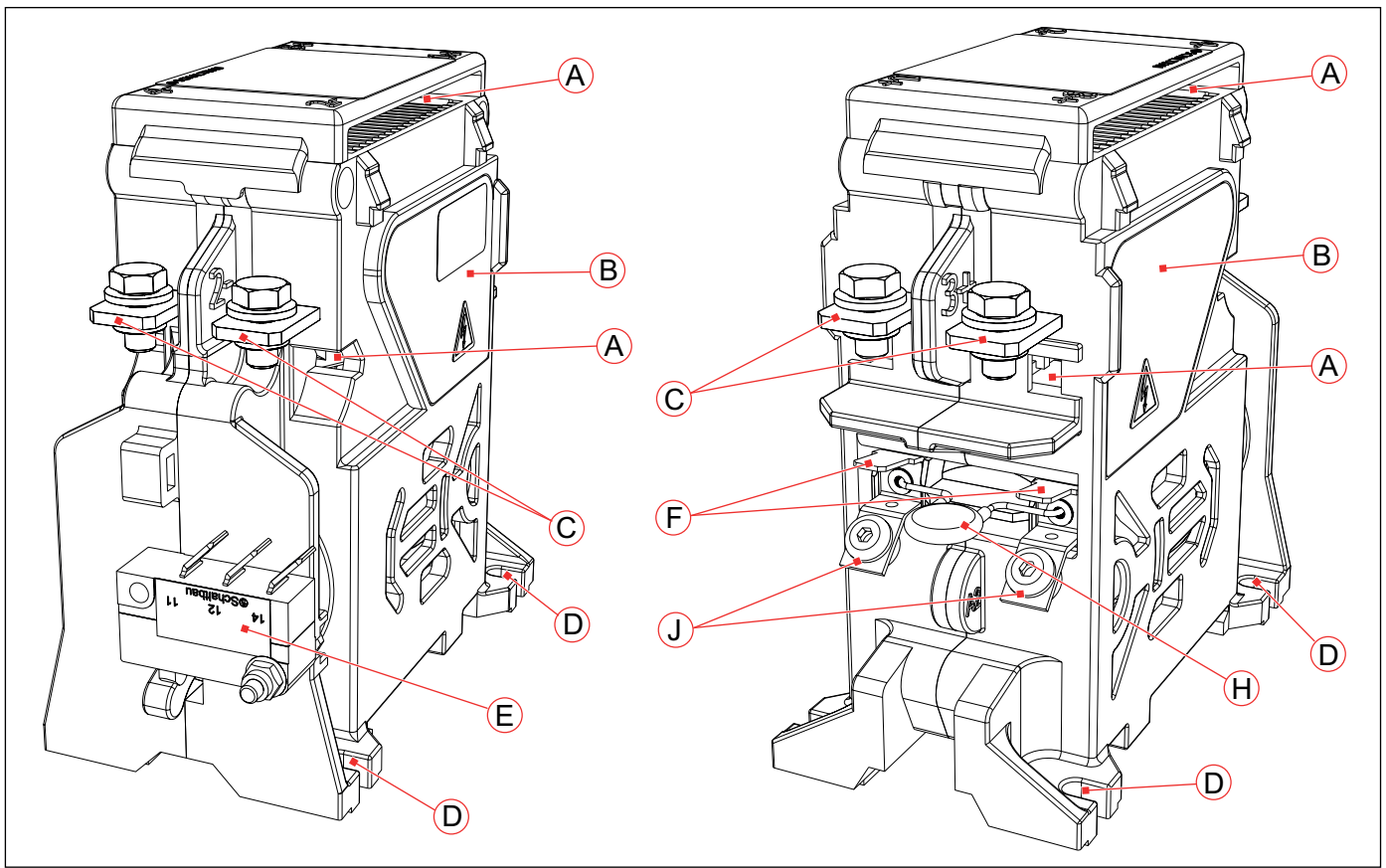

Fig. 2: C294 series (left: front view, right: rear view)

- A Plasma exits
- B Permanent magnets (behind cover)
- C Main contacts, terminals hexagon head bolts M5  
+ load washers, tightening torque: 3 Nm max.  
Alternative version: main contact terminals with hexagon  
head bolts, inch thread 10-24UNC x 3/8" + load washers
- D Mounting holes for screws M4,  
Tightening torque: 2 Nm max.
- E Auxiliary contact (S870), Terminals: Flat tabs 6.3 x 0.8 mm
- F Coil terminals A1 and A2, Flat tabs 6.3 x 0.8 mm
- H Varistor
- J Alternative version: Coil terminals with phillips screws, inch  
thread 8-32UNC x 1/4" + lock washers

## 5. Storage

### NOTICE

Moisture and dust can damage the contactor. If the device is to be stored for a prolonged period of time,

- ▶ store it in its original packaging,
- ▶ store it in a dry and dust-free location.

### Return shipments

Schaltbau recommends to keep the original packing box for any return shipments. If no original packing box is available care must be taken to pack the contactor in a way that prevents damage during shipment.

## 6. Unpacking

### 6.1 Unpack the device

- ▶ Before opening the packaging, perform a visual inspection for any signs that could indicate damage having occurred during transport (impacts, bumps, falling etc.).
- ▶ If any signs indicate that the contactor has been subject to excessive shock influence do not install the contactor.

### 6.2 Check parts for transport damage

### NOTICE

If parts are damaged, the functional reliability of the contactor is no longer given.

- ▶ Before installing, check all parts for any possible transport damage.
- ▶ Do not install a damaged contactor.

## 7. Installation

### 7.1 Mechanical installation

#### Dimensions and further technical specifications

The dimensions and further technical specifications are given in the respective data sheets or in our catalogues. Refer to our *catalogues B193 and B294*.

The *catalogues* are available under:

<https://www.schaltbau.com/en/media-library/>

#### Preliminaries

- ▶ For the fastening of the contactors an appropriate mounting plate with 4 mounting holes according to *Fig. 3* or *Fig. 4* has to be provided.

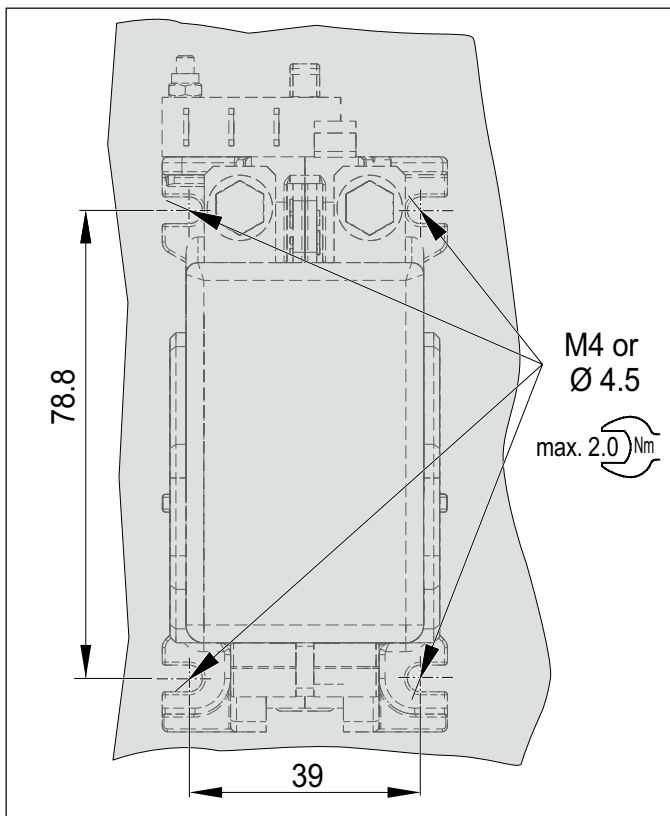

Fig. 3: C193 series: Dimensions (in mm) and arrangement of the mounting holes

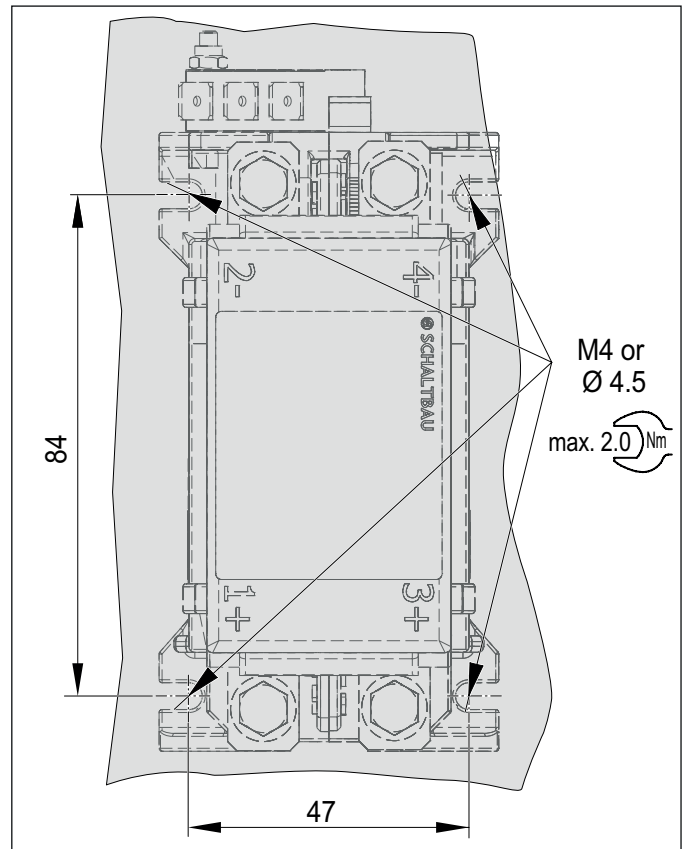

Fig. 4: C294 series: Dimensions (in mm) and arrangement of the mounting holes

- ▶ The mounting holes can either be
  - threaded holes (for threaded screws)
  - or through holes (for threaded screws and nuts).
- ▶ The length of the fixing screws has to be determined according to the constructional conditions.
- ▶ In order to secure the mounting screws against self-loosening, appropriate screw locking elements have to be provided. Schaltbau strongly recommends Schnorr-Washers (or similar) to secure the screws.
- ▶ As an alternative, contactors of the C193 series can also be installed by means of DIN rail mounting. See section **“DIN rail mounting (only C193 series)”**.

### Correct mounting positions

The contactors are designed for horizontal or vertical mounting positions.

Examples for intended mounting positions are shown in *Fig. 5/(A)* and *Fig. 6/(A)*.

The following mounting positions are not permissible:

- for the C294 series: do not mount upside down, so that mounting plate points upwards or coil terminals point downwards as shown in *Fig. 5/(B)*.
- for the C193 series: do not mount upside down, so that mounting plate points upwards as shown in *Fig. 6/(B)*

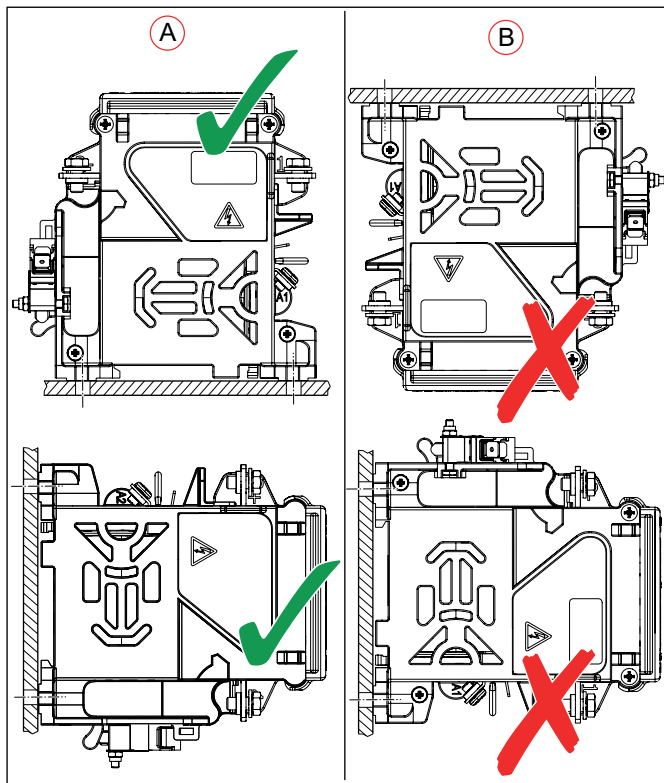

Fig. 5: C294 series - examples for intended mounting positions (A) and non-permissible mounting positions (B)

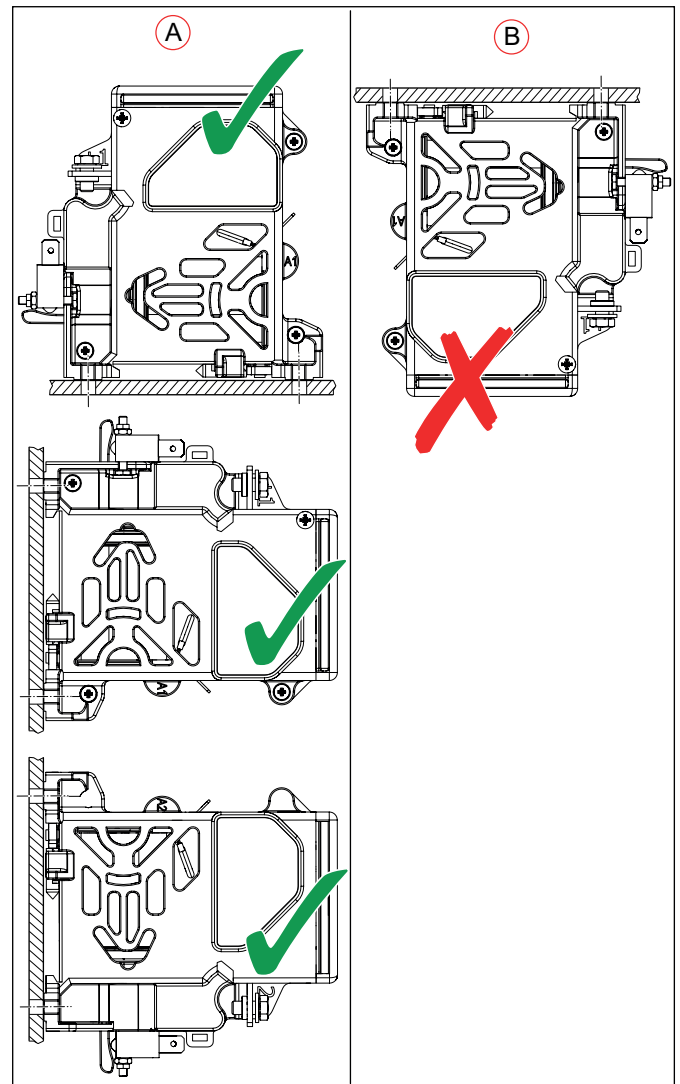

Fig. 6: C193 series - examples for intended mounting positions (A) and non-permissible mounting positions (B)

### Required minimum clearance

#### NOTICE

Switching electrical currents at high voltages will produce arcing and plasma may exit out of the arc chute. It is essential to observe the minimum clearance towards earthed and live parts to avoid the risk of a flash-over.

- ▶ Observe the minimum clearance towards earthed and live parts to plasma exits! Refer to the dimension drawings in our *catalogues B193* and *B294* for minimum clearance upwards and to all sides. The *catalogues* are available under: <https://www.schaltbau.com/en/media-library/>

## Ventilation requirements

- ▶ Ensure sufficient ventilation, especially in the case of heavy arc switching. Allow the exchange of surrounding atmosphere to avoid the risk of flashovers and excessive corrosion.

## Safety

- ▶ The installation has to be carried out by qualified trained personnel.

### NOTICE

During installation, ensure that dirt caused by surrounding construction activities does not get into the contactor.

### NOTICE

Detent-edged rings and detent-edged washers have a limited life time. After 3 times opening of screws secured with detent-edged rings or detent-edged washers, the rings or washers must be replaced by new ones.

- ▶ Record the frequency of screw opening in the work log.
- ▶ After 3 times opening of screws, replace detent-edged rings or detent-edged washers by new ones.

## Required tools and auxiliaries

- Socket wrench set, hexagon nuts
- Hexagon socket wrench set
- Torque wrench

## Install the contactor

- ▶ Make sure, that the mounting surfaces of mounting plate (5) and contactor (3) are free from dirt and other contamination (e. g. metal cuttings).
- ▶ Place the contactor (3) on the mounting plate (5) with the prepared mounting holes.
- ▶ Screw the contactor (3) with four screws (4) on the mounting plate (5).
  - When using threaded holes: Screw the screws with appropriate screw locking elements directly in the threaded holes.
  - When using through holes: Fasten the screws with appropriate screw locking elements and nuts.
- ▶ Then tighten the four screws (4) with the required torque of 2 Nm max.

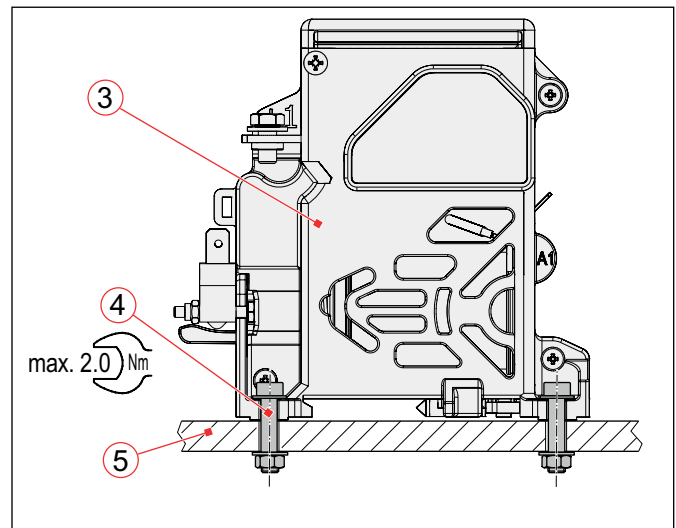

Fig. 7: Install the contactor to the mounting plate (the figure shows the C193 series, the procedure for the C294 series is the same)

### DIN rail mounting (only C193 series)

As an alternative, contactors of the C193 series can also be installed by means of DIN rail mounting. The contactors are prepared accordingly and can be attached and removed to 35 mm DIN rails by using the slider at the bottom of the contactor.

- ▶ Pull and hold the DIN rail slider (8).
- ▶ Attach the contactor with the clamping groove (6) to the DIN rail (7) or slide it laterally to the rail.
- ▶ Press on the contactor gently and release the DIN rail slider (8).
- ▶ Check if the contactor is firmly locked to the DIN rail (7).

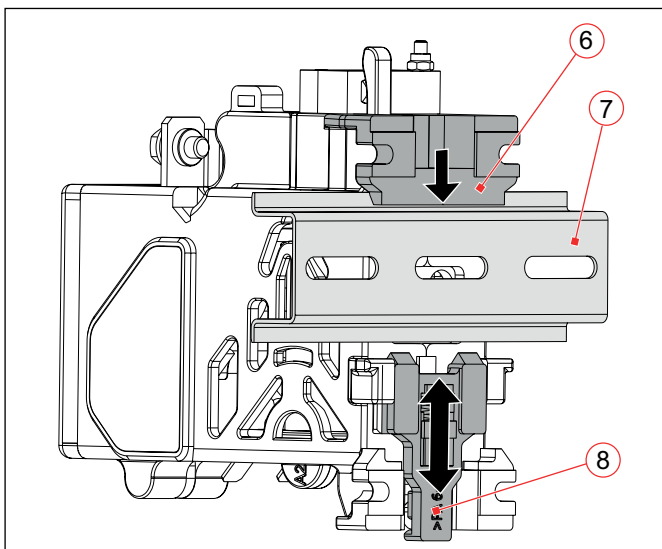

Fig. 8: DIN rail mounting (only C193 series)

## 7.2 Electrical installation

### Electrical data and further technical specifications

For the power consumption of the magnetic drive system and electrical data of the auxiliary switches refer to the respective data sheets and to our *catalogues B193* and *B294*.

The *catalogues* are available under:

<https://www.schaltbau.com/en/media-library/>

### Preliminaries

- ▶ The connection of the main current circuit can be done with wires or busbars.
- ▶ If wires are used, the wire gauges must be selected in coordination with their insulation class and the operating conditions.
- ▶ The minimum gauges of the wires/busbars must be observed. For the required cross sections of wires/busbars refer to our catalogues *B193* and *B294*.  
The *catalogues* are available under:  
<https://www.schaltbau.com/en/media-library/>
- ▶ The wires of the main current circuit must be fitted with appropriate ring cable lugs (for terminal screws M5).
- ▶ The main contact terminals are provided with press nuts M5.
- ▶ Schaltbau recommends Schnorr-Washers (or similar) to secure the terminal screws against self-loosening.  
The terminal screws must be tightened with the required torque of max. 3 Nm.
- ▶ The terminals of the coil and the auxiliary contact are designed as flat tabs. Therefore the control wires must be fitted with appropriate flat receptacles for tabs. Depending on the series, the table shows the type of flat receptacles.

Series	Auxiliary contact terminals: flat receptacles for tabs	Coil terminals: flat receptacles for tabs
C193	6.3 x 0.8 mm	
C294	6.3 x 0.8 mm	

- ▶ The maximum permissible cross section of the auxiliary contact control cables is 1 mm<sup>2</sup>/AWG 18 stranded wire.

## Safety

<b>⚠ DANGER</b>	
	<p>The contactors are used to switch voltage. The touching of electrically conducting parts may result in serious injuries or even death!</p> <p>Energized parts are all metal parts belonging directly to one of the circuits or wires leading there. All other visible metal parts and wires may also be energized in the case of a failure.</p> <p>Before beginning any work on the contactors, always observe the following safety regulations:</p> <ul style="list-style-type: none"><li>▶ Disconnect on all sides</li><li>▶ Ensure that it is not possible to reconnect unintentionally</li><li>▶ Clearly mark your work area</li><li>▶ Make sure that there is no voltage present</li><li>▶ Earth and short circuit the installation; this also includes the discharging of any capacitors in the main circuit</li><li>▶ Besides the main electric circuit, also disconnect additional and auxiliary circuits</li><li>▶ Cover or insulate adjacent energized parts</li><li>▶ Only an electrically skilled person may determine if there is no voltage present</li><li>▶ When the work has been concluded, proceed the other way round.</li></ul>

## NOTICE

Detent-edged rings and detent-edged washers have a limited life time. After 3 times opening of screws secured with detent-edged rings or detent-edged washers, the rings or washers must be replaced by new ones.

- ▶ Record the frequency of screw opening in the work log.
- ▶ After 3 times opening of screws, replace detent-edged rings or detent-edged washers by new ones.

## Required tools and auxiliaries

- Socket wrench set, hexagon nuts
- Open-end wrench set
- Torque wrench
- Continuity tester
- Cable ties



### Connect the auxiliary contact

The control wires for the auxiliary contact must be fitted with appropriate flat receptacles (6.3 x 0.8 mm).

#### NOTICE

- ▶ The maximum permissible cross section of the auxiliary contact control wires is 1 mm<sup>2</sup> / AWG 18 stranded wire.
  - ▶ Bending of the auxiliary contact terminals is not permissible!
  - ▶ Move and lay the control wires and flat receptacles only in plugging direction, see *Fig. 9* and *Fig. 10*.
  - ▶ Attach the control wires mechanically, in order to minimize retroactivities (e. g. shock, vibrations) from the wires to the terminals.
- ▶ Plug the prepared control wires with the flat receptacles (1) to the terminals (2) of the auxiliary contact.
  - ▶ Bundle the control wires with cable ties and fix them to the grommet (3) provided for this purpose.

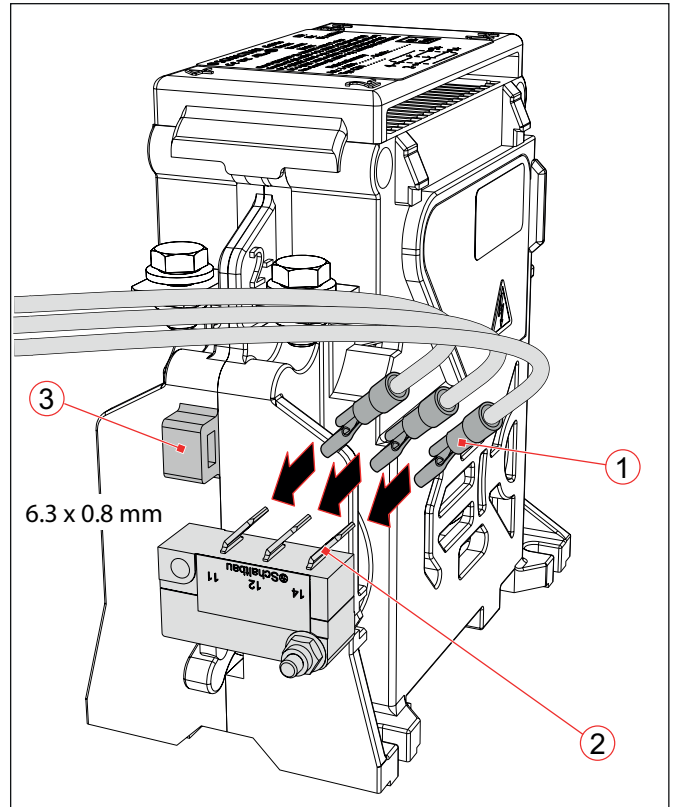

Fig. 10: C294 series: Connect the auxiliary contact (S870)

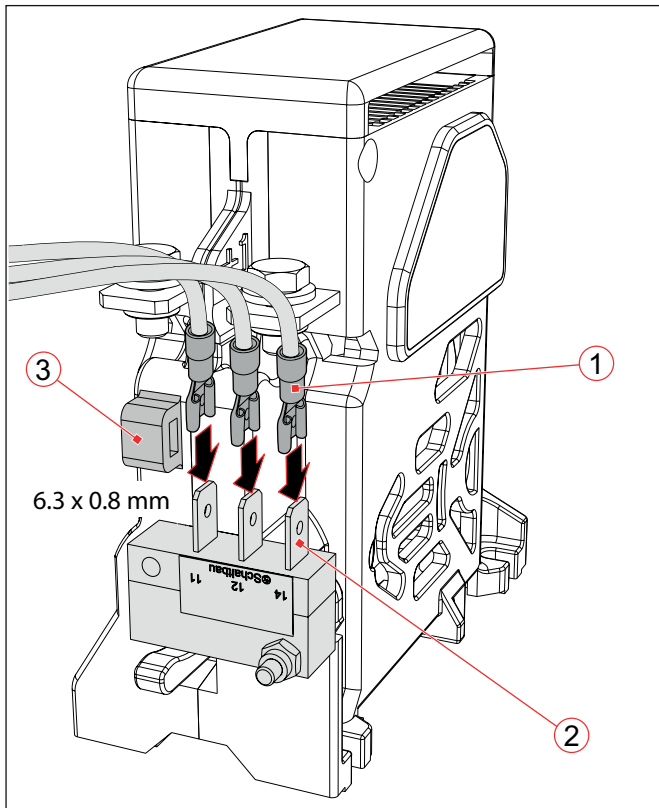

Fig. 9: C193 series: Connect the auxiliary contact (S870)

## Connect the coil terminals

The control wires for the coil connection must be fitted with appropriate flat receptacles (6.3 x 0.8 mm).

### NOTICE

- ▶ Bending of the coil terminals is not permissible!
  - ▶ Move and lay the control wires and flat receptacles only in plugging direction, see *Fig. 11* and *Fig. 12*.
  - ▶ Attach the control wires mechanically, in order to minimize retroactivities (e. g. shock, vibrations) from the wires to the terminals.
- ▶ Plug the prepared control wires with the flat receptacles (4) to both coil terminals A1 and A2 (5).

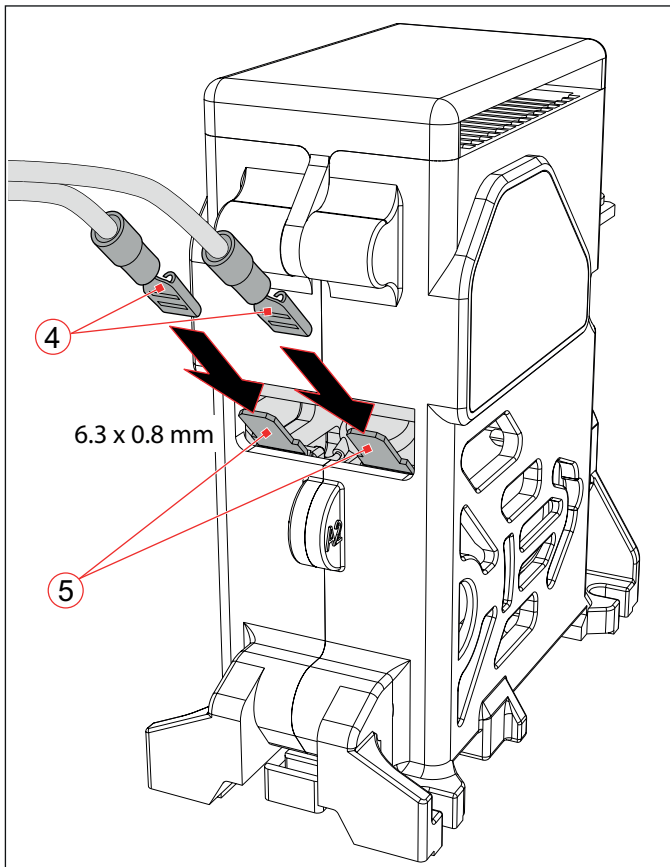

Fig. 11: C193 series: Connect the coil terminals

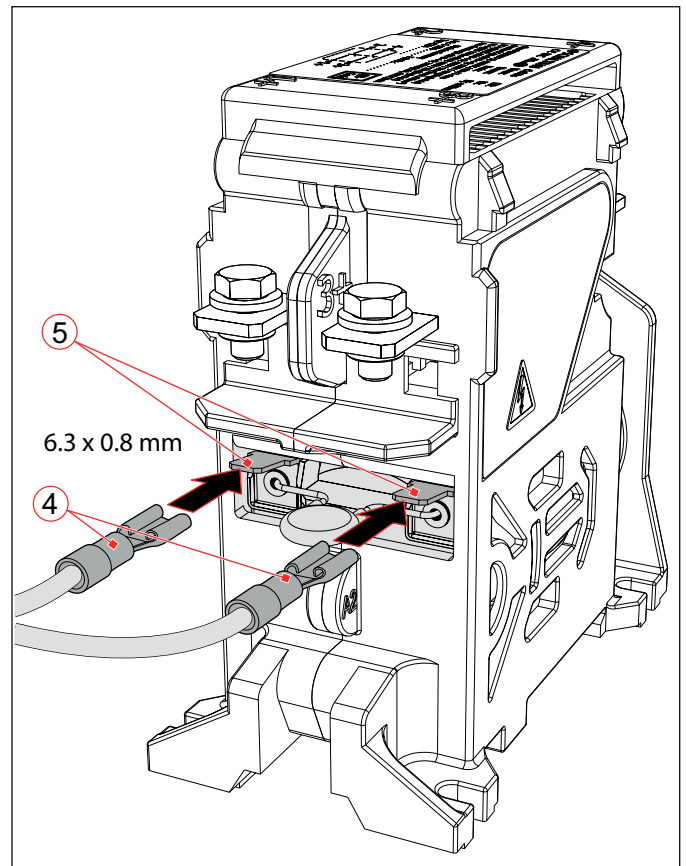

Fig. 12: C294 series: Connect the coil terminals

## Connect the main contacts

### NOTICE

Make sure, that the connection points of the main contacts are free from corrosion.

#### Main contact connection with wires

The wires of the main current circuit must be fitted with appropriate ring cable lugs (for terminal screws M5). Examples for the connection with busbars are shown in Fig. 13 and Fig. 14.

- ▶ Lay the prepared wires (3) to both main contacts (1).
- ▶ Put the ring cable lugs (2) on the main contacts (1).
- ▶ Screw the ring cable lugs (2) with the terminal screws (4) and washers (5) on the main contacts (1).
  - Schaltbau recommends Schnorr-Washers (or similar) to secure the terminal screws.
- ▶ Tighten the terminal screws (4) with the required torque of 3 Nm max.

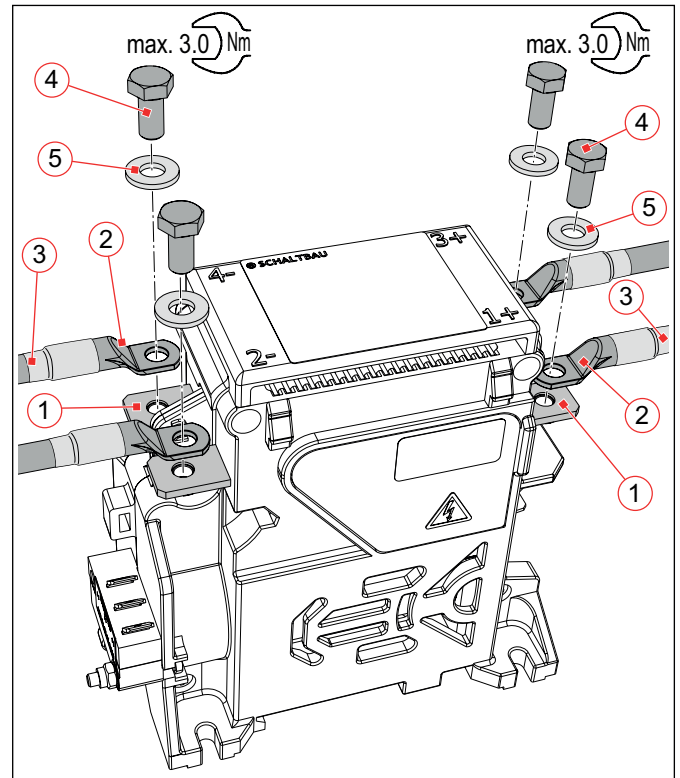

Fig. 14: C294 series: Connect the main contacts (Example for the connection with wires)

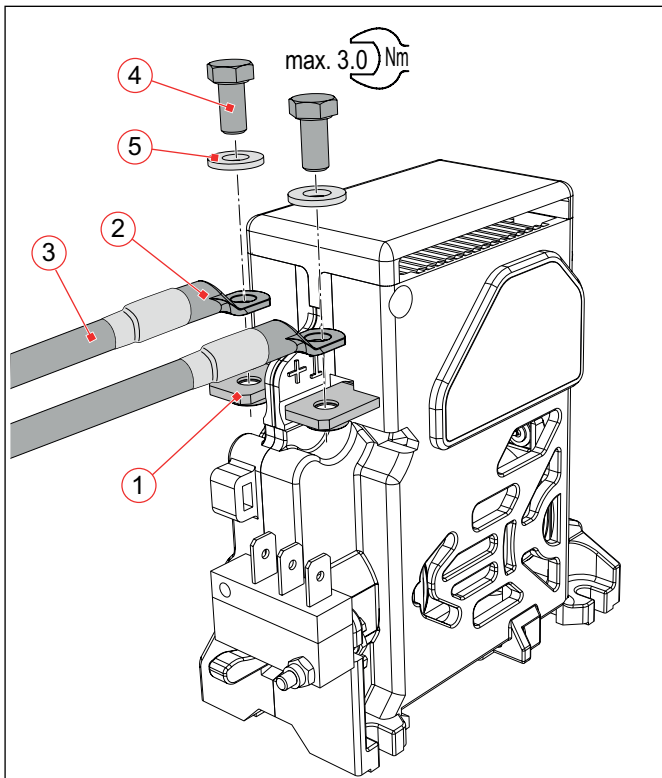

Fig. 13: C193 series: Connect the main contacts (Example for the connection with wires)

**Main contact connection with busbars**

As an alternative to the connection with wires, the main current circuit can also be connected with busbars. Examples for the connection with busbars are shown in **Fig. 15** to **Fig. 17**.

- ▶ Lay the busbars (7) to the main contacts (1).
- ▶ Depending on the installation situation, use additional connecting bars (6) or angled connecting bars (8) if necessary.
- ▶ Connect the busbars (7) to the connecting bars (6) or angled connecting bars (8) using appropriate screws and washers.
  - Schaltbau recommends Schnorr-Washers (or similar) to secure the screws.
- ▶ Connect the connecting bars (6) or angled connecting bars (8) to the main terminals (1) using the terminal screws (4) and washers (5).
- Schaltbau recommends Schnorr-Washers (or similar) to secure the screws.
- ▶ Tighten the terminal screws (4) with the required torque of 3 Nm max.

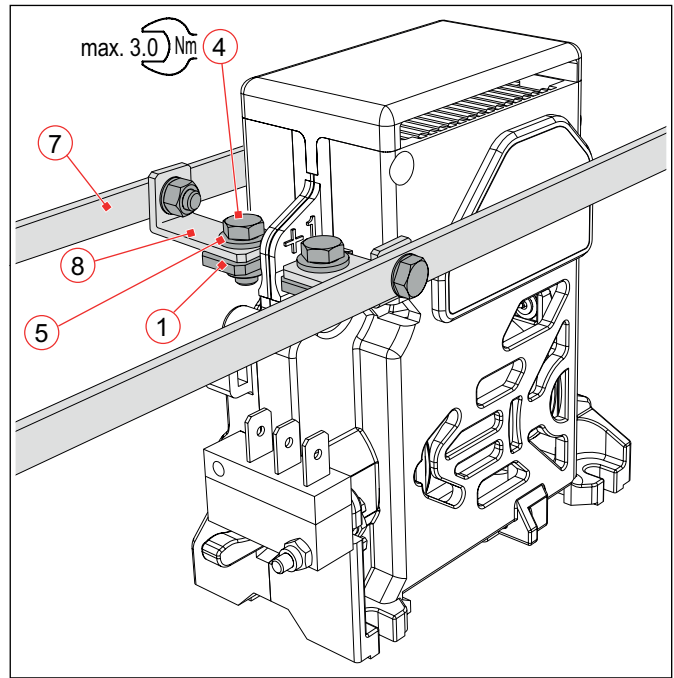

Fig. 16: C193 series: Connect the main contacts (Example for the connection with busbars (7) and angled connecting bars (8))

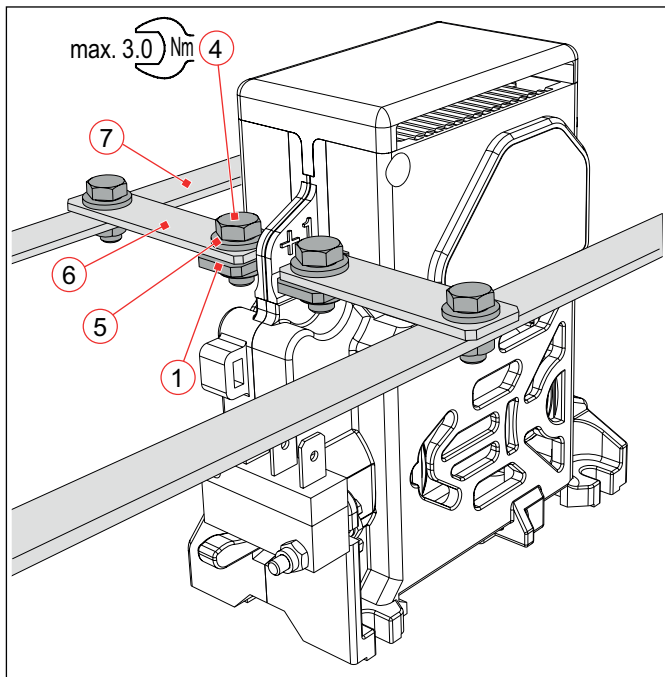

Fig. 15: C193 series: Connect the main contacts (Example for the connection with busbars (7) and connecting bars(6))

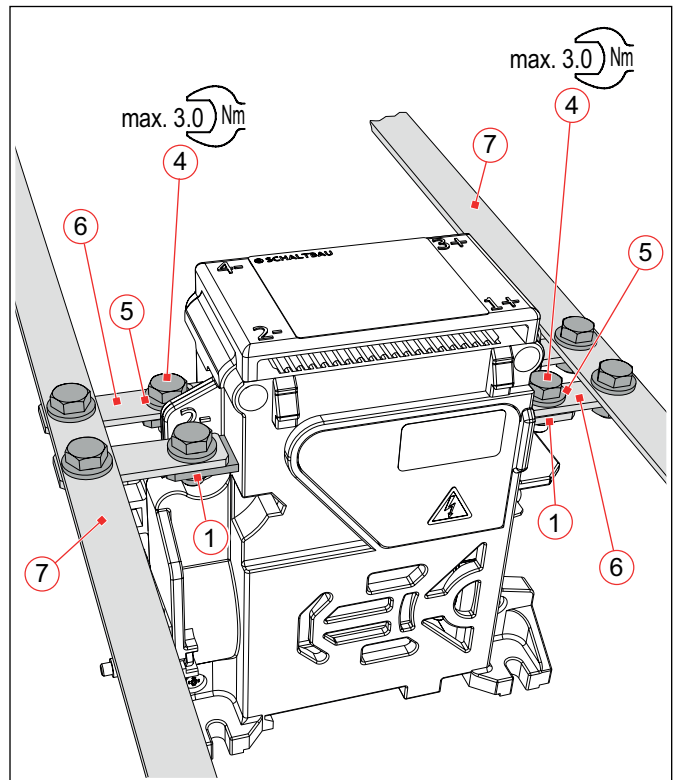

Fig. 17: C294 series: Connect the main contacts (Example for the connection with busbars (7) and connecting bars(6))

## 7.3 Checks

After the installation is completed, do the following checks:

- ▶ Check that the contactors are correctly installed on the base plate and fit tightly.
- ▶ Check that the wires or busbars are correctly installed and fit tightly at the main contacts.
- ▶ Check that the control wires of the coil terminals are correctly installed and in correct polarity.
- ▶ Check that the control wires are properly connected to the auxiliary switch.  
Use a continuity tester to check that the wiring is correct and the auxiliary switch is functioning correctly.
- ▶ Perform several activation and deactivation operations of the contactor without the main circuit active.
- ▶ Check the pull-in and drop-off voltage according to the requirements of Schaltbau. Refer to *catalogues B193* and *B294*.
- ▶ Check the laying of cables. Cables must not be squeezed or bent. If applicable bundle and secure with cable ties.
- ▶ After each installation and after maintenance works, always perform complete checks according to these standards:
  - EN/IEC 60077-2
  - EN/IEC 60947-4-1

## 8. Maintenance

Note the expert knowledge which is essential for carrying out maintenance work, mentioned in chapter "2. General and security information".

### 8.1 Safety

	<b>⚠ DANGER</b>
	<p>The contactors are used to switch voltage. The touching of electrically conducting parts may result in serious injuries or even death!</p> <p>Energized parts are all metal parts belonging directly to one of the circuits or wires leading there. All other visible metal parts and wires may also be energized in the case of a failure.</p> <p>Before beginning any work on the contactors, always observe the following safety regulations:</p> <ul style="list-style-type: none"> <li>▶ Disconnect on all sides</li> <li>▶ Ensure that it is not possible to reconnect unintentionally</li> <li>▶ Clearly mark your work area</li> <li>▶ Make sure that there is no voltage present</li> <li>▶ Earth and short circuit the installation; this also includes the discharging of any capacitors in the main circuit</li> <li>▶ Besides the main electric circuit, also disconnect additional and auxiliary circuits</li> <li>▶ Cover or insulate adjacent energized parts</li> <li>▶ Only an electrically skilled person may determine if there is no voltage present</li> <li>▶ When the work has been concluded, proceed the other way round.</li> </ul>

### 8.2 Preventive maintenance

Contactors of the C193 and C294 series are maintenance-free within the rated mechanical life time. The electrical life time depends on the number of switchings under heavy load conditions and may vary for different applications. In normal use, this corresponds to a decade-long operating period.

#### Intervals for regular checks

To ensure the correct function and a prolonged operational life span of the contactors, the following checks and maintenance must be performed regularly.

Checks	Interval
Visual inspection of the contactor from outside	▶ 1x per year
Inspection of the auxiliary switch	▶ Every 2 years

If the contactors are operated in particularly dirty environments, the checking intervals for visible inspections should be shortened, because dirt can impair the insulation clearances and there is therefore the possibility of a shorter service life or an operational fault.

Extraordinary services need only be carried out if there has been a significant and extraordinary recorded number of switchings under fault conditions.

	<b>⚠ DANGER</b>
	<p>When damages on the contactor, cables or busbars are visible, the safety of the contactor is no longer guaranteed.</p> <ul style="list-style-type: none"> <li>▶ Immediately give damaged contactors or components to corrective maintenance.</li> </ul>

<b>NOTICE</b>
<p>Detent-edged rings and detent-edged washers have a limited life time. After 3 times opening of screws secured with detent-edged rings or detent-edged washers, the rings or washers must be replaced by new ones.</p> <ul style="list-style-type: none"> <li>▶ Record the frequency of screw opening in the work log.</li> <li>▶ After 3 times opening of screws, replace detent-edged rings or detent-edged washers by new ones.</li> </ul>

## Regular check activities

All of the maintenance activities that may be carried out on the contactors by skilled personnel are listed below.

Component	Visual inspection	Measures
Cables/busbars	Check for: <ul style="list-style-type: none"> <li>▶ broken cables, cable lugs</li> <li>▶ damaged insulation</li> <li>▶ kinks or crushing points</li> <li>▶ damaged busbars</li> <li>▶ loose or missing fastening elements</li> <li>▶ correct tightening torque of the terminal screws</li> </ul>	In case of faults: <ul style="list-style-type: none"> <li>▶ immediately replace damaged cables or cable lugs</li> <li>▶ immediately replace damaged busbars</li> <li>▶ tighten loose fastening elements immediately replace missing fastening elements</li> <li>▶ tighten the terminal screws with the rated torque</li> </ul>
Contacteur housing	Check for: <ul style="list-style-type: none"> <li>▶ dirt</li> <li>▶ damage or wear and tear</li> <li>▶ penetrations, holes in the contacteur housing wall</li> <li>▶ loose or missing fastening elements</li> </ul>	In case of faults: <ul style="list-style-type: none"> <li>▶ remove existent dirt</li> <li>▶ if the contacteur housing is damaged or heavily worn replace the entire contacteur</li> <li>▶ in case of penetrations, holes in the contacteur housing wall replace the entire contacteur</li> <li>▶ tighten loose fastening elements and immediately replace missing fastening elements</li> <li>▶ tighten a loose contacteur housing</li> </ul>
Auxiliary contact	Check for: <ul style="list-style-type: none"> <li>▶ dirt</li> <li>▶ damage or wear and tear</li> <li>▶ signs of short circuits</li> </ul> <p>The auxiliary contact is visible for a simple optical inspection from the outside.</p> <p>Under normal working conditions (if there were no short circuits in the control circuit) the life time of the auxiliary contact exceeds those of the contactors.</p>	In case of faults: <ul style="list-style-type: none"> <li>▶ replace auxiliary contact, refer to section "8.3 Corrective maintenance"/ "Replace the auxiliary contact".</li> </ul>

### 8.3 Corrective maintenance

The contactors are maintenance-free. Therefore there is no general provision for replacing components during its service life.

#### Replace the auxiliary contact

Under normal working conditions (if there were no short circuits in the control circuit) the life time of the auxiliary contact exceeds those of the contactors. However, in case of a short circuit in the control circuit it can happen that an auxiliary contact has been damaged and must be replaced.

#### Required tools

- Socket wrench set, hexagon nuts
- Torque wrench
- Continuity tester
- Cable ties

#### Procedure

	<p><b>⚠ DANGER</b></p>
	<p>Before removing the auxiliary contact make sure that</p> <ul style="list-style-type: none"> <li>▶ there is no voltage present,</li> <li>▶ all safety regulations are fully observed.</li> <li>▶ Striktly observe section "8.1 Safety" on page 22.</li> </ul>

- ▶ Disconnect the wires from the auxiliary contact, if necessary.
- ▶ Loosen the self-locking nut (1) and remove it together with the washer.
- ▶ Remove the auxiliary contact (2) and the screw (3) from the housing.
- ▶ Insert the new screw (3) in the housing.
- ▶ Push the new auxiliary contact (2) on the screw (3) in a way so that the locking pin (4) on the housing slides into the second bore hole of the auxiliary contact.
- ▶ Screw on the auxiliary contact using the new self-locking nut (1) and washer.
- ▶ Adjust the auxiliary contact (2) slightly if necessary.
  - The auxiliary contact must switch safely!
- ▶ Thighten the self-locking nut (1) with a torque of 0.5 Nm max.
- ▶ Connect the wires to the new auxiliary contact, see section "7.2 Electrical installation"/"Connect the auxiliary contact".

- ▶ Check that the control wires are properly connected to the auxiliary switch.
- ▶ Use a continuity tester to check that the wiring is correct and the auxiliary switch is functioning correctly.
- ▶ Bundle the control wires with cable ties and fix them to the grommet (5) provided for this purpose.

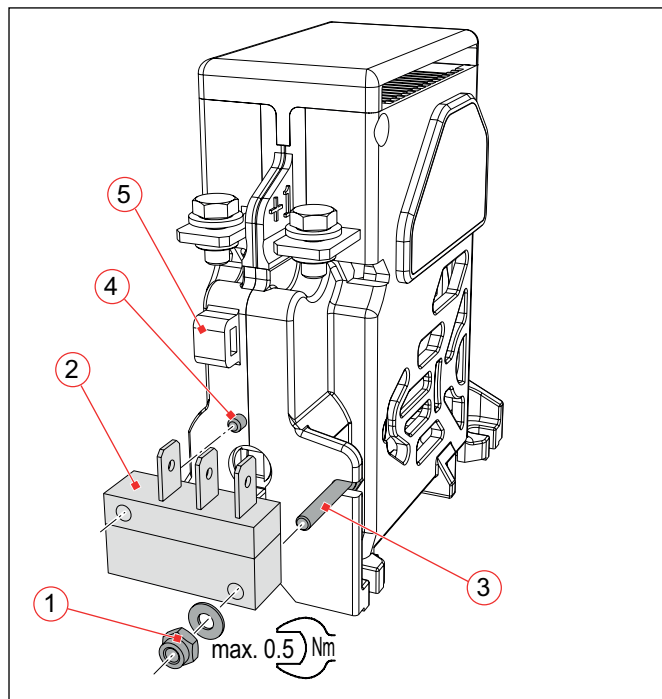

Fig. 18: C193 series: Replace the auxiliary contact

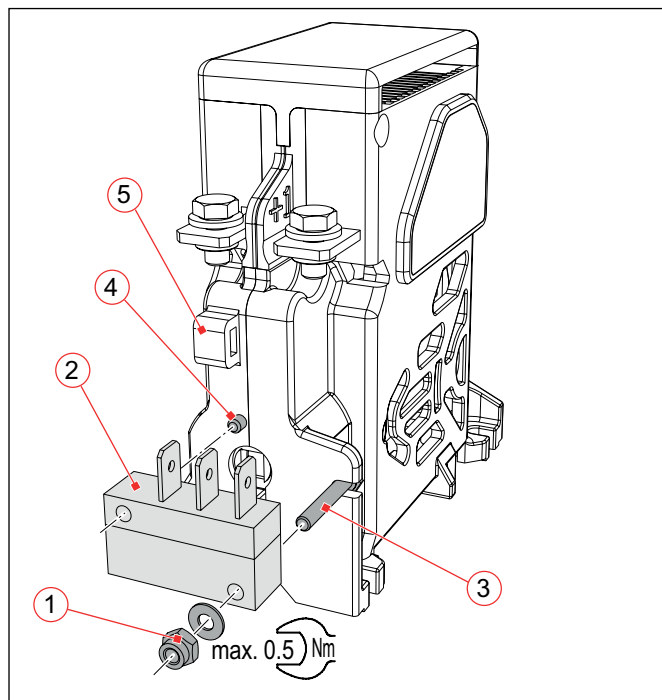

Fig. 19: C294 series: Replace the auxiliary contact



## 9. Spare parts



### Important!

Due to the different versions of auxiliary contacts please quote always the article number of the complete device. You can find this data on the rating plate.

Designation	Article-No.	Type of contactor
Auxiliary contact assembly	1-1693-xxxxxx	C193
	1-1694-xxxxxx	C294

## 10. Technical data

Specifications and information on the material characteristics for the contactors of the C193 and C294 series are given in our catalogues **B193 and B294**.

Due to our continuous improvement programme, the design of our products can be modified at any time. So some features may differ from the descriptions, specifications and drawings in the catalogues. You can download the latest update of the catalogue at: <https://www.schaltbau.com/en/media-library/>

The updated catalogues render the previous issues invalid.

## 11. Disposal

This product is designed for exclusive professional use by commercial companies. The owner is responsible for ensuring an environmentally sound disposal of this product at the end of its working life.

This product or parts of it may not be disposed with other household wastes.

To prevent possible harm to the environment or human health from uncontrolled waste disposal, please separate this product or parts of it from other types of wastes and recycle it responsibly to promote the sustainable reuse of material resources.

Please observe all local regulations and recommendations for the disposal, recycling or environmentally friendly processing of the parts and materials that have been used or replaced during installation, operation, and maintenance tasks. In the end-of life ensure an environmentally sound disposal of the product according to the legal regulations and requirements for electric and electronic waste equipment in your country.

# Notes

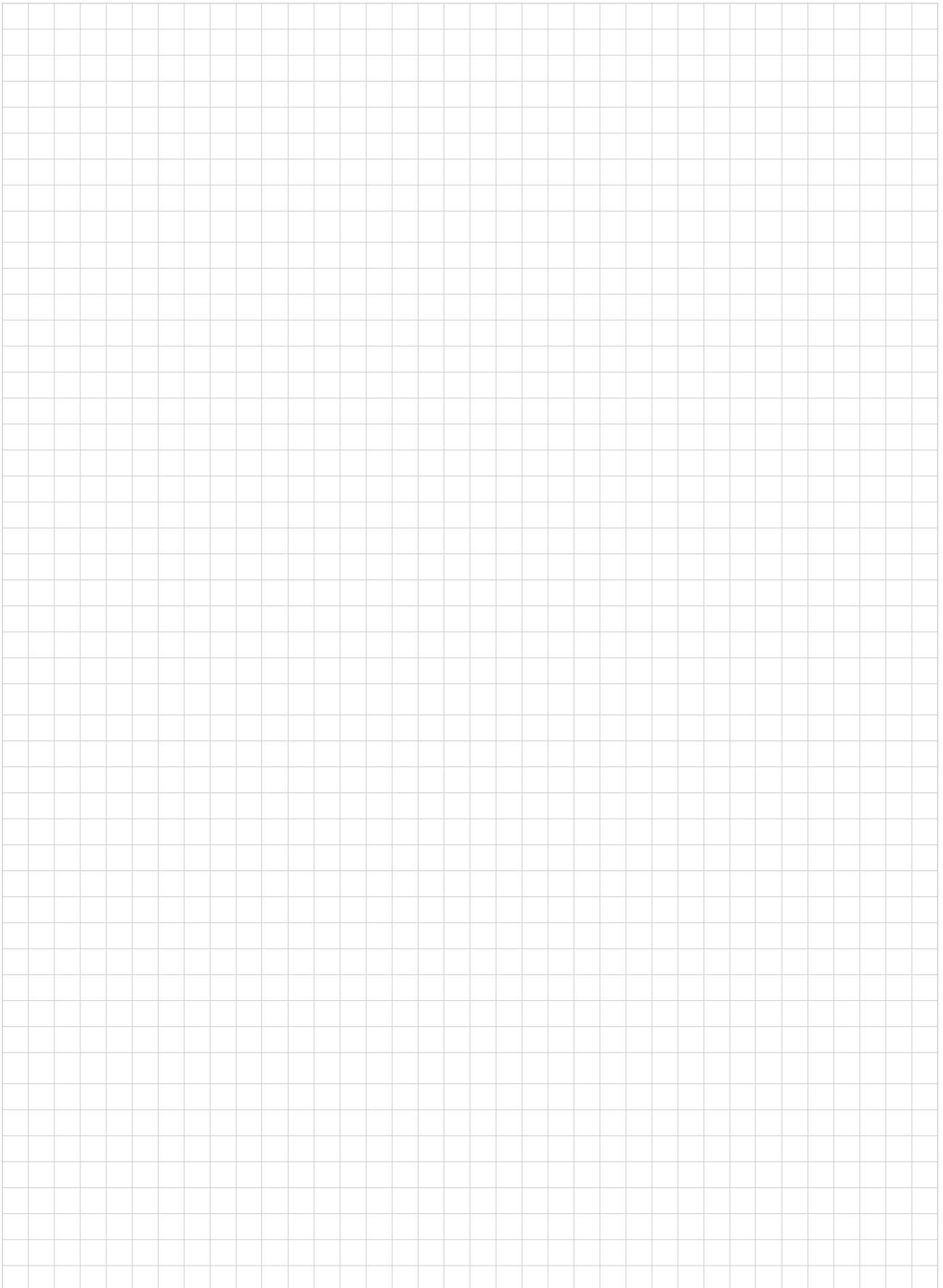

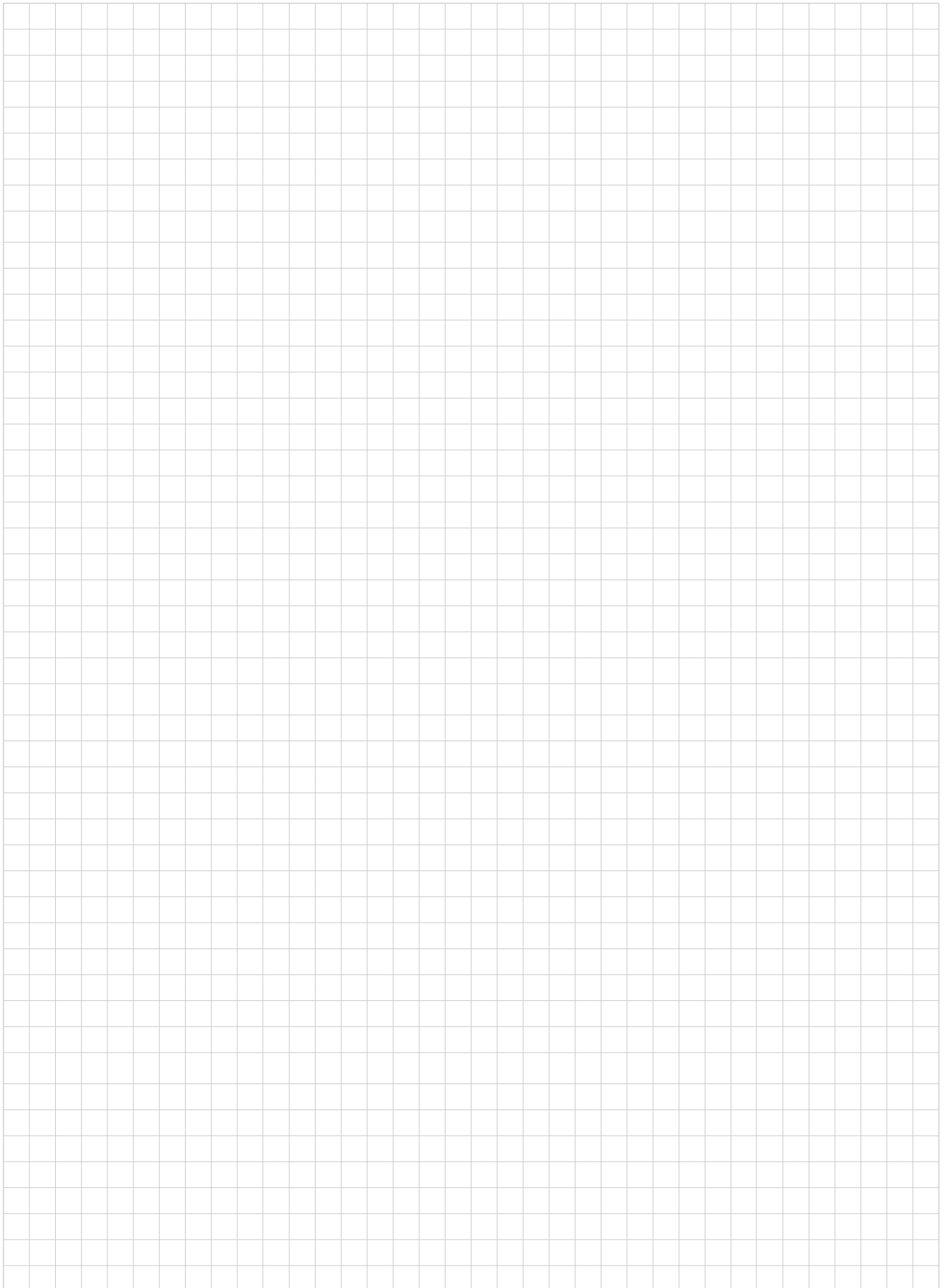

# Schaltbau GmbH

For detailed information on our products and services visit our website – or give us a call!

Schaltbau GmbH  
Hollerithstrasse 5  
81829 Munich  
Germany



Phone +49 89 9 30 05-0  
Fax +49 89 9 30 05-350  
Internet [www.schaltbau.com](http://www.schaltbau.com)  
e-Mail [contact@schaltbau.de](mailto:contact@schaltbau.de)

with compliments:



The production facilities of Schaltbau GmbH have been IRIS certified since 2008.



Certified to DIN EN ISO 14001 since 2002. For the most recent certificate visit our website.



Certified to DIN EN ISO 9001 since 1994. For the most recent certificate visit our website.

## Electrical Components and Systems for Railway Engineering and Industrial Applications

### Connectors

- Connectors manufactured to industry standards
- Connectors to suit the special requirements of communications engineering (MIL connectors)
- Charging connectors for battery-powered machines and systems
- Connectors for railway engineering, including UIC connectors
- Special connectors to suit customer requirements

### Snap-action switches

- Snap-action switches with positive opening operation
- Snap-action switches with self-cleaning contacts
- Snap-action switch made of robust polyetherimide (PEI)
- Snap-action switch with two galvanically isolated contact bridges
- Special switches to suit customer requirements

### Contactors Emergency disconnect switches

- Single and multi-pole DC contactors
- High-voltage AC/DC contactors
- Contactors for battery powered vehicles and power supplies
- Contactors for railway applications
- Terminal bolts and fuse holders
- DC emergency disconnect switches
- Special contactors to suit customer requirements

### Electrics for rolling stock

- Equipment for driver's cab
- Equipment for passenger use
- High-voltage switchgear
- High-voltage heaters
- High-voltage roof equipment
- Equipment for electric brakes
- Design and engineering of train electrics to customer requirements