

# 3

## Contactors

CT1215/04, CT1230/04  
CT1215/08, CT1230/08  
CT1215/11, CT1230/11

2 pole  
AC and bi-directional DC  
NO contactors for  
400 A, 800 A and 1,100 A

Catalogue C21.en

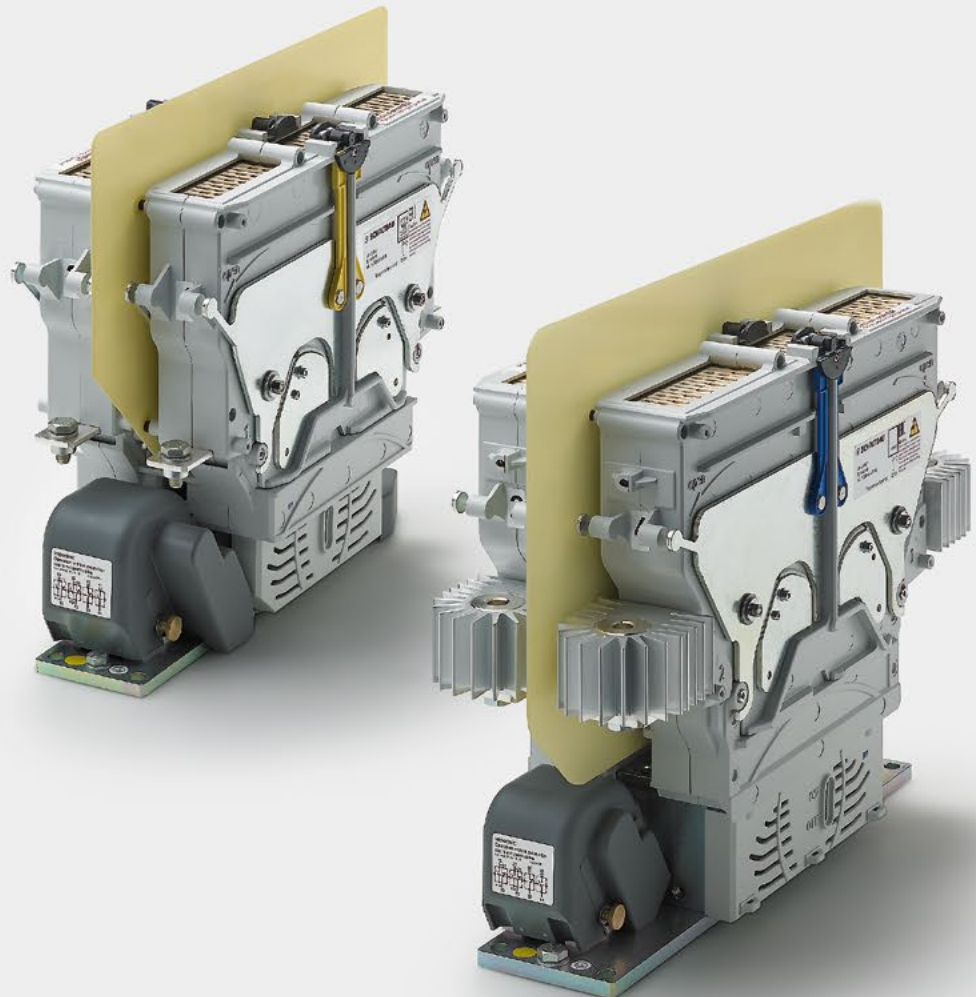

**CT1215/04, CT1230/04** Double pole power contactors for AC and DC, 400 A, 1,500 V oder 3,000 V  
**CT1215/08, CT1230/08** Double pole power contactors for AC and DC, 800 A, 1,500 V oder 3,000 V  
**CT1215/11, CT1230/11** Double pole power contactors for AC and DC, 1,100 A, 1,500 V oder 3,000 V

**CT series – revolutionary method of arc quenching for both DC and AC**

With the double pole CT series contactors Schaltbau expands its product line of state-of-the-art power contactors. The outstanding technical feature is the innovative combination of electromagnetic and permanent-magnetic blowout technology for electric arc control. The successful combination of these two principles greatly improves both switching functionality, reliability and forms a practical and economically impressive device concept.

The CT contactor concept is flexible and can be adapted to suit the needs of the customer. Due to its technical characteristics, its economical advantages, its compactness and versatility, the CT power contactor series is simply predestined for use in industrial and railway applications alike. The contactors are especially suited for use in locomotives, cranes, and converters of wind turbines and PV installations, but also in mining.

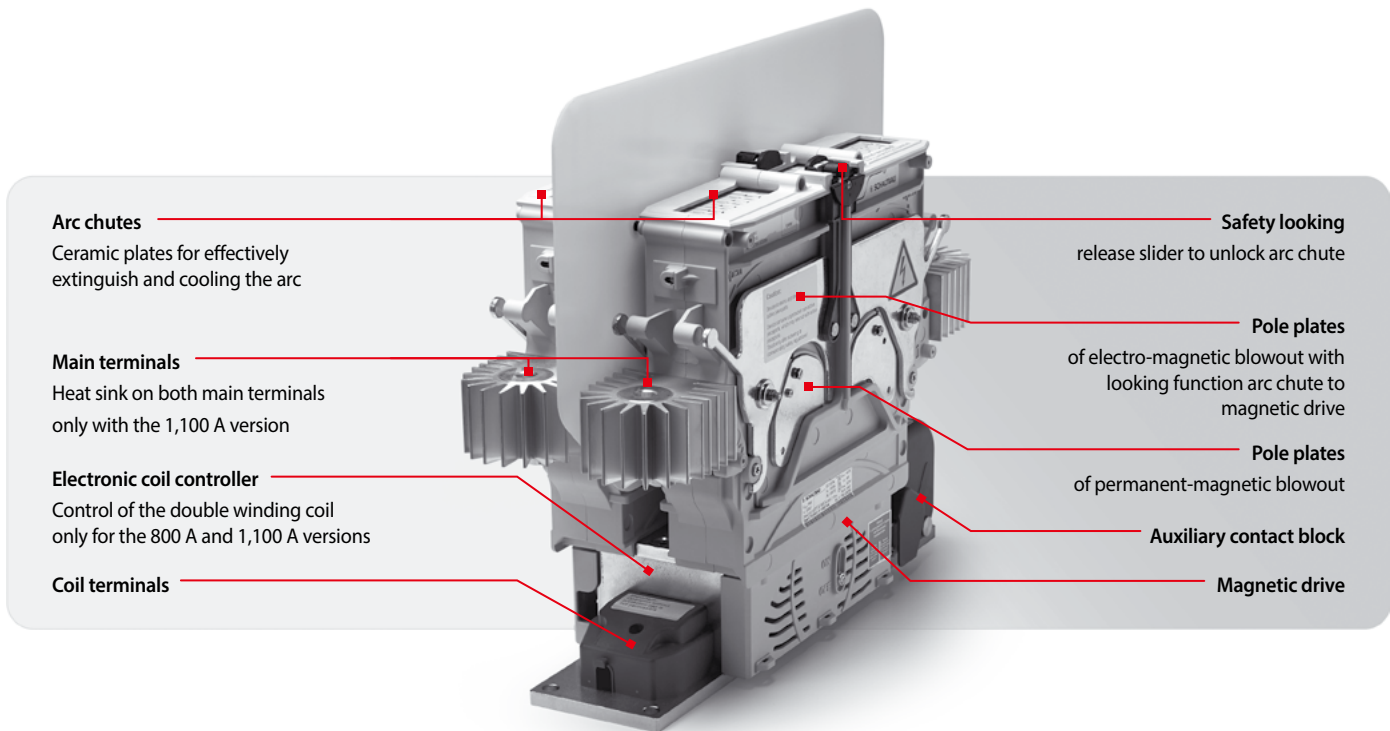

**Arc chutes**  
Ceramic plates for effectively extinguish and cooling the arc

**Main terminals**  
Heat sink on both main terminals only with the 1,100 A version

**Electronic coil controller**  
Control of the double winding coil only for the 800 A and 1,100 A versions

**Coil terminals**

**Safety locking**  
release slider to unlock arc chute



**Pole plates**  
of electro-magnetic blowout with locking function arc chute to magnetic drive

**Pole plates**  
of permanent-magnetic blowout

**Auxiliary contact block**

**Magnetic drive**

**Features**

- **Innovative design:**
  - 1 pole NO contactors, DC bidirectional or AC
  - Contactors for 400 A, 800 A or 1,100 A current rating
  - Nominal voltage 1,500 V or 3,000 V
  - Double-break contacts
  - Reliable shutdown of smaller currents at higher voltages – no critical current range
  - Compact, rugged design
- **Universal use:**
  - Drive system with coil tolerance according to railway standards
  - CCC approval for CT12xx/04, CT12xx/08 and CT12xx/11 
  - UL approval available for selected versions  a list of all UL types can be found here: [schaltbau.info/ct-group-en](https://www.schaltbau.info/ct-group-en)
- **Excellent insulation properties:**
  - Reinforced insulation between main circuit and control circuit/auxiliary circuit
- **Easy maintenance:**
  - Easy inspection and replacement of main contact tips
  - Easy to replace arc chute

**Applications**

- **Main contactor for:**
  - Traction converters
  - Inverters for auxiliary equipment
- **Contactor for:**
  - Field circuits of motors
  - Conventional resistor based traction units (retrofit)
  - Starter and compressor motors
  - Heating circuits
- **Contactor for a host of industrial and railway applications:**
  - Locomotives
  - Cranes
  - Mining

## Competence

### The success of a product is owed to its quality

The Schaltbau product line is clearly defined and keeps up with the technological requirements of today's markets. Behind every individual contactor you will find decades of experience in engineering and manufacturing.

Contactors are remote-controlled electrical switches with which high currents and voltages can be switched. A control current activates the magnetic drive that closes and reopens the contacts of the load current circuit.

The moment of switching off represents a special challenge. The air between the opening contacts becomes ionised and an electric arc

is created in which the current continues to flow. The air between the contacts offers a great deal of electrical resistance, which creates temperatures of up to 10,000 °C. To prevent the contacts or even the entire device from being thermal destroyed, the electric arc must be driven out of the contact area into arc chambers to be stretched and cooled until it loses energy and finally dies out. In order to extinguish the electric arc within a few milliseconds we have incorporated some sophisticated solutions in our contactors.

This experience helps us to develop reliable contactors for power plants, computer centres and electrically powered vehicles.

## Ordering code

Example: **CT1230/04 H 110ET-00**

### Series, contact configuration

CT11	1 pole NO contactor *1
CT12	2 pole NO contactor

### Nominal voltage

15	$U_n = 1,500\text{ V}$
30	$U_n = 3,000\text{ V}$

### Conv. thermal current

04	$I_{th} = 400\text{ A}$
08	$I_{th} = 800\text{ A}$
11	$I_{th} = 1,100\text{ A}$

### Mounting position

H	horizontal (lock bar yellow), for coil suppression T only
V	vertical (lock bar red), for coil suppression T only
N	horizontal or vertical (lock bar blue), for coil suppression CM only

### Coil voltage

24 / 36 / 48 / 72 / 110V DC

### Coil tolerance

E -30 % ... +25 %

### Coil suppression

T	Suppressor diode, (CT12xx/04 only)
CM	Double coil controller with integrated suppressor diode for magnetic drives with double winding coil, (CT12xx/08, CT12xx/11 only)

### Auxiliary switches, number and type

M3 screw-type terminals	1x S870*2 (a1)	00
	1x S870*2 (b0)	
	2x S826 a L*3	
M3 screw-type terminals	1x S870*2 (a1)	01
	1x S870*2 (b0)	
Flat tabs 6.3 x 0.8 mm	2x S826*3	02
M3 screw-type terminals	4x S826*3	
Flat tabs 6.3 x 0.8 mm	4x S826*3	03

\*1 See catalogue C21    \*2 See also catalogue D70    \*3 See also catalogue D26



**Do you need support for a special application? Please contact us! We would be glad to assist you in the selection of the contactor that suits your application best.**



*Presented in this catalogue are only stock items which can be supplied in short delivery time. For some variants minimum quantities apply. Please do not hesitate to ask for the conditions.*

**Special variant:** *If you need a special variant of the contactor, please do not hesitate to contact us. Maybe the type of contactor you are looking for is among our many special designs. If not, we can also supply customized designs. In this case, however, minimum order quantities apply.*

## Standards

- IEC 60077-2** Railway applications – Electric equipment for rolling stock – Part 2: Electrotechnical components; General rules
- IEC 62497-1** Railway applications – Insulation coordination – Part 1: Basic requirements – Clearances and creepage distances for all electrical and electronic equipment
- IEC 61373** Railway applications – Rolling stock equipment – Shock and vibration tests

- IEC 60947-4-1** Low-voltage switchgear and controlgear – Part 4-1: Contactors and motor-starters – Electromechanical contactors and motor-starters
- IEC 62236-3-2** Railway applications – Electromagnetic compatibility – Part 3-2: Rolling stock – Apparatus

**Specifications** Double pole power contactors for AC and DC, Nominal voltage = 1,500 V

CT series

Series		CT1215/04	CT1215/08	CT1215/11
Type of voltage Number of poles, configuration		DC (bidirectional), AC (f ≤ 60 Hz) 2x SPST-NO		
<b>Electrical ratings of main circuit to IEC 60077-2</b>				
Nominal voltage	U <sub>n</sub>	1,500 V	1,500 V	1,500 V
Rated operating voltage	U <sub>r</sub>	1,800 V	1,800 V	1,800 V
Rated insulation voltage	U <sub>Nm</sub>	3,000 V	3,000 V	3,000 V
Rated impulse withstand voltage	U <sub>Ni</sub>	15 kV	15 kV	15 kV
Pollution degree / Overvoltage category		PD3 / OV2	PD3 / OV2	PD3 / OV2
Switching overvoltages	@ U <sub>e</sub> = 1,800 V	<9 kV (<11 kV @ T2 = 40 ms)	<9 kV (<11 kV @ T2 = 40 ms)	<9 kV (<11 kV @ T2 = 40 ms)
Conventional thermal current	I <sub>th</sub>	400 A *1	800 A	1,100 A
Component category		A2	A2	A2
Short-circuit making capacity, new/used contacts		2.5 kA / 5 kA	3.5 kA / 8 kA	3.5 kA / 8 kA
Rated operating current I <sub>e</sub> (2 poles in series, @ operational frequency C2) DC, U <sub>e</sub> = 1,800 V (T2 = 15 ms) DC, U <sub>e</sub> = 3,600 V (T2 = 15 ms)		450 A ---	800 A ---	800 A ---
Rated operating current I <sub>e</sub> (per pole, @ operational frequency C2) DC, U <sub>e</sub> = 1,800 V (T2 = 15 ms) DC, U <sub>e</sub> = 3,600 V (T2 = 15 ms)		300 A ---	450 A ---	450 A ---
Rated short-circuit breaking capacity (T2 = 15 ms)	DC, U <sub>e</sub> = 1,200 V DC, U <sub>e</sub> = 1,800 V DC, U <sub>e</sub> = 3,600 V	1,400 A 800 A ---	2,000 A 1,400 A ---	2,000 A 1,400 A ---
Rated short-circuit breaking capacity (T2 = 1 ms)	DC, U <sub>e</sub> = 1,200 V DC, U <sub>e</sub> = 1,800 V DC, U <sub>e</sub> = 3,600 V	2,600 A 1,800 A ---	4,200 A 3,000 A ---	4,200 A 3,000 A ---
Rated short-circuit breaking capacity (cosφ = 0.8) AC, U <sub>e</sub> = 1,200 V (f = 16.7 / 50 Hz) AC, U <sub>e</sub> = 1,800 V (f = 16.7 / 50 Hz) AC, U <sub>e</sub> = 3,600 V (f = 16.7 / 50 Hz)		1,000 A / 700 A 800 A / 500 A --- / ---	1,900 A / 1,400 A 1,500 A / 1,000 A --- / ---	1,900 A / 1,400 A 1,500 A / 1,000 A --- / ---
Rated short-circuit breaking capacity (cosφ = 1) AC, U <sub>e</sub> = 1,200 V (f = 16.7 / 50 Hz) AC, U <sub>e</sub> = 1,800 V (f = 16.7 / 50 Hz) AC, U <sub>e</sub> = 3,600 V (f = 16.7 / 50 Hz)		1,300 A / 1,000 A 1,000 A / 700 A --- / ---	2,200 A / 1,600 A 1,900 A / 1,200 A --- / ---	2,200 A / 1,600 A 1,900 A / 1,200 A --- / ---
Rated short-time withstand current I <sub>cw</sub>	per Pol, T < 100 ms	5 kA (T < 100 ms)	8 kA (T < 100 ms) *2	8 kA (T < 100 ms), 20 kA (T < 20 ms)
Critical current range		None	None	None
Design Contact material Terminals / Torque		AgSnO <sub>2</sub> M10 / 16 ... 20 Nm	AgSnO <sub>2</sub> M12 / 24 ... 30 Nm	AgSnO <sub>2</sub> M12 / 24 ... 30 Nm
<b>Auxiliary contacts</b>				
Number and type Contact material Switching capacity Terminals	S826, T = 5 ms	1x S870 (a <sub>1</sub> )*4, 1x S870 (b <sub>0</sub> )*4, 2x S826 or 4x S826 Silver 16 A @ 24 V DC; 13.5 A @ 80 V DC; 7 A @ 110 V DC Screws M3 / Flat tabs 6.3 x 0.8 mm		
<b>Magnetic drive (monostable)</b>				
Coil voltage Pollution degree / overvoltage category Coil tolerance	U <sub>s</sub>	24 / 36 / 48 / 72 / 110 V DC PD3 / OV2 -30 % ... +25 % U <sub>s</sub>	24 / 36 / 48 / 72 / 110 V DC PD3 / OV2 -30 % ... +25 % U <sub>s</sub>	24 / 36 / 48 / 72 / 110 V DC PD3 / OV2 -30 % ... +25 % U <sub>s</sub>
Coil power dissipation	@ U <sub>s</sub> and T <sub>a</sub> = 20 °C	Cold coil 70 W Warm coil 50 W	Pull-in (1 s max.) 280 W Hold 27 W	Pull-in (1 s max.) 330 W Hold 50 W
Pull-in voltage, typical Pull-in time, typical Drop-off voltage, typical Drop-off time, typical	@ T <sub>a</sub> = 20 °C @ T <sub>a</sub> = 20 °C @ T <sub>a</sub> = 20 °C @ T <sub>a</sub> = 20 °C	0.6 x U <sub>s</sub> 85 ms > 0.08 x U <sub>s</sub> 50 ms	0.6 x U <sub>s</sub> 95 ms > 0.08 x U <sub>s</sub> 95 ms	0.6 x U <sub>s</sub> 130 ms *2 > 0.08 x U <sub>s</sub> 100 ms
Coil design / Coil suppression Suppressor diode Double coil controller with integrated suppressor diode		Standard coil ● ---	Double winding coil ● ---	Double winding coil ● ---
Coil terminal		Cage clamp	Cage clamp	Cage clamp
Degree of protection		IP00		
Mechanical endurance		> 2 million operating cycles	> 2 million operating cycles	> 1 million operating cycles
Vibration / shock	IEC 61373	Category 1, class B		
Mounting position		horizontal / vertical		
Temperatures Operating temperature / Storage temperature Altitude / Humidity (EN 50125-1)		-40 °C ... +70 °C / -40 °C ... +85 °C < 2,000 m above sea level / < 75 % yearly average		
Weight		11 kg	18 kg	20 kg



 \*1 With frequent switching under load the conv. thermal current I<sub>th</sub> must be limited to 350 A.

\*2 Preliminary values

\*3 »Observe dimensioning instructions for CT1230/08 Series on page 10

 \*4 a<sub>1</sub> and b<sub>0</sub> according to IEC60077-2 (Aux. contact b<sub>0</sub> „well open“ or mirror contact for feedback circuits of safety-relevant controls according to DIN EN 13849-1)

\*5 For frequent load switching use contactors for vertical mounting (red lock bars).

**Specifications** Double pole power contactors for AC and DC, Nominal voltage = 3,000 V

CT series

Series		CT1230/04	CT1230/08	CT1230/11
Type of voltage		DC (bidirectional), AC (f ≤ 60 Hz)		
Number of poles, configuration		2x SPST-NO		
<b>Electrical ratings of main circuit to IEC 60077-2</b>				
Nominal voltage	$U_n$	3,000 V	3,000 V	3,000 V
Rated operating voltage	$U_r$	3,600 V	3,600 V	3,600 V
Rated insulation voltage	$U_{Nm}$	4,800 V	4,800 V	4,800 V
Rated impulse withstand voltage	$U_{Ni}$	25 kV	25 kV	25 kV
Pollution degree / Overvoltage category		PD3 / OV2	PD3 / OV2	PD3 / OV2
Switching overvoltages	@ $U_e = 1,800$ V	< 14.4 kV	< 15 kV	< 15 kV
Conventional thermal current	$I_{th}$	400 A *1	800 A	1,100 A
Component category		A2	A2	A2
Short-circuit making capacity, new/used contacts		3.5 kA / 5 kA	4 kA / 8 kA	4 kA / 8 kA
Rated operating current $I_e$ (2 poles in series, @ operational frequency C2) DC, $U_e = 1,800$ V (T2 = 15 ms) DC, $U_e = 3,600$ V (T2 = 15 ms)		350 A (extrapolated value)	800 A	800 A
Rated operating current $I_e$ (per pole, @ operational frequency C2) DC, $U_e = 1,800$ V (T2 = 15 ms) DC, $U_e = 3,600$ V (T2 = 15 ms)		200 A	320 A	320 A
Rated short-circuit breaking capacity (T2 = 15 ms)	DC, $U_e = 1,200$ V DC, $U_e = 1,800$ V DC, $U_e = 3,600$ V	--- 1,200 A 750 A	--- 2,000 A 1,200 A *3	--- 2,000 A 1,200 A
Rated short-circuit breaking capacity (T2 = 1 ms)	DC, $U_e = 1,200$ V DC, $U_e = 1,800$ V DC, $U_e = 3,600$ V	--- 2,900 A 1,400 A	--- 3,400 A 2,300 A *3	--- 3,400 A 2,300 A
Rated short-circuit breaking capacity ( $\cos\phi = 0.8$ ) AC, $U_e = 1,200$ V (f = 16.7 / 50 Hz) AC, $U_e = 1,800$ V (f = 16.7 / 50 Hz) AC, $U_e = 3,600$ V (f = 16.7 / 50 Hz)		--- / --- 1,600 A / 900 A 900 A / 500 A	--- / --- 2,300 A / 1,500 A 1,300 A / 900 A	--- / --- 2,300 A / 1,500 A 1,300 A / 900 A
Rated short-circuit breaking capacity ( $\cos\phi = 1$ ) AC, $U_e = 1,200$ V (f = 16.7 / 50 Hz) AC, $U_e = 1,800$ V (f = 16.7 / 50 Hz) AC, $U_e = 3,600$ V (f = 16.7 / 50 Hz)		--- / --- 2,100 A / 1,200 A 1,300 A / 800 A	--- / --- 2,900 A / 1,700 A 1,600 A / 1,300 A	--- / --- 2,900 A / 1,700 A 1,600 A / 1,300 A
Rated short-time withstand current $I_{cw}$	per Pol, T < 100 ms	6 kA	8 kA *2	8 kA *2
Critical current range		None	None	None
Design				
Contact material		AgSnO <sub>2</sub>	AgSnO <sub>2</sub>	AgSnO <sub>2</sub>
Terminals / Torque		M10 / 16 ... 20 Nm	M12 / 24 ... 30 Nm	M12 / 24 ... 30 Nm
<b>Auxiliary contacts</b>				
Number and type		1x S870 (a <sub>1</sub> )*4, 1x S870 (b <sub>0</sub> )*4, 2x S826 or 4x S826		
Contact material		Silver		
Switching capacity	S826, T = 5 ms	16 A @ 24 V DC; 13.5 A @ 80 V DC; 7 A @ 110 V DC		
Terminals		Screws M3 / Flat tabs 6.3 x 0.8 mm		
<b>Magnetic drive (monostable)</b>				
Coil voltage	$U_s$	24 / 36 / 48 / 72 / 110 V DC	24 / 36 / 48 / 72 / 110 V DC	24 / 36 / 48 / 72 / 110 V DC
Pollution degree / overvoltage category		PD3 / OV2	PD3 / OV2	PD3 / OV2
Coil tolerance		-30 % ... +25 % $U_s$	-30 % ... +25 % $U_s$	-30 % ... +25 % $U_s$
Coil power dissipation	@ $U_s$ and $T_a = 20$ °C	Cold coil 70 W Warm coil 50 W	Pull-in (1 s max.) 280 W Hold 27 W	Pull-in (1 s max.) 330 W Hold 50 W
Pull-in voltage, typical	@ $T_a = 20$ °C	0.6 x $U_s$	0.6 x $U_s$	0.6 x $U_s$
Pull-in time, typical	@ $T_a = 20$ °C	120 ms	95 ms	95 ms
Drop-off voltage, typical	@ $T_a = 20$ °C	> 0.08 x $U_s$	> 0.08 x $U_s$	> 0.08 x $U_s$
Drop-off time, typical	@ $T_a = 20$ °C	60 ms	95 ms	95 ms
Coil design / Coil suppression		Standard coil	Double winding coil	Double winding coil
Suppressor diode		•	•	•
Double coil controller with integrated suppressor diode		---	---	•
Coil terminal		Cage clamp	Cage clamp	Cage clamp
<b>Degree of protection</b>				
IP00				
<b>Mechanical endurance</b>				
		> 2 million operating cycles	> 2 million operating cycles	> 1 million operating cycles
<b>Vibration / shock</b>				
IEC 61373		Category 1, class B		
<b>Mounting position</b>				
horizontal / vertical				
<b>Temperatures</b>				
Operating temperature / Storage temperature		-40 °C ... +70 °C / -40 °C ... +85 °C		
Altitude / Humidity (EN 50125-1)		< 2,000 m above sea level / < 75 % yearly average		
<b>Weight</b>		13 kg	21 kg	23 kg

**SCHALTBAU**
\*1 With frequent switching under load the conv. thermal current  $I_{th}$  must be limited to 350 A.

\*2 Preliminary values

\*3 »Observe dimensioning instructions for CT1230/08 Series on page 10

\*4  $a_1$  and  $b_0$  according to IEC60077-2 (Aux. contact  $b_0$  „well open“ or mirror contact for feedback circuits of safety-relevant controls according to DIN EN 13849-1)

\*5 For frequent load switching use contactors for vertical mounting (red lock bars).

Subject to change

**CT1215/04** Dimension diagram double pole NO contactor for 1,500 V / 400 A

CT series

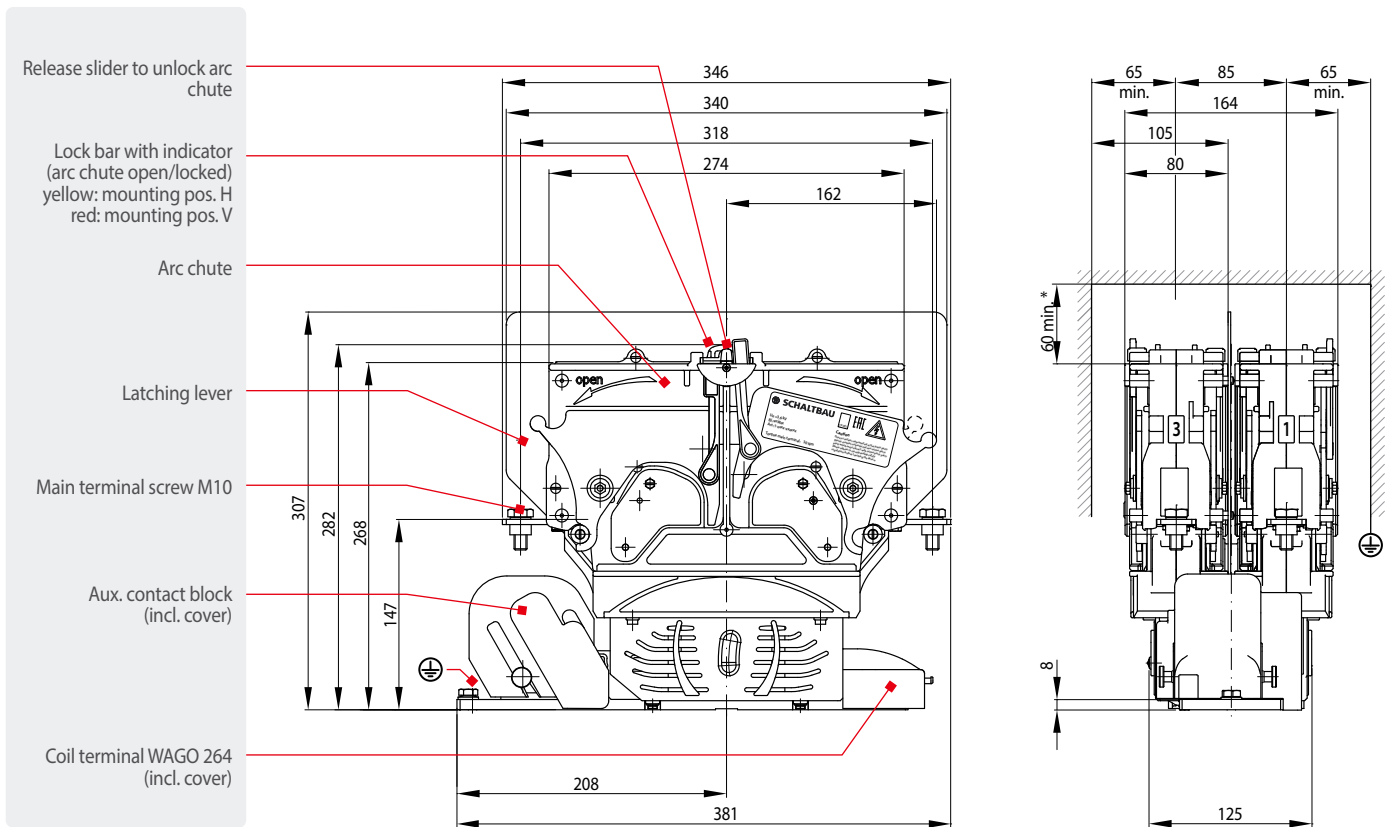

**CT1215/08** Dimension diagram double pole NO contactor for 1,500 V / 800 A

CT series

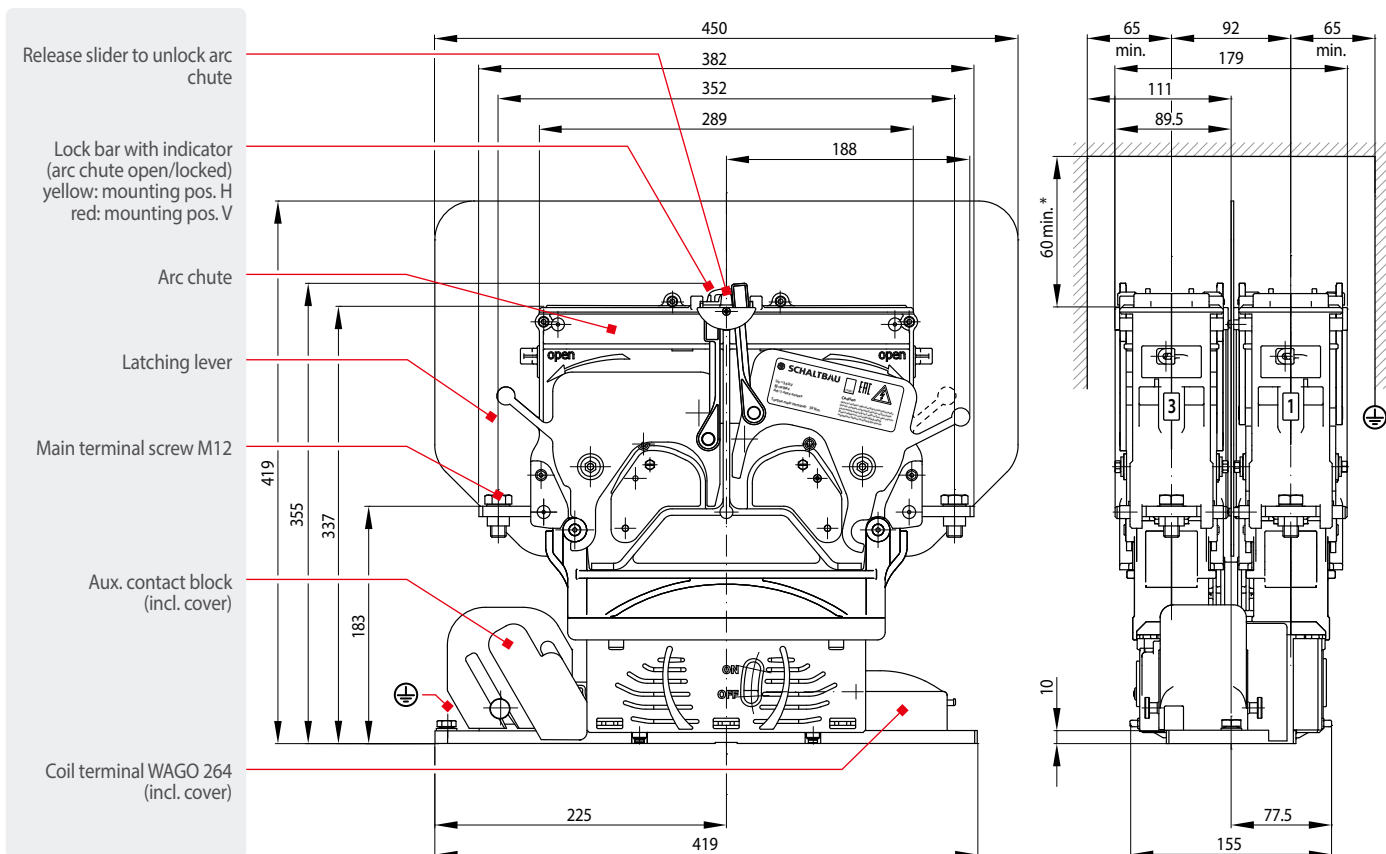

\* Interrupting at maximum capacity could require larger clearance!  
Feel free to contact us, we will be happy to assist you with dimensioning.

**CT1230/04** Dimension diagram double pole NO contactor for 3,000 V / 400 A

CT series

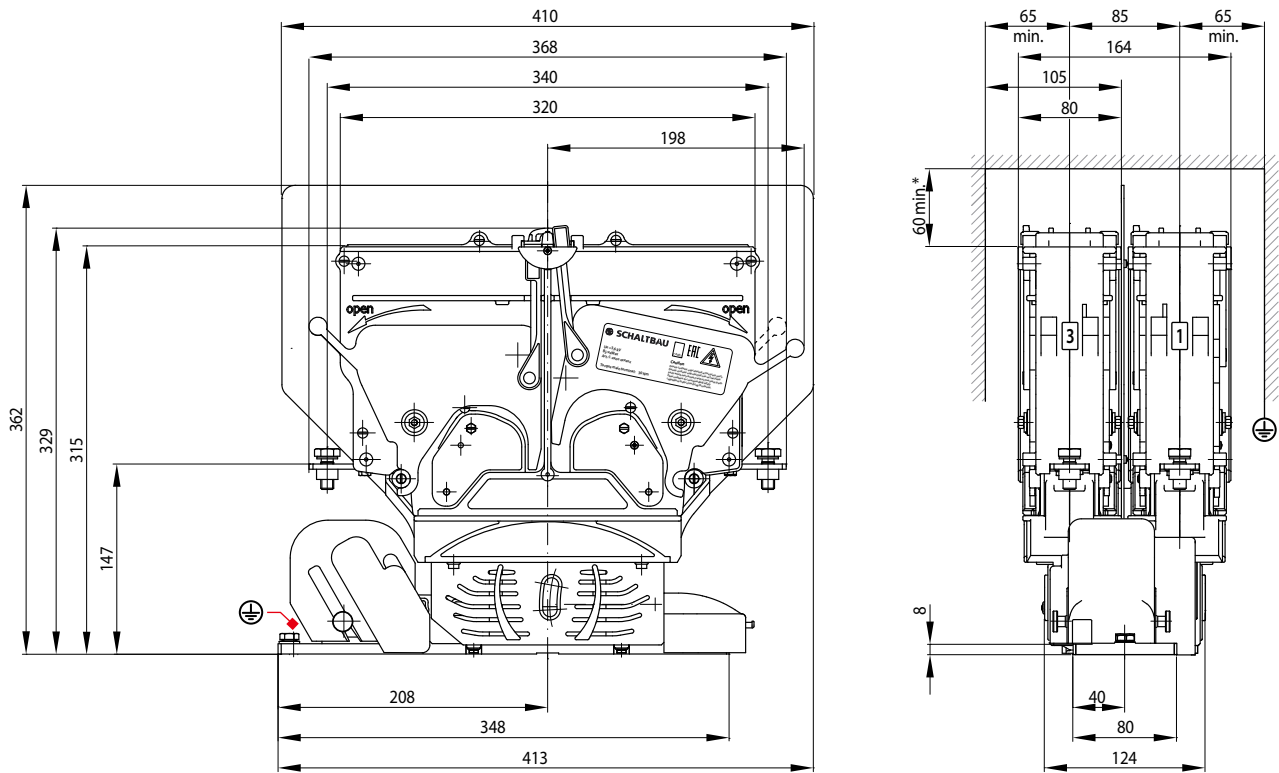

**CT1230/08** Dimension diagram double pole NO contactor for 3,000 V / 800 A

CT series

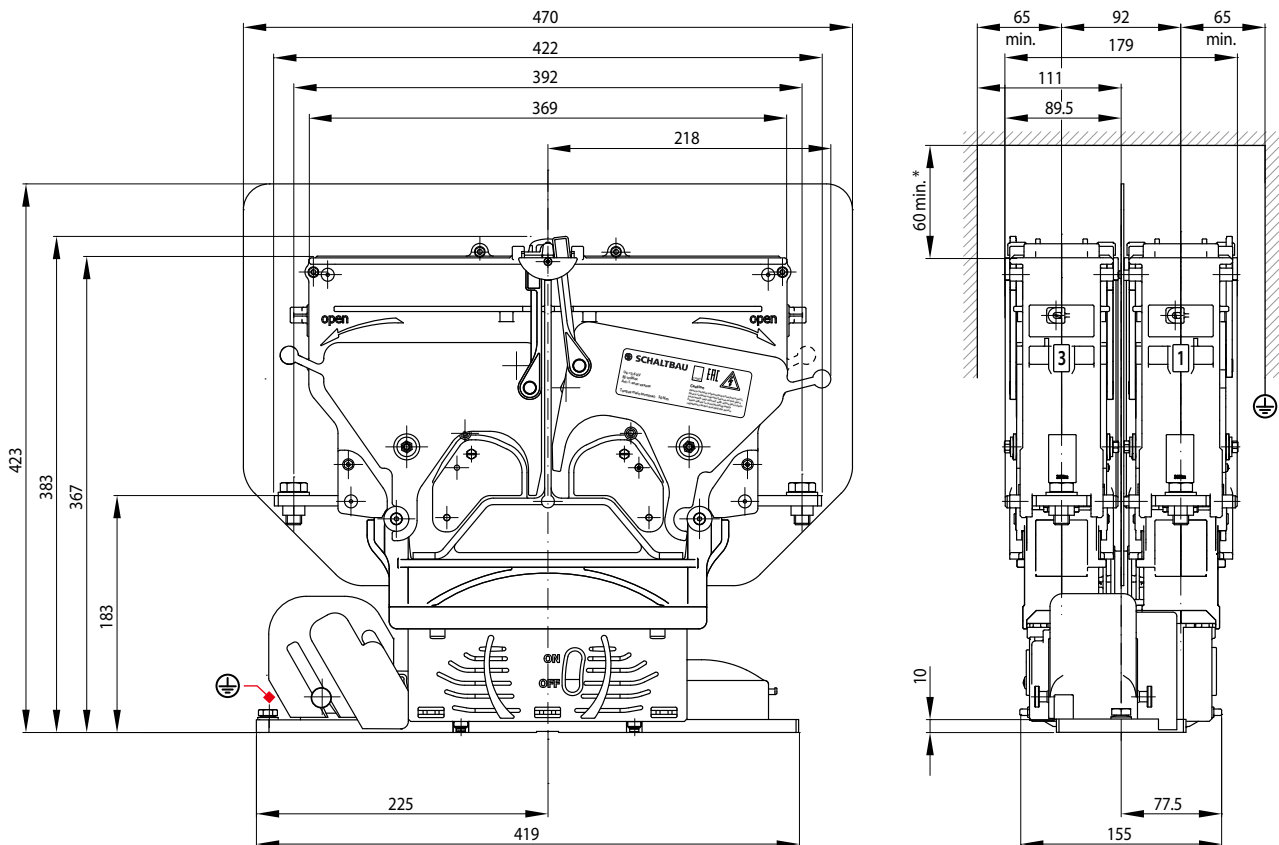

\* Interrupting at maximum capacity could require larger clearance!  
 Feel free to contact us, we will be happy to assist you with dimensioning.

**CT1215/11** Dimension diagram double pole NO contactor for 1,500 V / 1,100 A

CT series

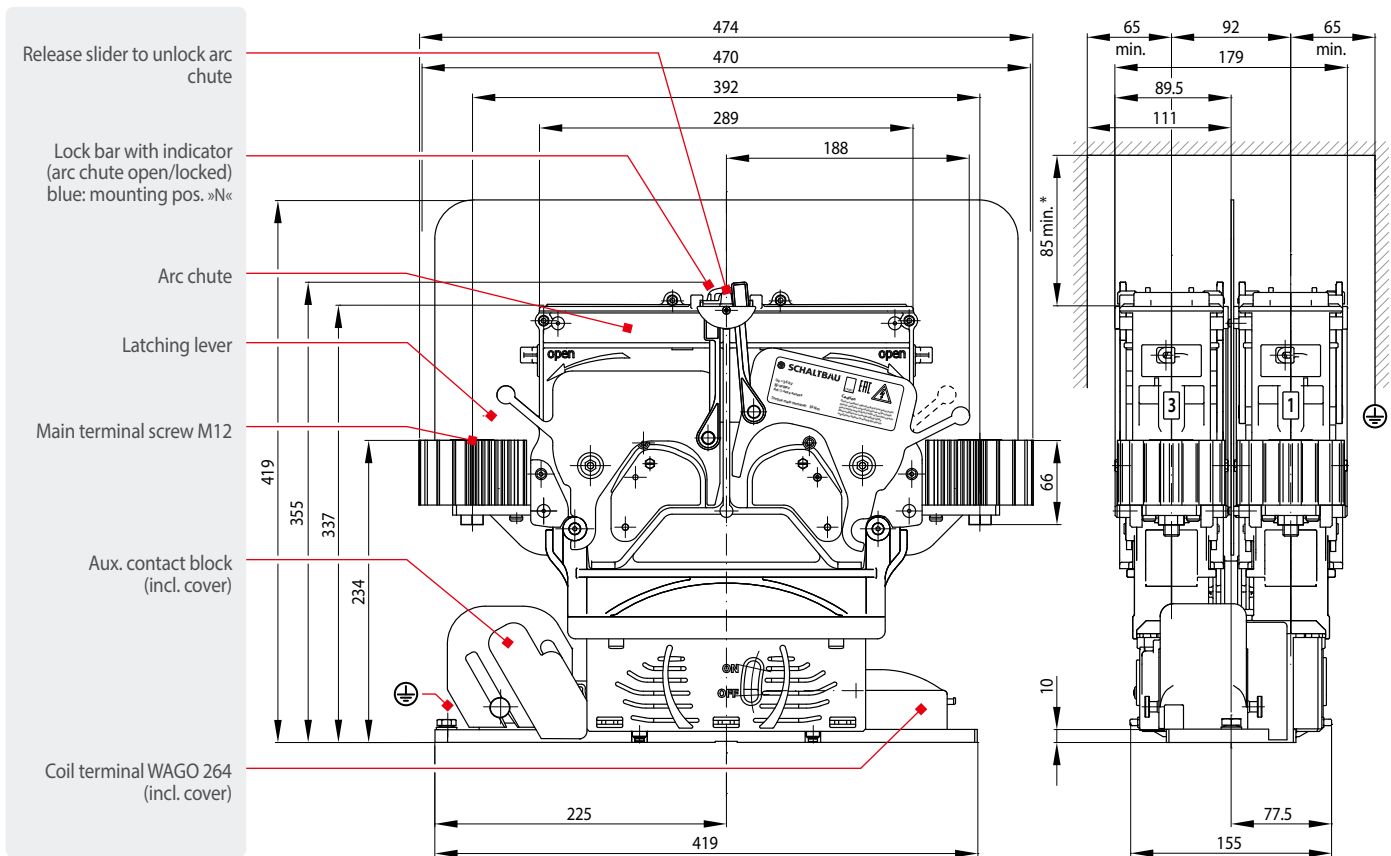

\* Interrupting at maximum capacity could require larger clearance!  
 Feel free to contact us, we will be happy to assist you with dimensioning.

**Circuit diagrams**

CT series

- Versions according to railway standard for railway applications or with mirror contact for industrial applications

**CT1215/04, CT1230/04**

Main contacts 2x NO,  $I_{th} = 400$  A  
 Aux. contacts (EN 60077) 2 x S826, 1 x S870(b0), 1 x S870(a1)  
 Magnetic drive Coil suppression «T»  
 Standard coil with suppressor diode

Circuit diagram

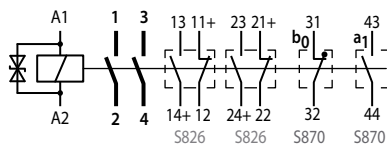

**CT1215/08, CT1230/08, CT1215/11, CT1230/11**

Main contacts 2x NO,  $I_{th} = 800$  A / 1,100 A  
 Aux. contacts (EN 60077) 2 x S826, 1 x S870(b0), 1 x S870(a1)  
 Magnetic drive Coil suppression «CM»  
 Double coil controller (DCC) with integrated suppressor diode for magnetic drives with double winding coil

Circuit diagram

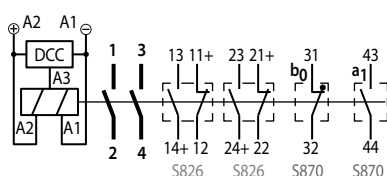

- Versions for industrial applications without mirror contact

**CT1215/04, CT1230/04**

Main contacts 2x NO,  $I_{th} = 400$  A  
 Auxiliary contacts 4 x S826  
 Magnetic drive Coil suppression «T»  
 Standard coil with suppressor diode

Circuit diagram

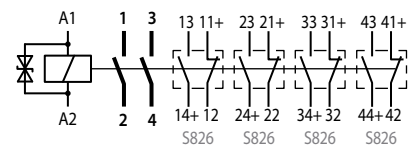

**CT1215/08, CT1230/08, CT1215/11, CT1230/11**

Main contacts 2x NO,  $I_{th} = 800$  A / 1,100 A  
 Auxiliary contacts 4 x S826  
 Magnetic drive Coil suppression «CM»  
 Double coil controller (DCC) with integrated suppressor diode for magnetic drives with double winding coil

Circuit diagram

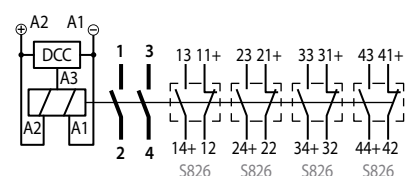



**CT1230/11** Dimension diagram double pole NO contactor for 3,000 V / 1,100 A

CT series

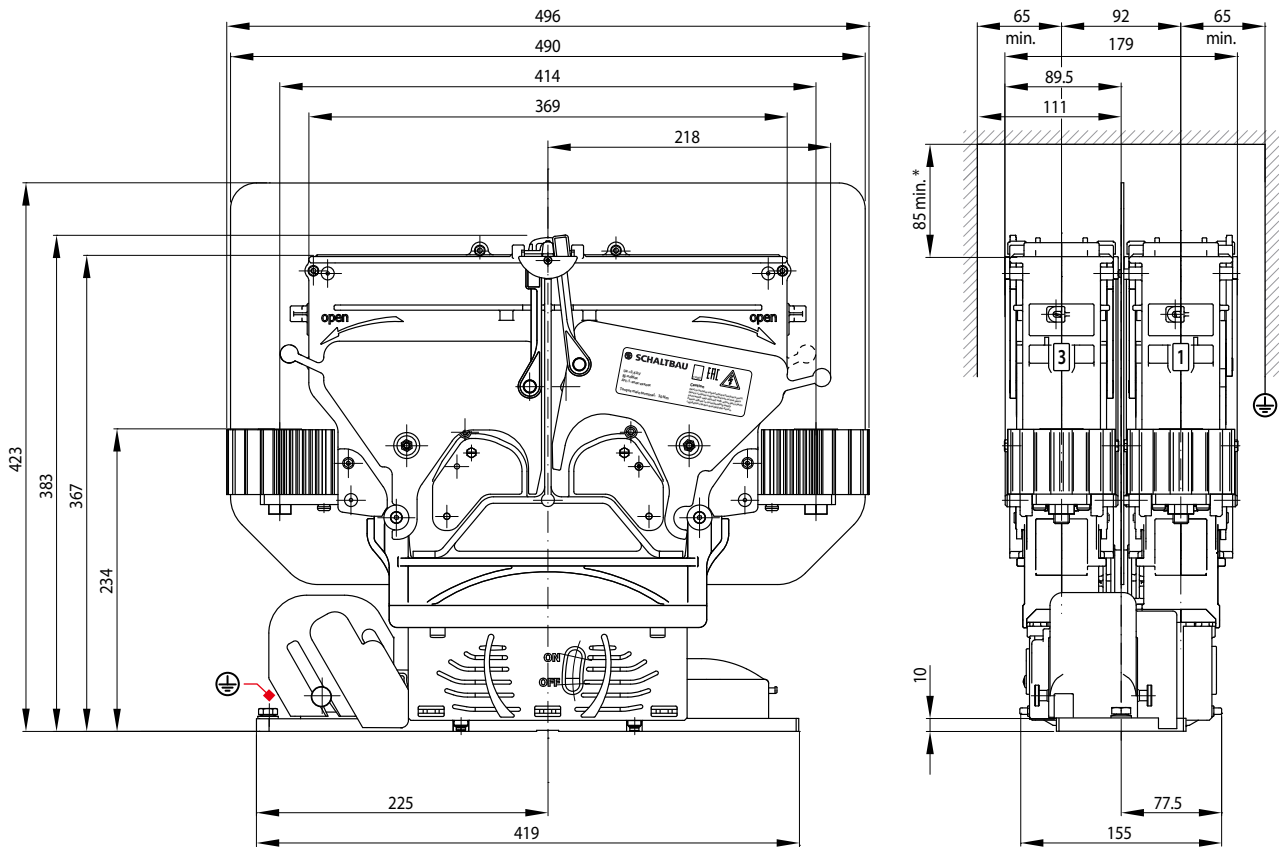

\* Interrupting at maximum capacity could require larger clearance!  
 Feel free to contact us, we will be happy to assist you with dimensioning.

**Mounting holes**

CT series

- Double pole NO contactor, CT1215/04, CT1230/04 series

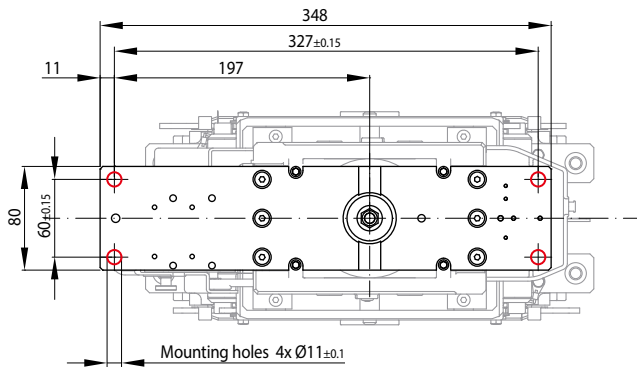

- Double pole NO contactor, CT1215/08, CT1230/08 series

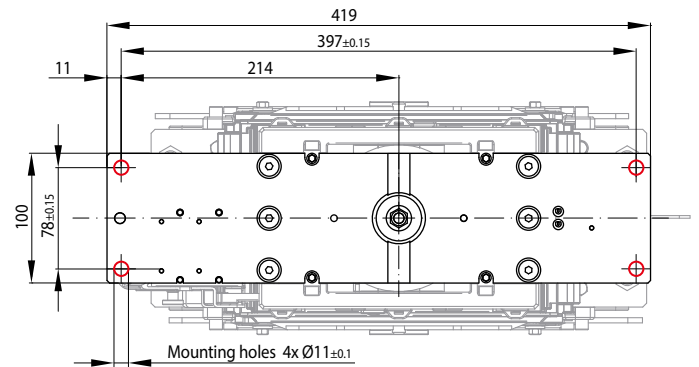

- Double pole NO contactor, CT1215/11, CT1230/11 series

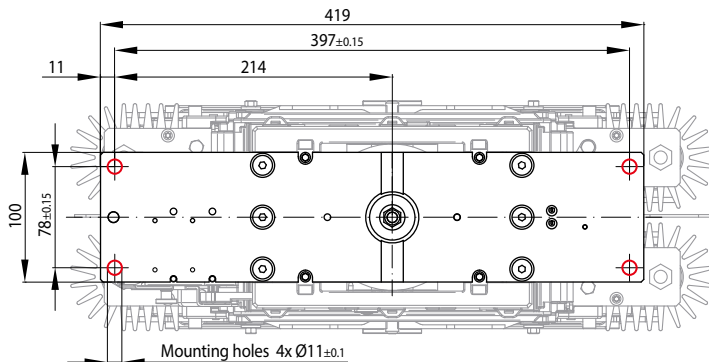

Mounting plate: bottom view

The thickness of the mounting plate is:

- CT1215/04, CT1230/04: 8 mm
- CT1215/08, CT1230/08: 10 mm
- CT1215/11, CT1230/11: 10 mm

**Mounting instructions**

CT series

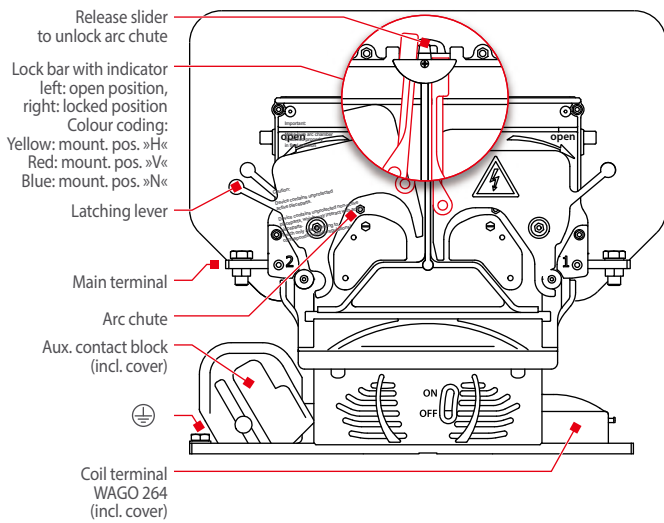

**Start up**

Before initial start up make sure that:

- the arc chute is mounted properly and the lock bars are locked in position
- the protective covers are mounted properly
- the contactor is earthed (PE terminal on mounting plate)

**Coil suppression**

Coil suppression »T«, suppressor diode: Coil suppression for reducing surges when the coil is switched off is optimally attuned to the contactor's switching behaviour. Caution: Parallel connection with a simple diode will override the existing coil suppression.

**Taking off the arc chute:**

1. Push both release sliders in the direction indicated by the arrow and hold them in this position.
2. Move all four levers for unlocking the arc chute in the direction indicated by the arrow.
3. The arc chute incorporating the stationary main contacts can now be lifted from the contactor.

**Mounting the arc chute:**

1. Mount the arc chute onto the magnetic drive. Note: The arc chute has keys on one side to fit into slots on the corresponding side of the contactor. So you cannot mount it the wrong way round.
2. Move all four levers for unlocking the arc chute into the original position.
3. Check: The arc chute is locked properly, if all four lock bars click into place and cannot be opened without pushing the release slider.

**Disassembly of protective covers:**

- Protective cover auxiliary switches: Dismount arc chute first, then loosen knurled head screws and remove protective cover.
- Protective cover coil terminals: Unscrew cover and take it off.

**Assembly of protective covers:**

- Protective cover auxiliary switches: Position protective cover and screw in both knurled head screws. Then mount arc chute.
- Protective cover coil terminals: Introduce protective cover into the groove of the coil drive and locate in position. Then tighten screws.

**Dimensioning instructions**

- Do you need some help? For selecting the contactor that suits your application best do not hesitate to ask our advice.
- For connection of the main contacts Schaltbau recommends the use of busbars with the following dimensioning:
  - Conv. thermal current  $I_{th} = 400 \text{ A}$ : 60 x 5 mm
  - Conv. thermal current  $I_{th} = 800 \text{ A}$ : 80 x 8 mm
- Observe clearance of live parts to arc chute! Refer to dimension drawings on page 4 and 5 for data.
- For high switching loads at  $U_n \geq 3,000 \text{ V DC}$  a special design CT1130/08 ... 200 with adjusted blow-out coils is available.

**Spare parts**

CT series

Items	Spare part, description	Ordering code					
		CT1215/04	CT1230/04	CT1215/08	CT1230/08	CT1215/11	CT1230/11
1	Stationary contact, complete – order 2 per pole	MC CT1015/04	MC CT1030/04	MC CT1015/08	MC CT1030/08	MC CT1015/11	MC CT1030/11
1	Insulation plate	IP CT1015/04	IP CT1030/04	IP CT1015/08	IP CT1030/08	IP CT1015/08	IP CT1030/08
1	Contact bridge with mounted contact holder, mounting position »H«	CBH CT1015/04	CBH CT1030/04	CBH CT1015/08	CBH CT1030/08	CBH CT1015/08	CBH CT1030/08
1	Contact bridge with mounted contact holder, mounting position »V«	CBV CT1015/04	CBV CT1030/04	CBV CT1015/08	CBV CT1030/08	CBH CT1200/08	
1	Ceramic protection inserts – order 2 per pole	PI CT1030/04		PI CT1000/08			
1	Protective cover coil terminals	CC CT1030/04		CC CT1030/08			
1	Protective cover aux. switches	CA CT1030/04		CA CT1030/08			
1	Snap-action switch (SPDT)	S826 a L					
1	Contact block of 2x S870 (momentary switches a1, b0)	AS S870					

⚠ When ordering spare parts, please always give the exact series as well as the article number of the contactor, see type plate.

## Mounting positions

CT series

The colour of the lock bars is an indication of the correct mounting position:

- H** **Horizontal:** Yellow lock bars ► Mounting position »H«
- V** **Vertical:** Red lock bars ► Mounting position »V«
- N** **Horizontal/vertical:** Blue lock bars ► Mounting position »H« or »V«

### Horizontal mounting:

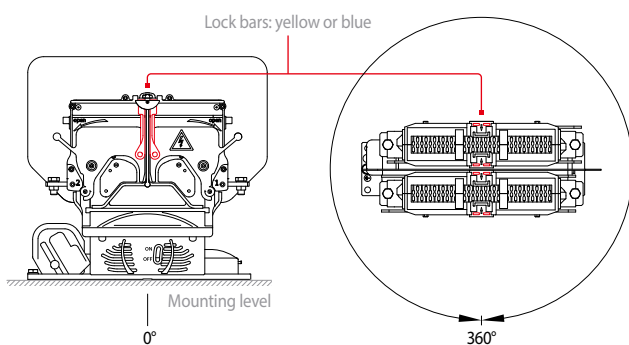

### Vertical mounting:

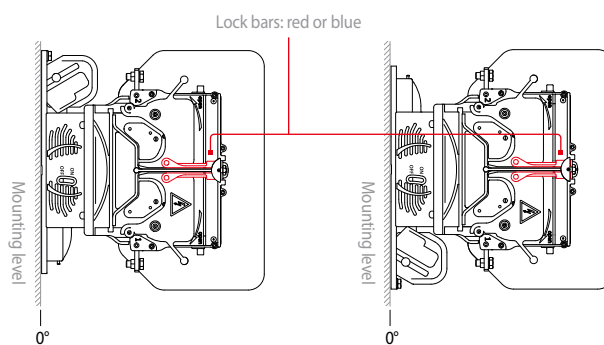

#### Mounting position:

Please observe the mounting position as shown on the nameplate.  
The permissible installation position can be recognized by the color of the lock bar.

## Maintenance instructions



**For detailed maintenance, safety and mounting instructions please refer to our operating manual**  
➔ [C20-C21-M.en!](#)

- CT series contactors are maintenance free with normal use.
- Make regular inspections once or twice a year. So when installing the contactor, make sure that there is enough space to remove and replace the arc chute with ease and that the main contacts become accessible for inspection.
- Frequent switching or switching under high load may lead to increased wear of the main contacts. In this case replacement of the main contacts may become necessary. For detailed information please refer to our manual.

## Safety instructions

CT series

- The switching device meets the requirements of basic insulation. Make sure the plate onto which the drive of the contactor is mounted is earthed in a vibration resistant way.
- Do not use contactor without properly mounted arc chute.
- The contactor has unprotected live parts and carries a label that warns of the hazard. This caution must be observed and the label must not be removed in any way.
- The required clearance of live parts to ground and other parts of the contactor is to be observed as well as the safety regulations of the applicable standards.
- Switching at maximum breaking capacity might require larger clearance! Do not hesitate to ask our advice for dimensioning.
- Do not use contactor without protective covers (for coil terminals and auxiliary switches).
- Coil suppression for reducing surges when the coil is switched off is optimally attuned to the contactor's switching behaviour. The existing opening characteristic must not be negatively influenced by parallel connection with an external diode.
- Improper handling of the contactor, e.g. when hitting the floor with some impact, can result in breakage, visible cracks and deformation.



**Defective parts must be replaced immediately!**

# Schaltbau GmbH

For detailed information on our products and services visit our website – or give us a call!

Schaltbau GmbH  
Hollerithstrasse 5  
81829 Munich  
Germany



Phone +49 89 9 30 05-0  
Fax +49 89 9 30 05-350  
Internet [www.schaltbau.com](http://www.schaltbau.com)  
e-Mail [contact@schaltbau.de](mailto:contact@schaltbau.de)

with compliments:



The production facilities of Schaltbau GmbH have been IRIS certified since 2008.



Certified to DIN EN ISO 14001 since 2002. For the most recent certificate visit our website.



Certified to DIN EN ISO 9001 since 1994. For the most recent certificate visit our website.

## Electrical Components and Systems for Railway Engineering and Industrial Applications

### Connectors

- Connectors manufactured to industry standards
- Connectors to suit the special requirements of communications engineering (MIL connectors)
- Charging connectors for battery-powered machines and systems
- Connectors for railway engineering, including UIC connectors
- Special connectors to suit customer requirements

### Snap-action switches

- Snap-action switches with positive opening operation
- Snap-action switches with self-cleaning contacts
- Snap-action switch made of robust polyetherimide (PEI)
- Snap-action switch with two galvanically isolated contact bridges
- Special switches to suit customer requirements

### Contactors Emergency disconnect switches

- Single and multi-pole DC contactors
- High-voltage AC/DC contactors
- Contactors for battery powered vehicles and power supplies
- Contactors for railway applications
- Terminal bolts and fuse holders
- DC emergency disconnect switches
- Special contactors to suit customer requirements

### Electrics for rolling stock

- Equipment for driver's cab
- Equipment for passenger use
- High-voltage switchgear
- High-voltage heaters
- High-voltage roof equipment
- Equipment for electric brakes
- Design and engineering of train electrics to customer requirements