

3

Contactors

CPP Series

1 pole
AC and uni-directional DC
NO and NC contactors

Catalogue C45.en

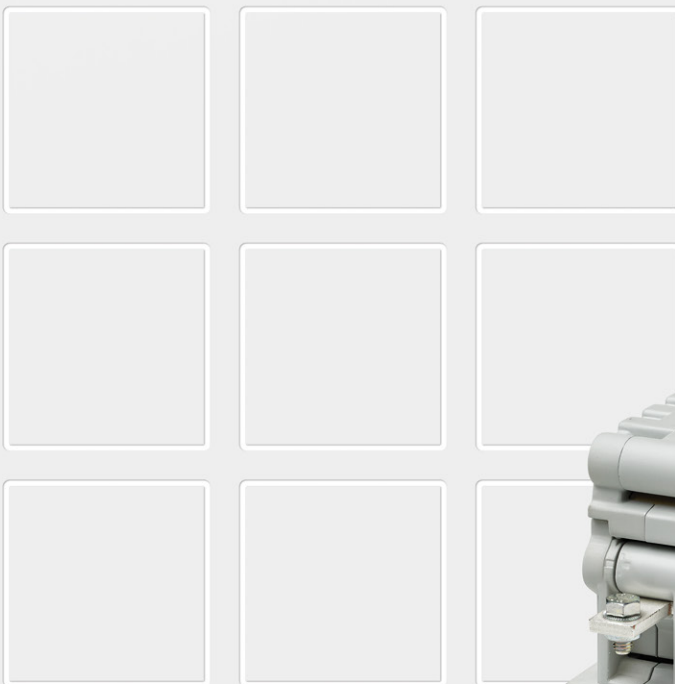

More information
schaltbau.com

CPP – 1-pole NO or NC contactors for DC or AC

Compact single-pole NO and NC contactors up to 3,600 volts rated insulation voltage. Making current up to 2,000 amps; conventional thermal current up to 200 amps; short-time currents up to 2,000 amps.

The super-compact DC contactors of the CPP series are the smallest Schaltbau switching devices in the power class up to 200 amps and suitable for rated operating voltages up to 3,000 volts. The single-pole switching devices are available as NO or NC contactors.

They are used in main and auxiliary converters of railway vehicles, but also in converters and inverters in the field of renewable energies or, more generally, in industrial environments.

Features

CPP series

- 

Compact dimensions – high rated insulation voltage U_{Nm} up to 3,600 volts
Small dimensions – great performance! All air gaps in the contact area are generously dimensioned. The rated insulation voltage is 3,600 volts for OV2 and 3,000 volts for OV3. A highly efficient ceramic arc chamber with permanent magnetic blow-out is used to handle arcs.
- 

High short-time withstand current rating I_{cw} of up to 2,000 amps
For 100 milliseconds, the normally open contact can carry a maximum current of 2,000 amps. The short-circuit current carrying capacity of the NC contact is 1,800 amps. This time is sufficient to trigger the short-circuit protection and prevent welding of the main contacts. The short-time current carrying capacity is supported by high contact forces and optimised silver contacts.
- 

High making capacity I_{cm} of up to 2,000 amps
The CPP can switch on currents of up to 2,000 amps in the make contactor version. In the version as a break contactor, up to 850 amps. High contact forces and optimised silver contacts favour the excellent breaking capacity.
- 

Auxiliary contacts with snap-action switches
Two S870 series auxiliary switches are optionally available for extensive diagnostics and switching condition monitoring. The switches have robust silver or gold contacts.
- 

High thermal continuous current I_{th} of up to 200 amps
The CPP series can permanently carry currents of up to 200 amps in the NO contactor version. In the version as a NC contactor, currents of 120 amps can be carried. Connection cross-section: NO contactor 120 mm², NC contactor 35 mm², maximum ambient temperature: 70 °C. The values are achieved through high contact forces.

Standards

CPP series

- 

IEC 60077-1:2002
Railway applications – Electric equipment for rolling stock – Part 1: General service conditions and general rules
- 

IEC 60947-4-1:
Low-voltage switchgear and controlgear – Part 4-1: Contactors and motor-starters – Electromechanical contactors and motor-starters
- 

IEC 60077-2:2002
Railway applications – Electric equipment for rolling stock – Part 2: Electrotechnical components – General rules
- 

UL 60947-4-1
Low-Voltage Switchgear and Controlgear – Part 4-1: Contactors and Motor-Starters – Electromechanical Contactors and Motor-Starters.
- 

IEC 62497-1:
Railway applications – Insulation coordination – Part 1: Basic requirements – Clearances and creepage distances for all electrical and electronic equipment
- 

GB/T 14048.4
Low-Voltage Switchgear and Controlgear – Part 4-1: Contactors and Motor-Starters – Electromechanical Contactors and Motor-Starters.
- 

IEC 61373:
Railway applications – Rolling stock equipment – Shock and vibration tests

Reliable, robust and economical

CPP series

Contactors of the CPP series are designed for continuous currents up to 200 A. Among other features, the robust switchgear has a high breaking and breaking capacity as well as a high short-time rated current. This ensures long operational reliability. Depending on the application,

different requirements are placed on electromechanical components. The new DC contactors are very robust against shock and vibration loads and meet the requirements of IEC 60077.

Application

CPP series

Thanks to many years of experience and expertise in the development of electromechanical switchgear and the control of arcs, especially DC arcs, Schaltbau has a compact contactor for high rated insulation voltages in its range with the CPP series. The device, which is available as a NO or NC contactor, is suitable as a precharging contactor for the large Schaltbau CP and CT series. It can also be used as a universal contactor.

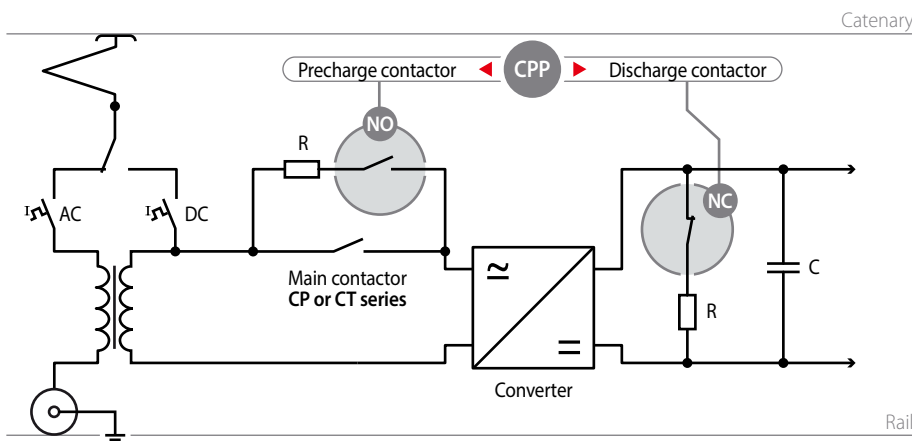

- NO Precharging NO contactor**
Use as a classic precharging contactor in the make contact variant: connecting and disconnecting the resistor for precharging the DC link in converters of railway vehicles.
- NC Discharging NC contactor**
Use as discharge contactor in the NC contact variant: discharging the capacitor in the DC link in converters of railway vehicles or in industrial test systems.
- Universal contactor**
NO or NC contactor for switching single-pole loads for small and medium switching capacities.

Ordering key

CPP series

Example: **CPP1115-02-C-2**

Series, contact configuration

CPP11	1 pole AC and uni-directional DC NO contactor
CPP21	1 pole AC and uni-directional DC NC contactor

Nominal voltage

15	1,500 V
----	---------

Conv. thermal current

01	$I_{th} = 120 \text{ A}^*$, CPP21 only (DC NC contactor)
02	$I_{th} = 200 \text{ A}^*$, CPP11 only (DC NO contactor)

Coil voltage

A	$U_s = 24 \text{ V DC}$
B	$U_s = 36 \text{ V DC}$
C	$U_s = 48 \text{ V DC}$
D	$U_s = 60 \text{ V DC}$
E	$U_s = 72 \text{ V DC}$
F	$U_s = 84 \text{ V DC}$
G	$U_s = 96 \text{ V DC}$
H	$U_s = 110 \text{ V DC}$

Auxiliary switches, number / type

---	0
2x / Snap-action switch S870, change-over, silver contacts, terminals 45° angled	1
2x / Snap-action switch S870, change-over, silver contacts, terminals straight	2

Note:
Presented in this catalogue are only stock items which can be supplied in short delivery time. For some variants minimum quantities apply. Please do not hesitate to ask for the conditions. Special variants:
If you need a special variant of the contactor, please do not hesitate to contact us. Maybe the type of contactor you are looking for is among our many special designs. If not, we can also supply customized designs. In this case, however, minimum order quantities apply.

* For IEC/UL 60947-4-1 and GB/T 14048.4 the values as given in the table "Technical data" apply.

Specifications CPP1115-02, CPP2115-01

CPP series

Series		CPP1115-02	CPP2115-01
Type of voltage		DC, uni-directional / AC, f ≤ 60 Hz	
Main contacts, configuration		1x NO	1x NC
Electrical data according to IEC 60077-2			
Nominal voltage	U _n	1,500 V	
Rated operational voltage	U _e	1,800 V	
Rated insulation voltage	U _{Nm}	3,000 V @ PD3, OV3 / 3,600 V @ PD2, OV2	
Rated impulse withstand voltage	U _{Ni}	15 kV	
Pollution degree / Overvoltage category		PD3 or PD2 / OV3 or OV2 (see U _{Nm})	
Switching overvoltages	@ U _e = 1,800 V	<15 kV @ T2 = 15 ms	
Conventional free air thermal current I _{th}	T _a = 70 °C (cross section) Terminal heating	200 A (120 mm ²) 40 K	120 A (35 mm ²) 30 K
Power dissipation per pole	I _{th} @ 20 °C, typ.	13.5 W	10 W
Pole impedance	typ.	350 μΩ	400 μΩ
Component category		B	B
Breaking capacity, 5 operations	DC, U _e = 750 V, t ≤ 0.15 ms DC, U _e = 1,500 V, t ≤ 0.5 ms DC, U _e = 3,000 V, t ≤ 0.3 ms DC, U _e = 960 V, t ≤ 15 ms DC, U _e = 1,500 V, t ≤ 15 ms AC, U _e = 750 V, cosφ = 0.9 AC, U _e = 1,200 V, cosφ = 0.9 AC, U _e = 1,500 V, cosφ = 0.9 AC, U _e = 3,000 V, cosφ = 0.9 AC, U _e = 3,000 V, cosφ = 0.8	1,100 A 250 A 50 A 100 A 50 A 400 A 400 A 300 A 130 A 50 A	1,100 A 250 A 50 A 100 A 50 A 400 A 400 A 300 A 130 A 50 A
Rated short-circuit making capacity	I _{cm} @ L/R = 0 ms	2,000 A	850 A
Rated short-time withstand current I _{cw}	t = 100 ms	2,000 A	1,800 A
Critical current range		None	None
Electrical data according to DIN EN IEC/UL 60947-4-1, GB/T 14048.4			
Rated operational voltage U _e		1,500 V	
Rated insulation voltage U _i		1,500 V	
Rated impulse withstand voltage U _{imp}		8 kV	
Pollution degree / Overvoltage category		PD3 / OV3	
Conventional free air thermal current I _{th}	T _a = 70° C (cross section)	160 A (50 mm ²)	50 A (10 mm ²)
Power dissipation per pole I _{th}	typ.	13.5 W	10 W
Pole impedance	typ.	350 μΩ	400 μΩ
Utilization category DC-1		15 A @ U _e = 1,500 V DC	
Rated operational current I _e	IEC 60947-4-1, GB/T 14048.4	15 A @ U _e = 1,500 V DC	
Utilization category DC-1 / DC general use		15 A @ U _e = 1,500 V DC	
Rated operational current I _e	UL 60947-4-1	15 A @ U _e = 1,500 V DC	
Frequency of operation (operations per hour) I _e	DC-1	360 h ⁻¹	
Rated short-time withstand current I _{cw}	t = 100 ms	2,000 A	1,800 A
Main contacts			
Contact material		AgSnO ₂	
Terminals		M5	
Torque		4 ... 5 Nm	
Auxiliary contacts			
Number, configuration / Contact material		2x SPDT (S870 W1D1 a) / Silver 2x SPDT (S870 W1D4 a) / Gold	
Switching capacity	SPDT S870 W1D1 a, silver SPDT S870 W1D4 a, gold	AC-15: 230 V AC / 1.5 A AC-15: 230 V AC / 1.0 A	DC-13: 60 V DC / 0.5 A DC-13: 60 V DC / 0.5 A
Minimum voltage / Minimum current	SPDT S870 W1D1 a, silver SPDT S870 W1D4 a, gold	24 V / 5 mA 24 V / 1 mA	
Terminals		Flat tabs 6.3 x 0.8 mm	
Magnetic drive (monostable)			
Coil voltage U _s / Coil tolerance		24 / 36 / 48 / 60 / 72 / 84 / 96 / 110 V DC / -30 % ... +25 %	
Pollution degree / Overvoltage category		PD3 / OV2	
Coil power dissipation, max. (T _a = 20 °C / U _s)	cold coil / warm coil	approx. 30 W @ U _s / approx. 23.5 W @ U _s	
Frequency of operation (operations per hour, no load)	T _a = 20 °C / 70 °C	3,600 h ⁻¹ / 1,800 h ⁻¹	
Pull-in time (T _a = 20 °C / U _s) / Drop-off time (T _a = 20 °C / U _s)	typ.	40 ms / 20 ms	30 ms / 50 ms
Coil suppression		Suppressor diode	
Coil terminal		Adels LK 980-01 RZ/2 for solid and fine-stranded conductors up to 2.5 mm ² max.	
Mounting position		vertical / horizontal (see assembly page 6)	
Degree of protection	IEC 60529	IP00	
Mechanical endurance		2,000,000 operations	
Shock / Vibration	IEC 61373	Category 1, Class B	
Temperatures	Operating temperature / Storage temperature Altitude / Humidity (IEC 62498-1)	-40 °C ... +70 °C / -40 °C ... +85 °C < 2,000 m above sea level / < 75 % yearly average	
Weight		1.3 kg	

Dimension diagram CPP1115/02 – 1 pole AC and uni-directional DC NO contactor

CPP series

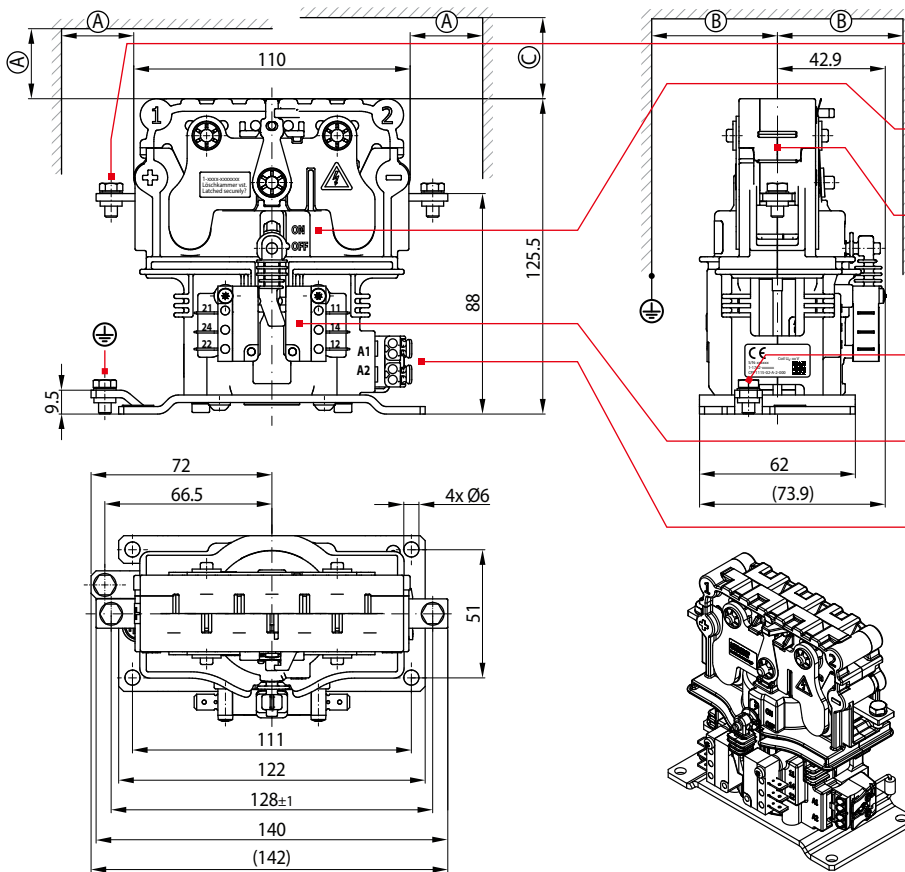

Main contact terminals
Screw M5, torque 4 ... 5 Nm

Switching state display
ON: Main contact system closed
OFF: Main contact system open

Arc chamber
Highly efficient ceramic arc chamber with permanent magnetic blowout

Earth terminal
Screw M5, torque 4 ... 5 Nm

Aux. switch group
2x S870, SPDT, flat tabs 6.3 x 0.8 mm

Coil terminal
2 pole screwless terminal block for solid and fine-stranded conductors up to 2.5 mm² max.

Dimension diagram CPP2115/01 – 1 pole AC and uni-directional DC NC contactor

CPP series

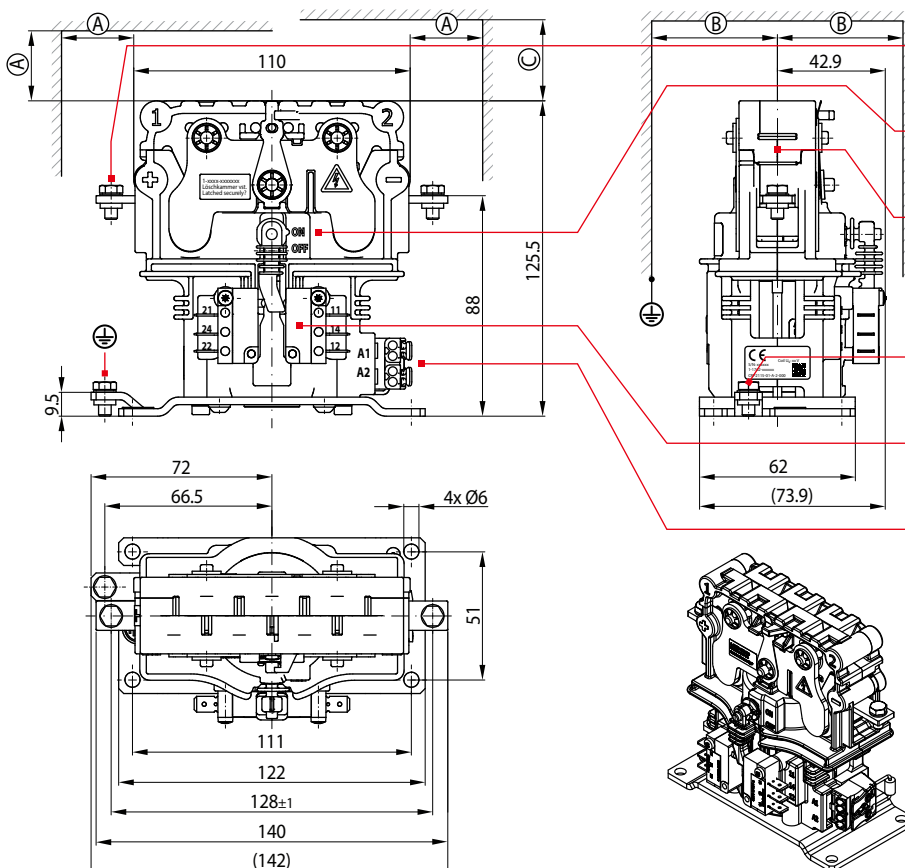

Main contact terminals
Screw M5, torque 4 ... 5 Nm

Switching state display
ON: Main contact system closed
OFF: Main contact system open

Arc chamber
Highly efficient ceramic arc chamber with permanent magnetic blowout

Earth terminal
Screw M5, torque 4 ... 5 Nm

Aux. switch group
2x S870, SPDT, flat tabs 6.3 x 0.8 mm

Coil terminal
2 pole screwless terminal block for solid and fine-stranded conductors up to 2.5 mm² max.

Minimum distances

To earth potential*	A	30 mm
	B	45 mm
To insulating structure*	A	20 mm
	B	40 mm
Arc chamber removal clearance	C	30 mm

* defined for max. breaking capacity

Circuit diagrams

CPP series

• **NO contactor**

CPP1115/02 X*0

Main contact
1x NO
Number of auxiliary switches
none



• **NC contactor**

CPP2115/01 X*0

Main contact
1x NC
Number of auxiliary switches
none



CPP1115/02 X*2

Main contact
1x NO
Number of auxiliary switches
2x SPDT S870

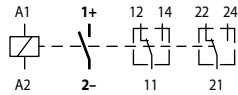

CPP2115/01 X*2

Main contact
1x NC
Number of auxiliary switches
2x SPDT S870

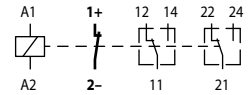

X* Coil voltage A=24V B=36V C=48V D=60V E=72V G=84V H=110V,
see ordering key on page 3

Mounting instructions

CPP series

• **Permissible mounting orientations**

CPP1115/02 series

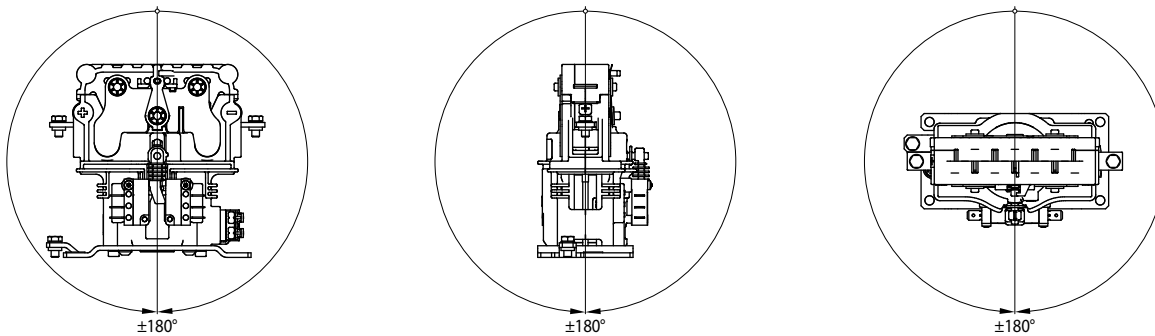

CPP2115/01 series

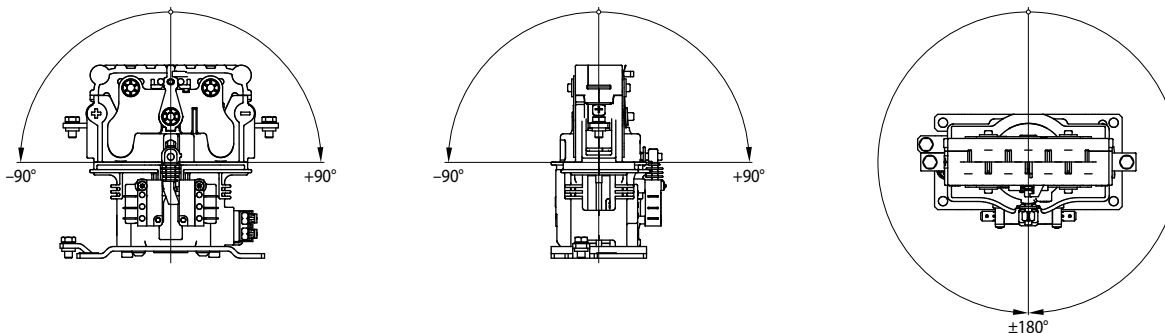

Horizontal assembly
"Table mounting"

Horizontal assembly
"Table mounting"

Vertical assembly
"Wall mounting"

• **Mounting holes**

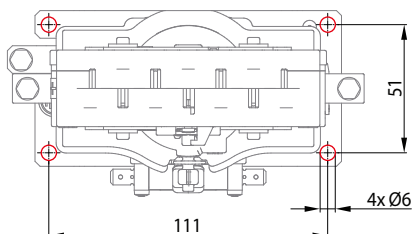

The contactors are mounted on a mounting plate with four M5 screws.

Maintenance and safety instructions

CPP series

Maintenance:

- CPP series contactors are basically maintenance free.
- Make regular in-depth visual inspections once or twice a year.

Safety instructions:

- The device must be used according to the intended purpose as specified in the technical documentation. You are obliged to observe all specifications depending on operating temperature, degree of pollution etc. that are relevant to your application.
- Without further safety measures the contactors are not suited for use in potentially explosive atmospheres.
- In case of malfunction of the device or uncertainties stop using it any longer and contact the manufacturer instantly.
- Tampering with the device can seriously affect the safety of people and equipment. This is not permitted and leads to an exclusion of liability and warranty.
- Coil suppression for reducing surges when the coil is switched off is optimally attuned to the contactors switching behaviour. The existing opening characteristic must not be negatively influenced by parallel connection with an external diode.
- Contactors running permanently may heat up. So make sure that the contactor has sufficiently cooled down before you start any inspection or maintenance work.
- When installing contactors with magnetic blowout make sure to do it in such a way that no magnetizable parts can be attracted by the permanent magnets that are also capable of destroying all data of swipe cards.
- Strong electromagnetic induction caused when switching off can influence other components installed near the contactor.
- Improper handling of the contactor, e.g. when hitting the floor with some impact, can result in breakage, visible cracks and deformation.



For detailed maintenance, safety and mounting instructions please refer to our operating manuals
➔ [C45-M.en!](#)



Defective contactors or parts (e.g. arc chambers, auxiliary switches) must be replaced immediately!

Schaltbau GmbH

For detailed information on our products and services visit our website – or give us a call!

Schaltbau GmbH
Hollerithstrasse 5
81829 Munich
Germany



Phone +49 89 9 30 05-0
Fax +49 89 9 30 05-350
Internet www.schaltbau.com
e-Mail contact@schaltbau.de



The production facilities of Schaltbau GmbH have been IRIS certified since 2008.



Certified to DIN EN ISO 14001 since 2002. For the most recent certificate visit our website.



Certified to DIN EN ISO 9001 since 1994. For the most recent certificate visit our website.

Electrical Components and Systems for Railway Engineering and Industrial Applications

Connectors

- Connectors manufactured to industry standards
- Connectors to suit the special requirements of communications engineering (MIL connectors)
- Charging connectors for battery-powered machines and systems
- Connectors for railway engineering, including UIC connectors
- Special connectors to suit customer requirements

Snap-action switches

- Snap-action switches with positive opening operation
- Snap-action switches with self-cleaning contacts
- Snap-action switch made of robust polyetherimide (PEI)
- Snap-action switch with two galvanically isolated contact bridges
- Special switches to suit customer requirements

Contactors Emergency disconnect switches

- Single and multi-pole DC contactors
- High-voltage AC/DC contactors
- Contactors for battery powered vehicles and power supplies
- Contactors for railway applications
- Terminal bolts and fuse holders
- DC emergency disconnect switches
- Special contactors to suit customer requirements

Electrics for rolling stock

- Equipment for driver's cab
- Equipment for passenger use
- High-voltage switchgear
- High-voltage heaters
- High-voltage roof equipment
- Equipment for electric brakes
- Design and engineering of train electrics to customer requirements