

**Fuses
for high-voltage
switchgear
F-HS, F-VS Series**

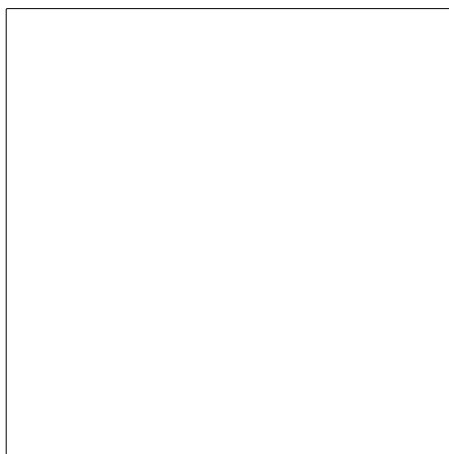
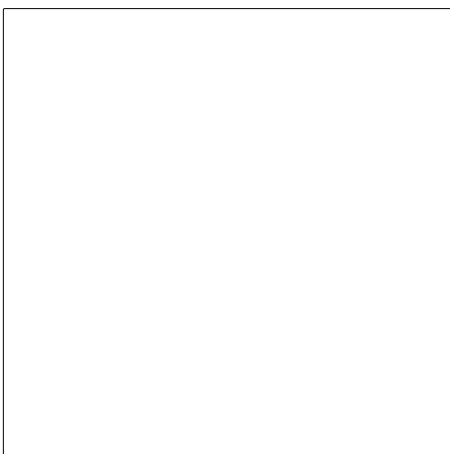
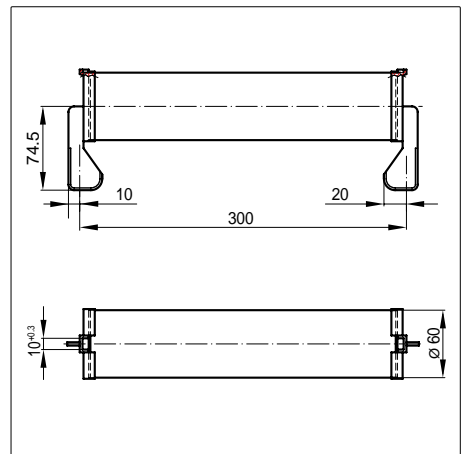
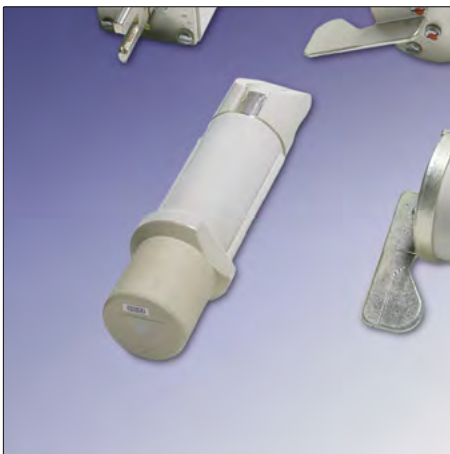
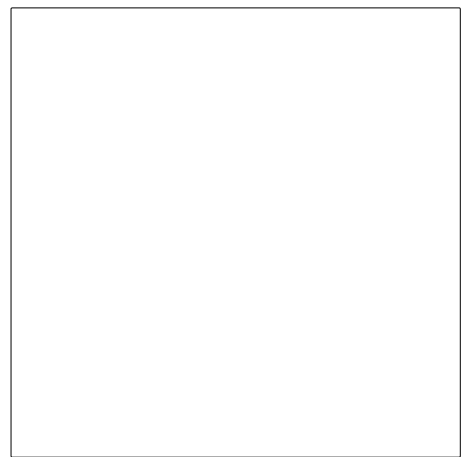

Fuses for high-voltage switchgear, F-HS and F-VS Series

For the protection of high-voltage switchgear Schaltbau offers a complete range of high-voltage fuses and fuse holders. The series-connected fuses provide failsafe surge protection for the downstream equipment in every situation. This is true for short circuits and also for overcurrents exceeding five times the value of the nominal current ($5 \times I_{nom}$).

F-HS Series fuses are main fuses designed for nominal currents of 7.5 A up to 125 A, whereas F-VS Series fuses are distribution fuses designed for nominal currents of 3 A up to 16 A.

F-HS and F-VS Series fuses are available for the following voltage ranges:

- 1 kV AC and 1 kV DC
- 1.5 kV AC and 1.5 kV DC
- 3 kV AC and 3 kV DC
- 5 kV DC

This range of fuses covers all existing train line voltages of the European railway systems.

Features

- Compact design
- 4 different sizes
- Fuses designed for 5 kV DC
- Standards: UIC 550, EN 50163, and IEC 60077-5

Applications

- Main fuses for power supplies of rail vehicles, e.g. electric equipment and heating system
- Distribution fuses for branch circuits

Ordering code

• Distribution fuses

Example: **F-VS1-10-0100**

Series	F-VS	Distribution fuse
Size	1 ... 2	Fuse sizes, see page 4
Nominal voltage*	10	1,000 V AC
	30	3,000 V DC
Nominal current*	0020	2 A
	0030	3 A
	0040	4 A
	0060	6 A
	0100	10 A
	0120	12 A
	0160	16 A

• Main fuses

Example: **F-HS1-10-0400**

Series	F-HS	Main fuse
Size	1 ... 8	Fuse sizes, see page 3
Nominal voltage*	10	1,000 V AC
	15	1,500 V DC / 1,500 V AC
	30	3,000 V DC / 3,000 V AC
	50	5,000 V DC / 3,000 V AC
Nominal current*	0075	7.5 A
	0100	10 A
	0160	16 A
	0200	20 A
	0250	25 A
	0300	30 A
	0350	35 A
	0400	40 A
	0500	50 A
	0600	60 A
	0700	70 A
	1250	125 A

• Fuse holders for main fuses

Example: **F-HS1 SH-S**

Series	F-HS	Main fuse
Size	1, 2, 4, 6, 8	Fuse sizes, see page 6
Designation	SH	Fuse holder
	SH-S	Fuse holder with safety catch, only for 5,000 V fuses

• Fuse holders for distribution fuses

Example: **F-VS1 SH-03/06**

Series	F-VS	Distribution fuse
Size	1, 2	Fuse sizes, see page 6
Designation	SH	Fuse holder
Shim plates	02	2 A
	06	6 A
	03/06	3 A and 6 A
	10	10 A
	04/12	4 A and 12 A
	16/20	16 A and 20 A

• Shim plates for distribution fuses

Example: **F-VS1 P-03/06**

Series	F-VS	Distribution fuse
Size	1 ... 2	Fuse sizes, see page 7
Designation	P-02	2 A
	P-06	6 A
	P-03/06	3 A and 6 A
	P-10	10 A
	P-04/12	4 A and 12 A
	P-16/20	16 A and 20 A

F-VS1-10-yyyy, F-VS2-30-yyyy Distribution fuses

F-VS

- **Size 1,**
Distribution fuses F-VS1

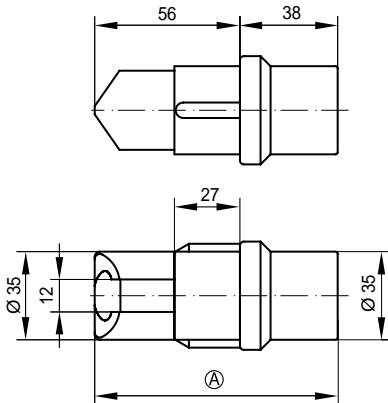

Plan view with key positions

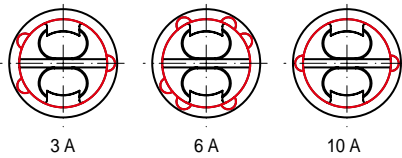

- **Size 2,**
Distribution fuses F-VS2

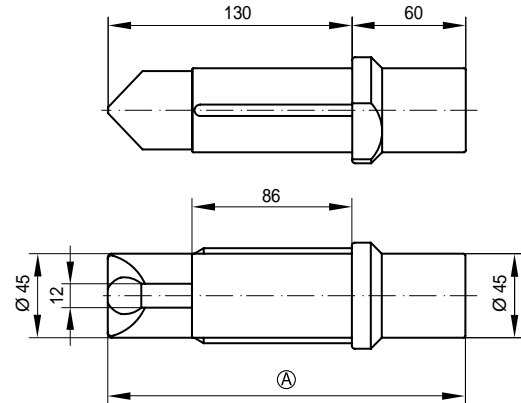

Plan view with key positions

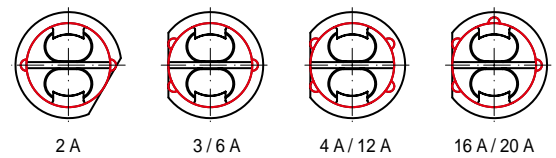

- **Distribution fuses F-VS1-10-yyyy (size 1)**

Ordering code	Height \AA in [mm]	Diameter in [mm]	U_{nom} in [V]	I_{nom} in [V]
F-VS1-10-0060	94	42	1,000	6
F-VS1-10-0100	94	42	1,000	10

- **Distribution fuses F-VS2-30-yyyy (size 2)**

Ordering code	Height \AA in [mm]	Diameter in [mm]	U_{nom} in [V]	I_{nom} in [V]
F-VS2-30-0020	190	45	3,000	2
F-VS2-30-0030	190	45	3,000	3
F-VS2-30-0040	190	45	3,000	4
F-VS2-30-0060	190	45	3,000	6
F-VS2-30-0120	190	45	3,000	12
F-VS2-30-0160	190	45	3,000	16

Time/current characteristics Distribution fuses

F-VS

- **Distribution fuses, F-VS Series**
Time/current characteristics 1.0 kV

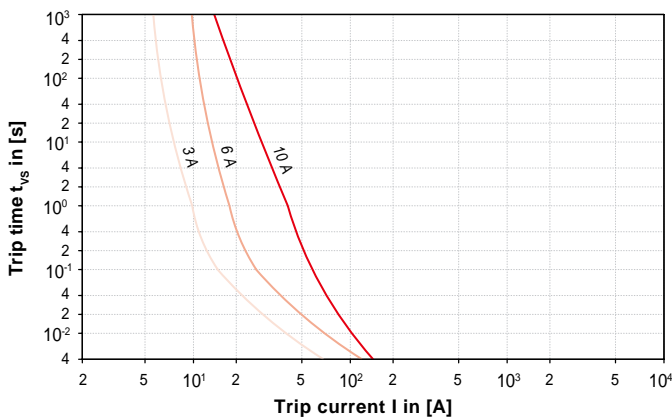

- **Distribution fuses, F-VS Series**
Time/current characteristics 3.0 kV

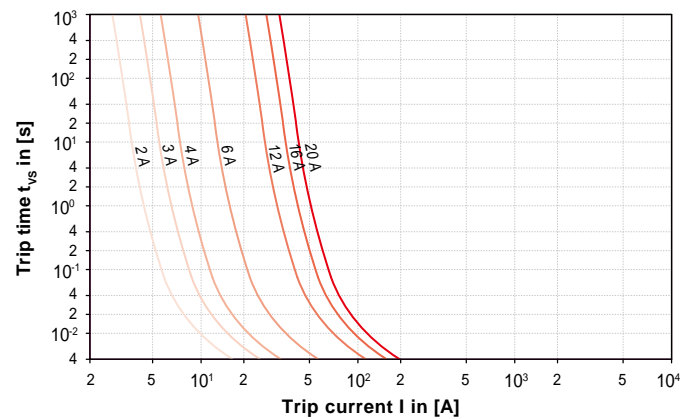

F-HS1...8-xx-yyyy Main fuses

F-HS

- Size 1, 2, 3 and 5: Main fuses F-HS1 / 2 / 3 / 5

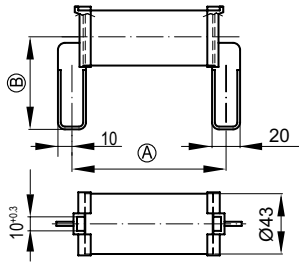

- Size 4, 6 and 7: Main fuses F-HS4 / 6 / 7

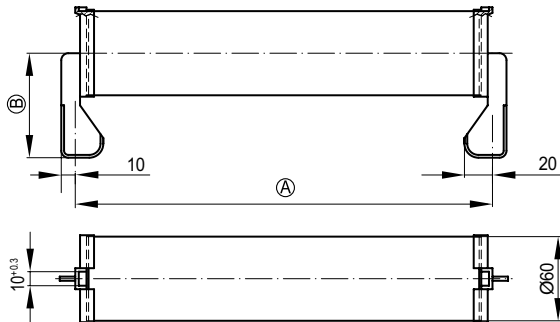

- Main fuses F-HS1-10-yyyy (size 1)

Ordering code	Length ^(A) in [mm]	Height ^(B) in [mm]	Ø in [mm]	U _{nom} in [V]	I _{nom} in [A]
F-HS1-10-0075	110	61	32	1,000	7.5
F-HS1-10-0100	110	61	32	1,000	10
F-HS1-10-0160	110	61	32	1,000	16
F-HS1-10-0200	110	61	32	1,000	20
F-HS1-10-0250	110	61	32	1,000	25
F-HS1-10-0300	110	61	32	1,000	30
F-HS1-10-0350	110	61	32	1,000	35
F-HS1-10-0400	110	61	32	1,000	40

- Main fuses F-HS2-10-0500 (size 2)

Ordering code	Length ^(A) in [mm]	Height ^(B) in [mm]	Ø in [mm]	U _{nom} in [V]	I _{nom} in [A]
F-HS2-10-0500	110	66	43	1,000	50

- Main fuses F-HS3-xx-yyyy (size 3)

Ordering code	Length ^(A) in [mm]	Height ^(B) in [mm]	Ø in [mm]	U _{nom} in [V]	I _{nom} in [A]
F-HS3-10-0600	170	66	43	1,000	60
F-HS3-15-0075	170	66	43	1,500	7.5
F-HS3-15-0200	170	66	43	1,500	20
F-HS3-15-0300	170	66	43	1,500	30

- Main fuses F-HS4-10-0700 (size 4)

Ordering code	Length ^(A) in [mm]	Height ^(B) in [mm]	Ø in [mm]	U _{nom} in [V]	I _{nom} in [A]
F-HS4-10-0700	170	74.5	60	1,000	70

- Size 8: Main fuses F-HS8

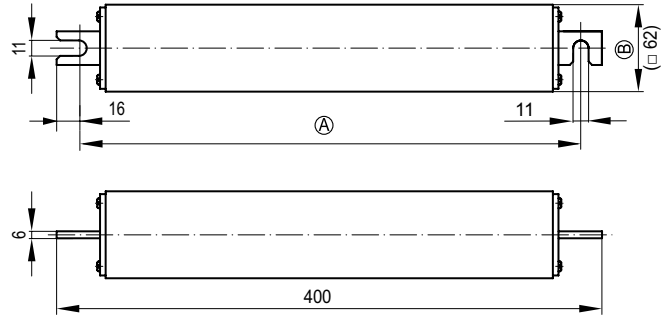

- Main fuses F-HS5-xx-yyyy (size 5)

Ordering code	Length ^(A) in [mm]	Height ^(B) in [mm]	Ø in [mm]	U _{nom} in [V]	I _{nom} in [A]
F-HS5-15-0500	250	66	43	1,500	50
F-HS5-15-0600	250	66	43	1,500	60
F-HS5-30-0100	260	66	43	3,000	10
F-HS5-30-0150	260	66	43	3,000	15
F-HS5-30-0300	260	66	43	3,000	30
F-HS5-30-0500	260	66	43	3,000	50

- Main fuses F-HS6-xx-yyyy (size 6)

Ordering code	Length ^(A) in [mm]	Height ^(B) in [mm]	Ø in [mm]	U _{nom} in [V]	I _{nom} in [A]
F-HS6-10-1000	300	74.5	60	1,000	100
F-HS6-10-1250	300	74.5	60	1,000	125
F-HS6-30-0100	300	74.5	60	3,000	10
F-HS6-30-0200	300	74.5	60	3,000	20
F-HS6-30-0300	300	74.5	60	3,000	30
F-HS6-30-0400	300	74.5	60	3,000	40
F-HS6-30-0500	300	74.5	60	3,000	50
F-HS6-30-0600	300	74.5	60	3,000	60
F-HS6-30-0700	300	74.5	60	3,000	70

- Main fuses F-HS7-30-1000 (size 7)

Ordering code	Length ^(A) in [mm]	Height ^(B) in [mm]	Ø in [mm]	U _{nom} in [V]	I _{nom} in [A]
F-HS7-30-1000	350	74.5	60	3,000	100 A

- Main fuses F-HS8-50-yyyy (size 8)

Ordering code	Length ^(A) in [mm]	Height ^(B) in [mm]	Ø in [mm]	U _{nom} in [V]	I _{nom} in [A]
F-HS8-50-0200	368	62	62	5,000	20
F-HS8-50-0300	368	62	62	5,000	30
F-HS8-50-0700	368	62	62	5,000	70
F-HS8-50-1000	368	62	62	5,000	100

F-HSx SH-y, F-VSx SH-yy Fuse holders for main and distribution fuses

- Fuse holders F-HS1 SH, F-HS2 SH, F-HS4 SH and F-HS6 SH for main fuses F-HS1 ... 7-xx-yyyy

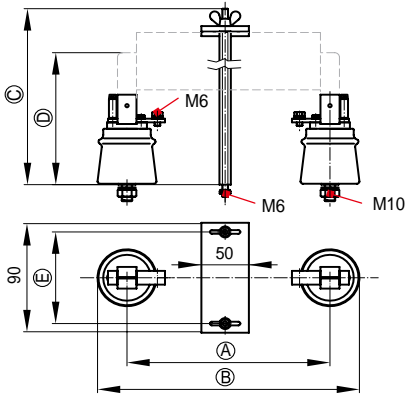

- Fuse holders F-HS8 SH and F-HS8 SH-S for main fuses F-HS8-50-yyyy

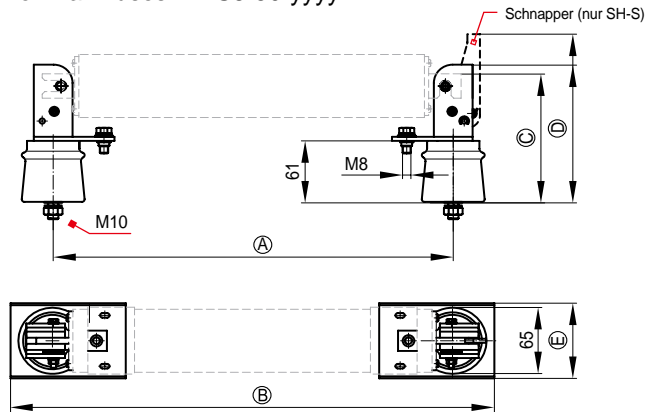

- Fuse holders F-VS1 SH-02, F-VS1 SH-06 and F-VS1 SH-10 for distribution fuses F-VS1 SH-yy

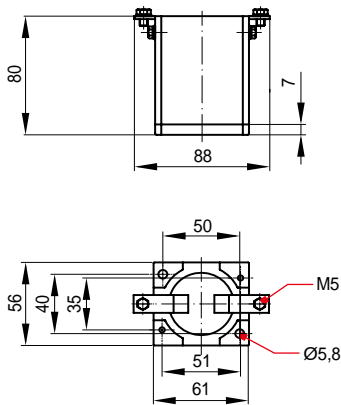

- Fuse holders F-VS2 SH-02, F-VS2 SH-03/06, F-VS2 SH-04/12 and F-VS2 SH-16/20 for distribution fuses F-VS2 SH-yy

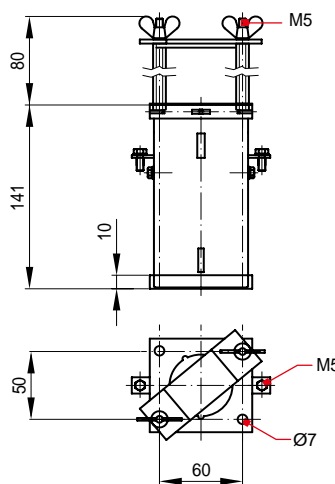

- Fuse holders for main fuses F-HSx SH

Ordering code	related main fuses	Length A in [mm]	Length B in [mm]	Height C in [mm]	Height D in [mm]	Width E in [mm]
F-HS1 SH	F-HS1-10-0075	110	172	188	142	70
	F-HS1-10-0100	110	172	188	142	70
	F-HS1-10-0160	110	172	188	142	70
	F-HS1-10-0200	110	172	188	142	70
	F-HS1-10-0250	110	172	188	142	70
	F-HS1-10-0300	110	172	188	142	70
	F-HS1-10-0350	110	172	188	142	70
	F-HS1-10-0400	110	172	188	142	70
	F-HS2 SH	F-HS2-10-0500	110	172	190	142
F-HS3-10-0600		170	232	190	142	100
F-HS3-15-0075		170	232	190	142	100
F-HS3-15-0200		170	232	190	142	100
F-HS3-15-0300		170	232	190	142	100
F-HS5-15-0500		250	312	190	142	100
F-HS5-15-0600		250	312	190	142	100
F-HS5-30-0100		250	312	190	142	100
F-HS5-30-0150		250	312	190	142	100
F-HS5-30-0300		250	312	190	142	100
F-HS5-30-0500	250	312	190	142	100	
F-HS4 SH	F-HS4-10-0700	170	232	207	152	100
F-HS6 SH	F-HS6-10-1000	300	362	208	152	100
	F-HS6-10-1250	300	362	208	152	100
	F-HS6-30-0100	300	362	208	152	100
	F-HS6-30-0200	300	362	208	152	100
	F-HS6-30-0300	300	362	208	152	100
	F-HS6-30-0400	300	362	208	152	100
	F-HS6-30-0500	300	362	208	152	100
	F-HS6-30-0600	300	362	208	152	100
	F-HS6-30-0700	300	362	208	152	100
	F-HS7-30-1000	350	412	208	152	100

- Fuse holders for main fuses F-HS8 SH-y

Ordering code	related main fuses	Length A in [mm]	Length B in [mm]	Height C in [mm]	Height D in [mm]	Width E in [mm]
F-HS8 SH	F-HS8-50-0200	382	462	131	136	74
	F-HS8-50-0300	382	462	131	136	74
	F-HS8-50-0700	382	462	131	136	74
	F-HS8-50-1000	382	462	131	136	74
F-HS8 SH-S	F-HS8-50-0200	382	462	131	167	74
	F-HS8-50-0300	382	462	131	167	74
	F-HS8-50-0700	382	462	131	167	74
	F-HS8-50-1000	382	462	131	167	74

- Fuse holders for distribution fuses F-VS1 SH-yy and F-VS2 SH-yy

Size	Ordering code	related distribution fuses	Fuse holder with gauge plate
F-VS1	F-VS1 SH-03	F-VS1-10-0030	F-VS1 P-03
	F-VS1 SH-06	F-VS1-10-0060	F-VS1 P-06
	F-VS1 SH-10	F-VS1-10-0100	F-VS1 P-10
F-VS2	F-VS2 SH-02	F-VS2-30-0020	F-VS1 P-02
	F-VS2 SH-03/06	F-VS2-30-0030	F-VS1 P-03/06
	F-VS2 SH-04/12	F-VS2-30-0040	F-VS1 P-04/12
	F-VS2 SH-03/06	F-VS2-30-0060	F-VS1 P-03/06
	F-VS2 SH-04/12	F-VS2-30-0120	F-VS1 P-04/12
	F-VS2 SH-16/20	F-VS2-30-0160	F-VS1 P-16/20

F-VSx P Gauge plates for distribution fuses

F-HSx SHyy

• Size 1:

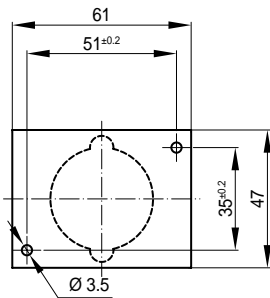

Gauge plates F-VS1 P-03,
F-VS1 P-06 and F-VS1 P-10,
for distribution fuses F-VS1 10-yyyy

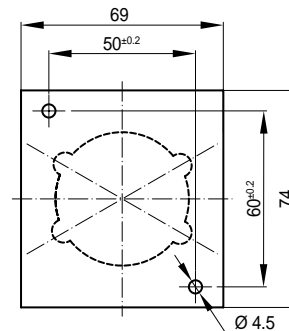

• Size 2:

Gauge plates F-VS2 P-02, F-VS2 P-03/06,
F-VS2 P-04/12 and F-VS2 P-16/20
for distribution fuses F-VS2 30-yyyy

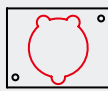
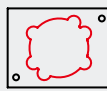
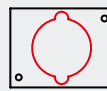
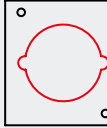
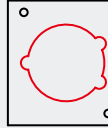
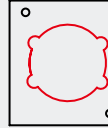

Ordering code:	F-VS1 P-03	F-VS1 P-06	F-VS1 P-10	F-VS2 P-02	F-VS2 P-03/06	F-VS2 P-04/12	F-VS2 P-16/20
Key position							
	Size 1 3 A	Size 1 6 A	Size 1 10 A	Size 2 2 A	Size 2 3 A / 6 A	Size 2 4 A / 12 A	Size 2 16 A / 20 A
Nominal voltage U_{nom}	1,000 V	1,000 V	1,000 V	3,000 V	3,000 V	3,000 V	3,000 V
Nominal current I_{nom}	3 A	6 A	10 A	2 A	3 A and 6 A	4 A and 12 A	16 A and 20 A
Gauge plates for distribution fuses	F-VS1 10-0030	F-VS1 10-0060	F-VS1 10-0100	F-VS2 30-0020	F-VS2 30-0030, F-VS2 30-0060	F-VS2 30-0040, F-VS2 30-0120	F-VS2 30-0160, F-VS2 30-0200

How to choose the proper fuse

The following information is meant to help you select the fuse with the appropriate capacity for the protection of your switchgear:

- In accordance with the standards UIC 550 / EN 50163 a wide range of deviation is permissible for operational voltages. Designed for providing a constant output, inverters, for instance, accept the maximum inrush current when the operational voltage is at its minimum, whereas resistive loads accept the maximum operational current only when the operational voltage has reached its maximum.
That is to say that the selected fuse must be capable of carrying the maximum operational current of your electric equipment without being tripped.
- Fuses are characterised by a fusing conductor wound on a core which has a defined internal resistance so as to ensure that the fusible element will melt in an overcurrent situation and all consumers are cut off when the fuse is blown.

In deciding what capacity the fuse must have, take two things into consideration:

1. The maximum permissible operational voltage of the fuse

During thermal cutout arcs occur between the conductor terminals ($T \approx 15.000^{\circ}\text{C}$), which are to be extinguished by the quenching medium (quartz sand) inside the fuse. The length of time needed for quenching the arc is determined by the distance between the two conductor terminals. If the distance is too narrow the arc will remain for too long, so that the ceramic outer tube of the fuse might explode as a result of the high temperature inside.

2. The internal resistance of the fusible element results in a temperature rise of the fuse with intended use.

Choosing the right size and capacity will prevent the fuse from being exposed to excessive thermal load and aging prematurely. In determining the operational current of the plant and equipment that is to be protected make sure that it equals approx. 70 % of the nominal current of the fuse:

$$I_{nom} = I_{max} / 0.7$$

Example: The maximum operational current is 21 A.
The resulting nominal current of the fuse is:
 $I_{Nom} = I_{max} / 0.7 = 21 \text{ A} / 0.7 = 30 \text{ A}$

So the current-carrying capacity of the conductor must be the same as the nominal current of the fuse. For trip currents and temperatures refer to the time/current characteristics on page 3 and 5.



Schaltbau GmbH has an environment management system that has been certified since 1994.

Schaltbau GmbH has a quality management system that has been certified since 1994.

Electrical Components and Systems for Railway Engineering and Industrial Applications

Connectors

- Connectors manufactured to industry standards
- Connectors to suit the special requirements of communications engineering (MIL connectors)
- Charging connectors for battery-powered machines and systems
- Connectors for railway engineering, including UIC connectors
- Special connectors to suit customer requirements

Snap-action switches

- Snap-action switches with positive opening operation
- Snap-action switches with self-cleaning contacts
- Enabling switches
- Special switches to suit customer requirements

Contactors

- Single and multi-pole DC contactors
- High-voltage AC/DC contactors
- Contactors for battery powered vehicles and power supplies
- Contactors for railway applications
- Terminal bolts and fuse holders
- DC emergency stop switches
- Special contactors to suit customer requirements

Control devices

- Master controllers and reversers for railway applications
- Toggle switch devices
- Handles and foot switches for railway applications (dead-man equipment)
- Switching elements with high breaking capacity
- Emergency brake handles
- Signal devices

Transportation system equipment

- Power supplies for passenger coaches (electric equipment)
- Battery chargers for locomotives and passenger coaches
- High-voltage equipment for single and multi-phase operation
- Heating devices and heating controls
- Design and engineering services for high-voltage equipment
- Special equipment to suit customer requirements

Schaltbau GmbH

Hollerithstrasse 5
81829 Munich
Germany

Phone +49 89 9 30 05-0
Fax +49 89 9 30 05-350
e-Mail contact@schaltbau.de
Internet www.schaltbau.de

with compliments: