

4

Electrics for rolling stock

Series ZH1500

**Disconnecting and
Earthing Device**

**Installation and
maintenance instructions**

Manual F186.en



Document Revision History:

Document no.	Date	Version	Change	Pages
	Dec. 01, 2015	V 1.0	First issue (translation from german)	all

Contents

1. Important Basic Information	3
1.1 Legal Notes	3
1.2 Other Applicable Documents	3
1.3 Conventions for this Installation and Maintenance Instructions	3
2. General and Security Information	4
2.1 Observing the Installation and Maintenance Instructions	4
2.2 User Obligations	4
2.3 Proper Use	5
2.4 Ambient Conditions	5
3. Dangers and Security Measures	6
3.1 Electrical Dangers	6
3.2 Mechanical Dangers	6
3.3 Lubricants	7
4. Description	8
5. Installation	9
5.1 Safety	9
5.2 Installation Regulations	9
5.3 Preparing Measures	10
5.4 Handling the Installed Disconnecting and Earthing Device	11
5.5 Dimensions	12
5.6 Laying and Connecting the High Voltage Cable	12
5.7 Laying and Connecting the Earthing Cable	14
5.8 Mounting the Device into the Switch Gear Cabinet	14
5.9 Perform Functional Check	16
5.10 Readjust the Device	17
5.11 Perform Final Works	18
6. Maintenance	19
6.1 Safety	19
6.2 Maintenance Intervals	20
6.3 Main Contacts ZS, WA and Main Contact Bridge	20
6.4 Contacts K1/13, K1/14 and Contact Bridge K1	23
6.5 Drive Unit	25
6.6 Detent Mechanism	26
6.7 Insulation Foil	26
6.8 Arc Chamber	27
7. List of spare parts	28
8. Technical Data	29

1. Important Basic Information

1.1 Legal Notes

Without prior written consent of Schaltbau GmbH, the installation and maintenance instructions are not allowed to be electronically or mechanically reproduced – as a whole or in parts – be distributed, changed, transmitted, translated into another language or used in any other way.

Schaltbau GmbH cannot be held liable for damage caused by not observing (or only partly observing) the installation and maintenance instructions.

1.2 Other Applicable Documents

Technical documentation of purchased parts, data sheets of parts or check lists and protocols, as for example of completed maintenance work are regarded as other applicable documents.

1.3 Conventions for this Installation and Maintenance Instructions

This instructions describe the installation and maintenance of the disconnecting and earthing device.

Cross references are presented in ***bold italics***.

To highlight particularly important safety instructions and other information, the following symbols are used in this document:

DANGER

Indicates a hazardous situation with a high level of risk which, if not avoided, will result in death or serious injury.

WARNING

Indicates a hazardous situation with a medium level of risk which, if not avoided, could result in death or serious injury.

CAUTION

Indicates a hazardous situation with a low level of risk which, if not avoided, may result in minor or moderate injury.

NOTICE

Indicates a hazardous situation which, if not avoided, may result in property damage, such as service interruption or damage to equipment or other materials.



Refers to technical features and methods aimed at facilitating work or to particularly important information.

2. General and Security Information

The electrical device described here is a part of constructions for the use in rail vehicles. It has been designed and checked in accordance with approved engineering regulations. Electrical appliances can generally cause severe harm to one's health and also material damage if used or operated improperly, or if not maintained sufficiently. This instruction for the installation and maintenance of the device must therefore be strictly adhered to.

Any uncertainties must be clarified and all queries must include details of the type of device and the serial number.

The planning and carrying out of mechanical and electrical installations, transportations, assemblies and commissioning as well as maintenance and repair work, must only be carried out by responsible experts with the appropriate expertise.

This is not only important when observing the general construction regulations and safety instructions on work with high voltage systems (e.g. DIN, VDE), but also regarding the professional use of approved tools and if required, the use of personal protective equipment. Electrical devices are to be protected, as much as possible, from dust and moisture during installation, operation or storage.

If there is any doubt, it is recommended to make use of the support and service of the SCHALTBAU GmbH for mounting, putting into operation and for incoming service tasks.

2.1 Observing the Installation and Maintenance Instructions

- ▶ All staff must read and understand the instructions and adhere to them when working with the device.
- ▶ **Always carefully observe all safety warnings!**

2.2 User Obligations

- ▶ Observe all applicable national regulations, all safety, injury and environmental precautions as well as the recognised technical regulations with regards to safe and professional work.
- ▶ The proper functioning of all available protection and safety devices is to be checked regularly.
- ▶ Work on electrical devices must only be carried out by experts or by instructed persons under the guidance and supervision of an expert according to the electro-technical regulations.
- ▶ An expert is a person who can judge and recognise the possible dangers of the jobs commended to him based on his training, knowledge and experience and by knowledge of the appropriate regulations.
- ▶ Staff must be informed clearly about who is responsible for the maintenance of the disconnecting and earthing device.
- ▶ Staff in training, personnel being introduced to the device, or staff in any type of general apprenticeship, must only maintain the disconnecting and earthing device while under permanent supervision of an experienced person.

2.3 Proper Use

The disconnecting and earthing device must only be used:

- ▶ If all safety devices are present, properly installed and fully operative.
- ▶ If within the limits of maintenance works only SCHALTBAU original spare parts are used.

- ▶ Maintenance work not mentioned in this installation and maintenance instructions must only be carried out by Schaltbau GmbH service staff.
- ▶ The disconnecting and earthing device must not be converted or otherwise modified without prior written consent of Schaltbau GmbH. Violations against this will result in the exclusion of liability on the part of the manufacturer.
- ▶ The disconnecting and earthing device may in the normal operation on principle only be operated if all protective devices are present, have been installed properly and are fully functional.
- ▶ In operating modes in which the protective devices must be removed or stopped, the disconnecting and earthing device must generally only be used by Schaltbau GmbH service staff. When maintenance works are being carried out, this has to be clearly indicated on the disconnecting and earthing device, for example with a sign reading “WARNING – maintenance work. Do not touch!”. Otherwise, third-party access to the disconnecting and earthing device must be prevented for. Once the work has been carried out, all protective devices must be properly installed again and checked for proper functionality.
- ▶ All faults displayed by the system or any other determined faults or damage must immediately be reported and attended to, see “**3.1 Electrical Dangers**” on **page 6**.
- ▶ None of the operating conditions mentioned in chapter “**8. Technical Data**” on **page 29** such as voltage, currents, ambient conditions etc. must be changed.
- ▶ Work on the disconnecting and earthing device must only be carried out by staff who meets the requirements set out in these installation and maintenance instructions.
- ▶ The bridging of switches or other control devices is prohibited.

2.4 Ambient Conditions

NOTICE

The disconnecting and earthing device has been designed for use in specific ambient conditions.

- ▶ The disconnecting and earthing device must only be operated in accordance with the ambient conditions as mentioned in chapter “**8. Technical Data**” on **page 29**.

3. Dangers and Security Measures



3.1 Electrical Dangers

	⚠ DANGER
	<p>The disconnecting and earthing device contains components that may carry high voltage. Deadly hazard! Always consider the following safety rules before carrying out work on the disconnecting and earthing device:</p> <ul style="list-style-type: none"> ▶ Disconnect ▶ Ensure that it is not possible to reconnect unintentionally ▶ Make sure that there is no voltage present ▶ Earth and short circuit the installation ▶ Clearly mark your work area ▶ Besides the main electric circuit, also earth and short circuit additional and auxiliary circuits ▶ Insulate or cover adjacent energized parts ▶ For passenger coaches or other rail vehicles disconnect the train bus bar ZS

3.2 Mechanical Dangers

	⚠ CAUTION
	<p>The disconnecting and earthing device contains components that are subject to mechanical stress. There is a risk of crushing!</p> <ul style="list-style-type: none"> ▶ Use only appropriate tools for maintenance work on the disconnecting and earthing device. ▶ Ensure that components, which are subject to mechanical stress, are secured before installing or dismantling these components.

	⚠ CAUTION
	<p>When working on the disconnecting and earthing device there is a risk of injuries!</p> <ul style="list-style-type: none"> ▶ Use appropriate tools for works on the disconnecting and earthing device. ▶ Wear closely fitting work clothes so that pieces of clothing cannot be jammed into or get entangled in parts of the machine.

  	⚠ CAUTION
<p>In order to avoid possible injuries when working on the disconnecting and earthing device, the following protective equipment is required:</p> <ul style="list-style-type: none"> ▶ Wear protective gloves in order to avoid injuries to the hands. ▶ Wear protective shoes in order to avoid injuries through falling down parts. ▶ Wear protective glasses with hardened glass in order to avoid injuries to the eyes. 	

3.3 Lubricants

	⚠ WARNING
<p>Mixing lubricants with other lubricants can cause explosive fumes. Risk of explosion!</p> <ul style="list-style-type: none"> ▶ Don't mix lubricants with other lubricants. ▶ Observe the manufacturer's instructions. 	

	⚠ WARNING
<p>Lubricants may pose a risk to the health.</p> <ul style="list-style-type: none"> ▶ Observe the manufacturer's instructions. ▶ Don't eat, drink or smoke while handling lubricants. ▶ Wash hands thoroughly with soap and water after handling lubricants. 	

NOTICE
<p>Lubricants can be harmful to the environment.</p> <ul style="list-style-type: none"> ▶ Ensure that lubricants don't enter any sewerage system or body of water or seep into the ground. ▶ Dispose of lubricants according to the locally applicable national regulations.

4. Description

The disconnecting and earthing device ZH 1500 is a device for disconnecting and earthing a high voltage installation from the supplying bus bar. When used in high voltage switch gear cabinets, the switching function is triggered forcibly when opening the lid or the door respectively of the switch gear cabinet. The device serves as a guarantee of safety when working on disconnected and earthed high voltage installations and is essentially made up of the following parts:

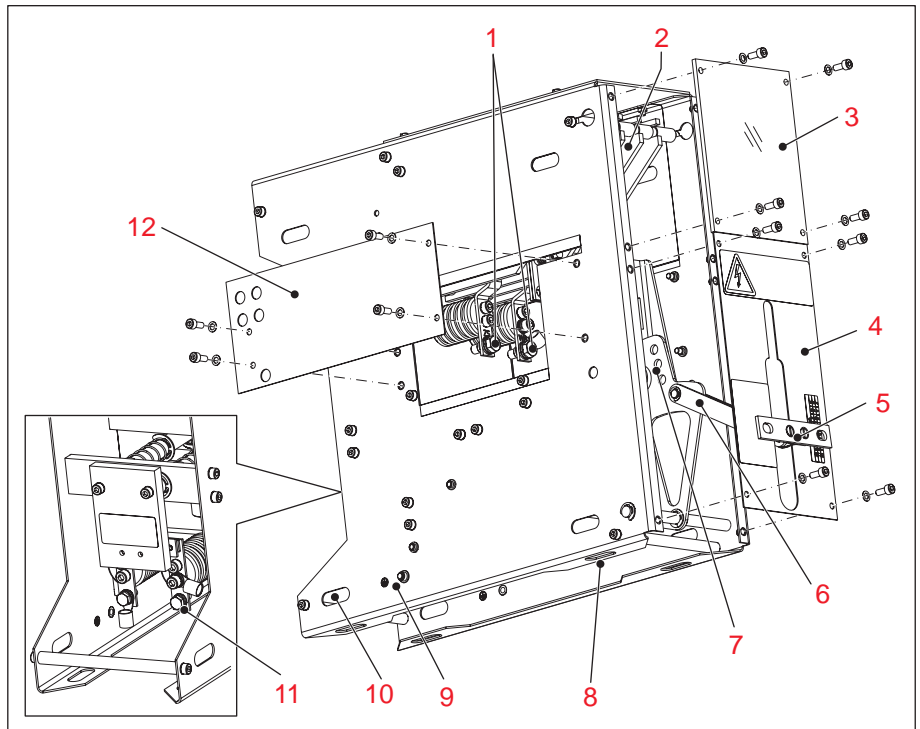



Figure 1

Pos.	Description
1	Main contacts (termination M8): - ZS (train bus bar) - WA (connection to coach)
2	Arc chamber
3	Inspection window
4	Front panel
5	Lid or door connection respectively
6	Lever
7	Interlock drill holes for padlocks for protection against unintended connection in disconnected position
8	Elongated holes for vertical mounting on the bottom
9	Earthing terminal for housing (on inner side of housing)
10	Elongated holes for mounting on left or right lateral wall
11	Earthing contact WA (contact M6)
12	Lateral mounting cover for contacts ZS and WA

5. Installation

5.1 Safety

	⚠ DANGER
	<p>The disconnecting and earthing device contains components that may carry high voltage. Deadly hazard! Always consider the following safety rules before carrying out work on the disconnecting and earthing device:</p> <ul style="list-style-type: none">▶ Disconnect▶ Ensure that it is not possible to reconnect unintentionally▶ Make sure that there is no voltage present▶ Earth and short circuit the installation▶ Clearly mark your work area▶ Besides the main electric circuit, also earth and short circuit additional and auxiliary circuits▶ Insulate or cover adjacent energized parts▶ For passenger coaches or other rail vehicles disconnect the train bus bar ZS

5.2 Installation Regulations

The disconnecting and earthing device must be installed into switch gear cabinets in such a way that one cannot reach for the open contacts at the rear or on the bottom of the device!

5.3 Preparing Measures

For the installation of the disconnecting and earthing device into switch gear cabinets, adequate fixing drill holes have to be provided. The installation may be made to the left or right lateral wall or vertically on the bottom of the switch gear cabinet. For measures of the installation refer to the section **“5.5 Dimensions”, page 12.**

For fixing the device you need 4 hexagon head bolts M10 and – depending on the installation situation – nuts as well as adequate washers / screw locking elements.

Fixing drill holes have also to be provided for connecting the lever to the lid or door respectively of the switch gear cabinet.

For connecting the cables at the main contacts ZS and WA, the lateral mounting covers have to be removed. When necessary for the installation, the inspection window and the front panel can be removed as well.

The connecting cables ZS and WA have to be connected with angle cable lugs or straight standard cable lugs. When straight standard cable lugs are used, they have to be insulated on the cable with an appropriate shrink sleeving with 20 mm of overlap!

The device should be wired when dismantled because of better access.

When the operating lever is installed to the lid/door, the maximum permissible opening angle is 90°. When the opening angle is wider, the operating lever may warp or twist and the device won't switch anymore after a certain amount of time.

Therefore a catching device (rope, chain, hinge, etc.) has to be provided preventing the lid/door to be opened by an angle of more than 90°.

5.4 Handling the Installed Disconnecting and Earthing Device

If the lid/door of the switch gear cabinet has to be opened by an angle of more than 90° when the device is installed (e.g. for maintenance/installation works), the operating lever must be removed from the lid or door, see **Figure 2**.

Failing this, the operating lever may warp or twist (because of the lid's own weight or because somebody unintentionally leans against it) and the device won't switch anymore after a certain amount of time.

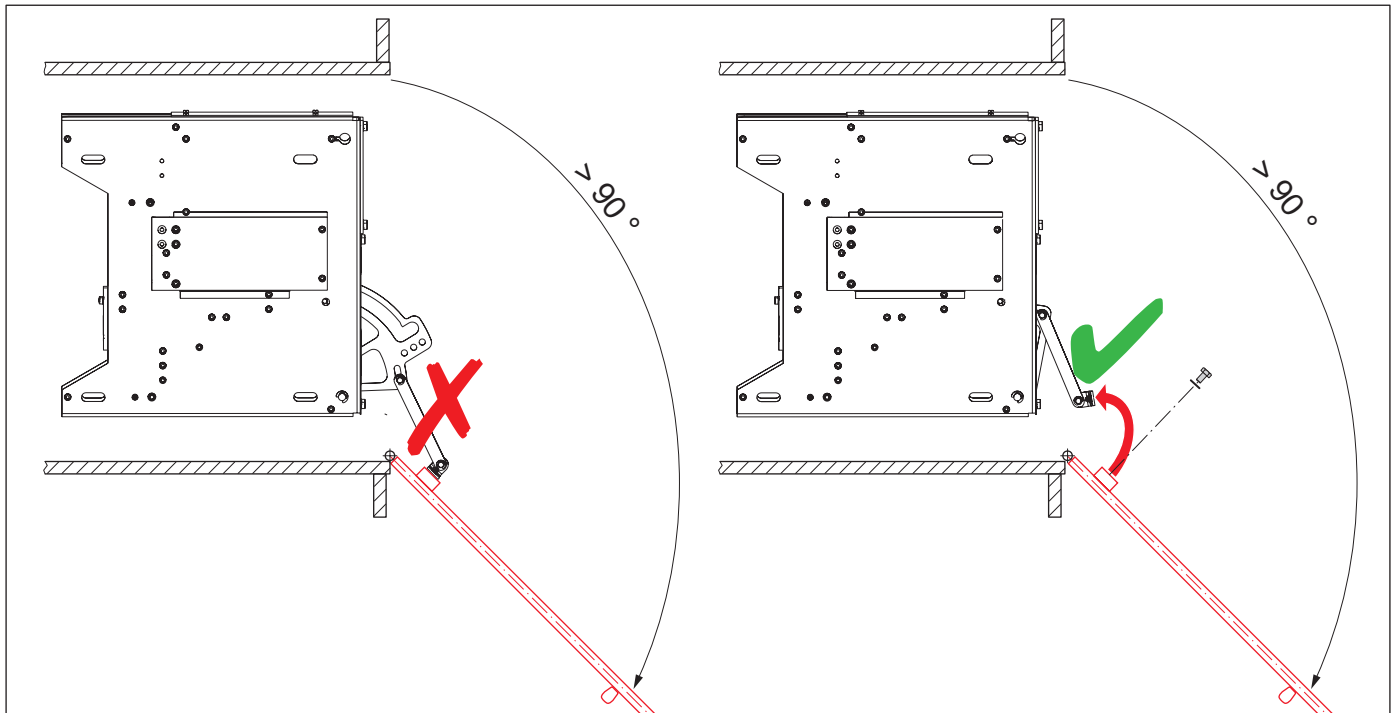

Figure 2: When opening the lid/door by more than 90°, the operating lever must be removed.

5.5 Dimensions

For dimensions of the device and the necessary measures for mounting refer to the following illustration.

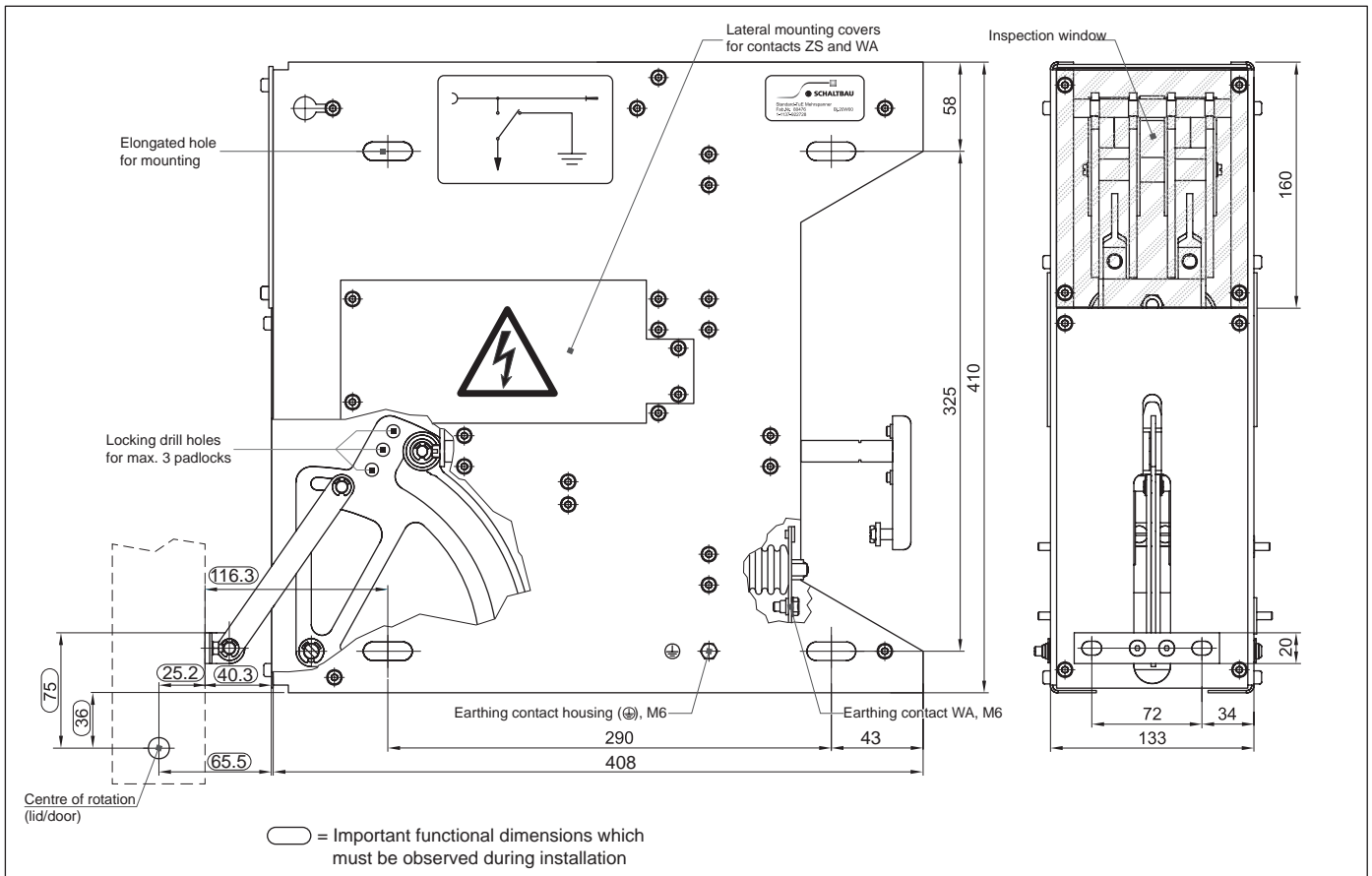

Figure 3: Dimensions (measurements in mm)

5.6 Laying and Connecting the High Voltage Cable

The device should be wired when dismantled because of better access.

NOTICE

Damages when laying the cables may damage the device or lead to malfunctions.

- ▶ Make sure that the insulation foils on the inner sides of the lateral walls are not damaged and that the contacts are not twisted when threading the cables.

1. Dismount the lateral mounting cover and – if necessary – the inspection window and the front panel.
2. Thread the cable ZS (1) on the right lateral wall (seen from behind) from the backside underneath the cross bolt (2) into the device, see **Figure 4**.

3. After that, lay the cable ZS (1) across the front bearing bridge (3) to the ZS contact (4), see **Figure 4**.
4. Connect the cable lug (5) of the ZS cable with the hexagon head bolt M8 (6) and detent-edged ring (7) to the ZS contact, see **Figure 4**.
5. Secure the cable ZS with cable ties on the following positions as indicated in **Figure 4**:
 - on the two lateral fastening elements (8+9),
 - on the bearing bridge (3),
 - and on the back cross bolt (2).
6. Thread the cable WA in the same way on the left lateral wall (seen from behind) from the backside underneath the cross bolt into the device and lay it across the front bearing bridge to the WA contact.
7. Connect the cable lug of the WA cable with the hexagon head bolt M8 and detent-edged ring to the WA contact.
8. Secure the cable WA with cable ties on the two lateral fastening elements, on the bearing bridge and on the back cross bolt.
9. Mount the lateral mounting covers and, if necessary, the inspection window and the front panel.

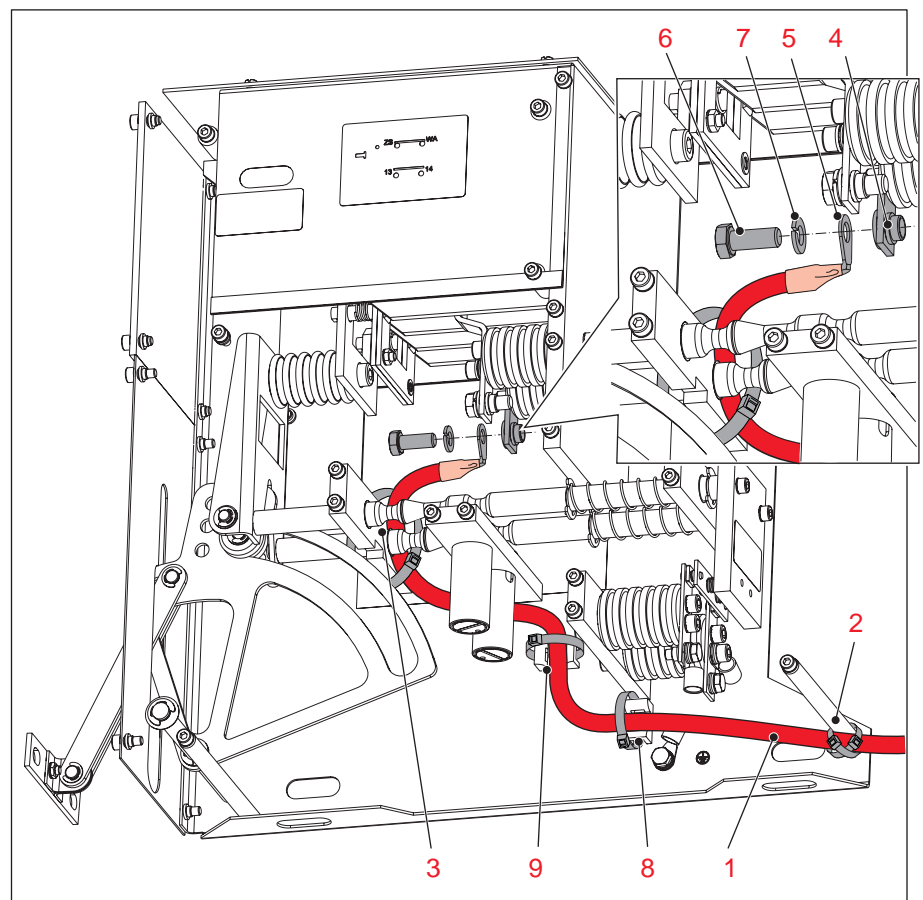

Figure 4: Laying and connecting the high voltage cables

5.7 Laying and Connecting the Earthing Cable

1. Thread the earthing cable (1) from the backside underneath the cross bolt (6) into the device, see **Figure 5**.
2. After that, lay the earthing cable (1) to the earthing contact (2), see **Figure 5**.
3. Connect the cable lug (3) of the earthing cable with the hexagon head bolt M6 (4) and detent-edged ring (5) to the earthing contact (2), see **Figure 5**.
4. Secure the earthing cable with cable ties on the back cross bolt (6), see **Figure 5**.

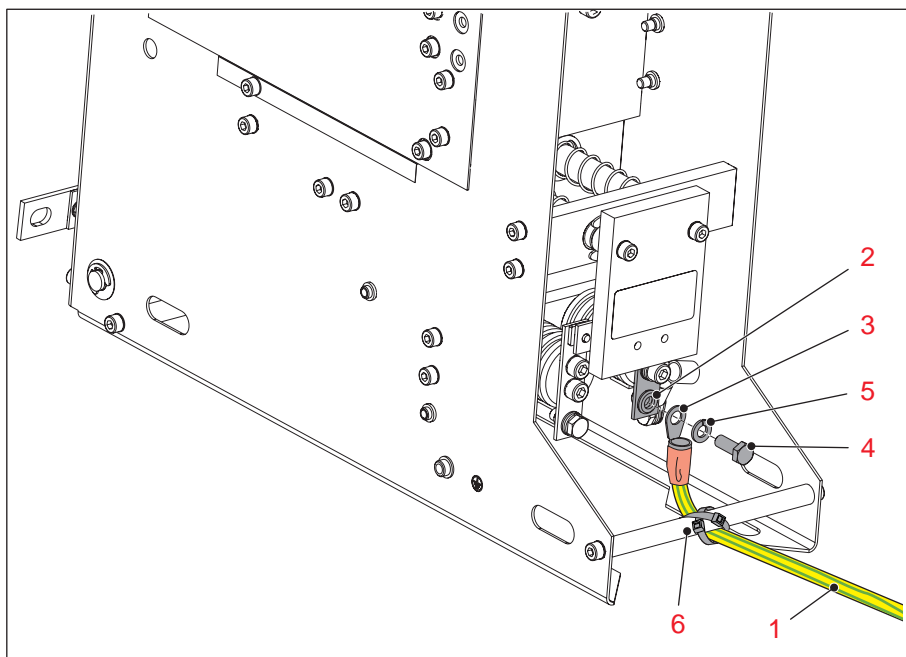

Figure 5: Laying and connecting the earthing cable

5.8 Mounting the Device into the Switch Gear Cabinet

After the device has been wired, it may be mounted to its intended place in the switch gear cabinet.

1. Screw on the device at the 4 elongated holes with hexagon head bolts M10 at the prepared fastening drill holes in such a way that the following functional dimensions are coercively maintained, see **Figure 6**:
 - 65.5 mm between front panel of the device and centre of rotation of the lid/door of the switch gear cabinet (1).
 - 36 mm between bottom side of the device and centre of rotation of the lid/door of the switch gear cabinet (2).
 - 25.2 mm between lid/door connection (4) of the device and centre of rotation of the lid/door of the switch gear cabinet (3).
2. After the functional dimensions have been adjusted correctly, set tight the 4 bolts M10.

3. Make the lid/door connection (4) of the device with the lid/door of the switch gear cabinet, see **Figure 6**.
4. Perform a functional check and readjust, if necessary. Refer to section **“5.9 Perform Functional Check”, page 16** and section **“5.10 Readjust the Device”, page 17**.
5. After a successful functional check, the locking caps contained in the accessories kit have to be coated with glue and fixed onto the hexagon head bolts M10 for insulation, refer to section **“5.11 Perform Final Works”, page 18**.

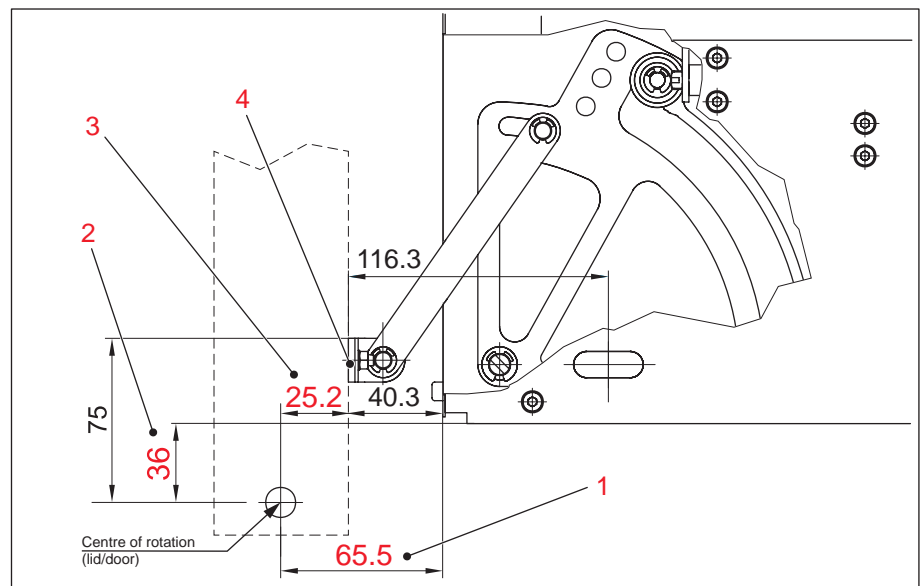

Figure 6: Functional dimensions which have to be maintained coercively (measurements in mm)

5.9 Perform Functional Check

After the device has been fixed and the connection to the lid or door has been made, a functional check has to be performed before the initial operation. In doing so, the switching performance of the contacts has to be observed. This can be made either through the inspection window or by taking off the lateral mounting cover.

NOTICE

When the operating lever is installed to the lid/door, the maximum permissible opening angle is 90°. When the opening angle is wider, the operating lever may warp or twist and the device won't switch anymore after a certain amount of time.

▶ Do not open the lid/door by an angle of more than 90°

1. Slowly open the lid or the door respectively of the switch gear cabinet until an opening angle of approx. 25° has been reached (1):
 - The main contacts ZS (3) and WA (4) must still be closed and the contact spring must be pre-stressed (see **Figure 7** and **Figure 8**).
2. Then slowly open further the lid or the door respectively (> 25°):
 - You must feel a resistance.
 - After the resistance has been overcome, the switching mechanism must trigger and the main contact bridge (5) leap to the front (see **Figure 8**).
 - The main contacts ZS (3) and WA (4) are now open, the earthing contact has not yet been closed (**Figure 8**).
3. After that, slowly open the lid or the door respectively further, until an opening angle of approx. 60° has been reached (2) (**Figure 7**).
 - At an opening angle of approx. 60°, the earthing contact must trigger and the contact must be closed.

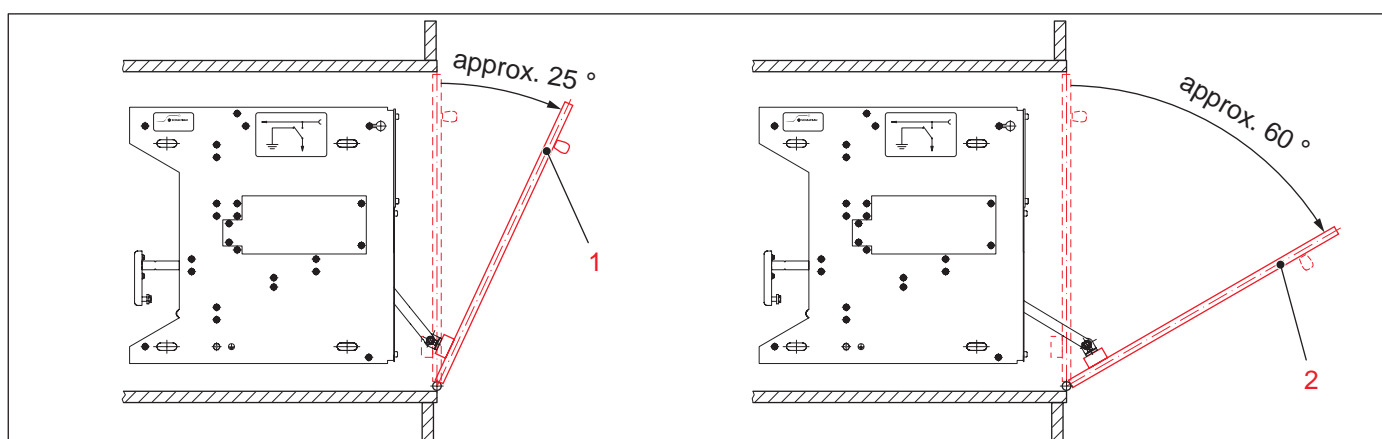

Figure 7: 25° and 60° opening angle of the lid of the switch gear cabinet for functional check

If the switching mechanism triggers as described in the previous steps 1 to 3, the device is working properly.

If the main contacts ZS (3) and WA (4) are open already at an opening angle of the lid / the door of less than 25°, the device must be readjusted. Refer to section **“5.10 Readjust the Device”, page 17**.

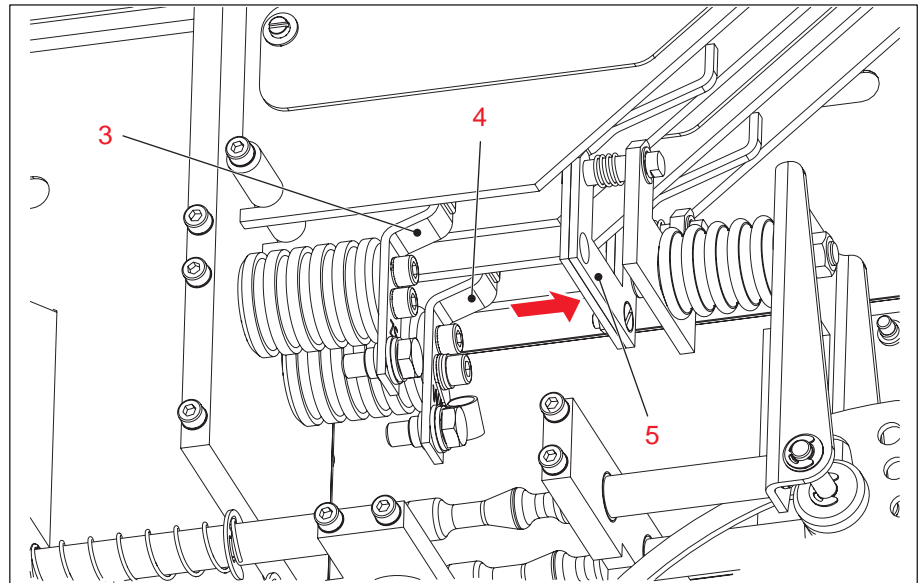

Figure 8: Disconnecting of the main contacts at an opening angle of the lid of approx. 25°

5.10 Readjust the Device

1. For readjusting, slightly release the 4 fixing bolts M10 (6) of the device and push the device forward, in the direction of the lid or door respectively, see **Figure 9**.
2. Retighten the 4 fixing bolts M10 (6).
3. Perform a functional check again, according to section “5.9 Perform Functional Check”, see page 16.
4. If necessary, repeat readjusting until the switching mechanism of the device is working properly, as described in “5.9 Perform Functional Check” on page 16.

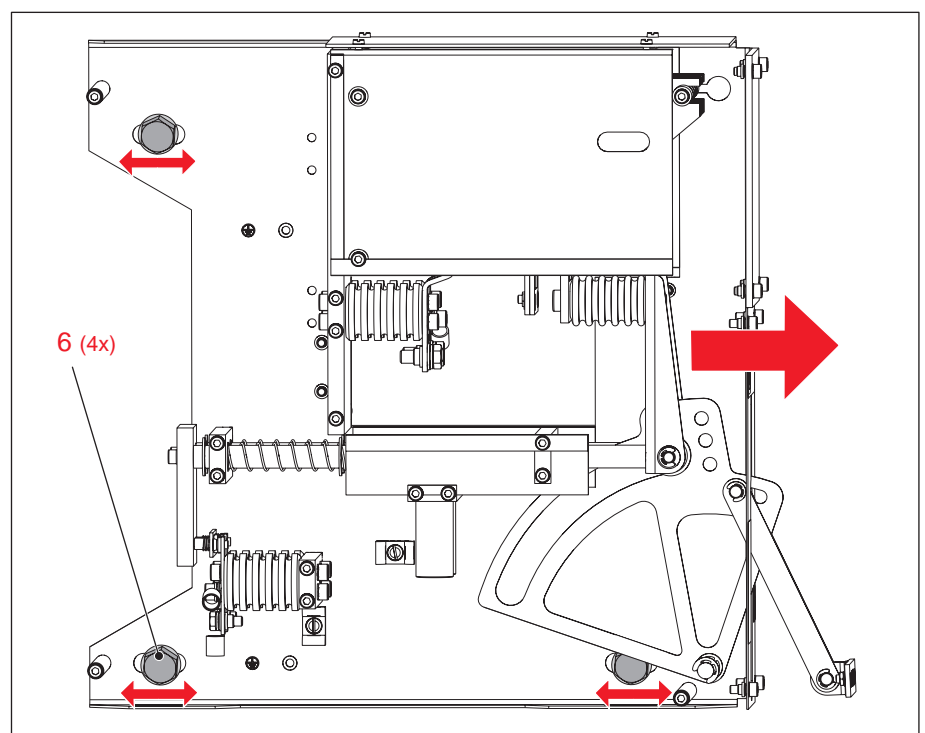

Figure 9: Readjusting the device

5.11 Perform Final Works

NOTICE

For insulation, locking caps must be fixed on the bolt heads of the 4 fixing bolts.

1. Put glue on the inner side of the 4 locking caps (1) contained in the accessories kit and fix the locking caps on the screw heads (2) of the 4 fixing bolts, see **Figure 10** and **Figure 11**.
2. If necessary, mount the inspection window and the lateral mounting cover.
3. Perform a final functional check, refer to section **“5.9 Perform Functional Check”** on **page 16**.

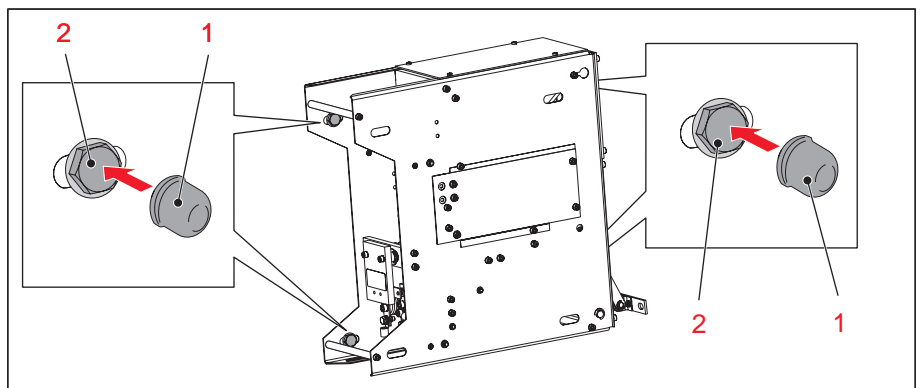

Figure 10: Fixing locking caps (when mounting on a lateral wall)

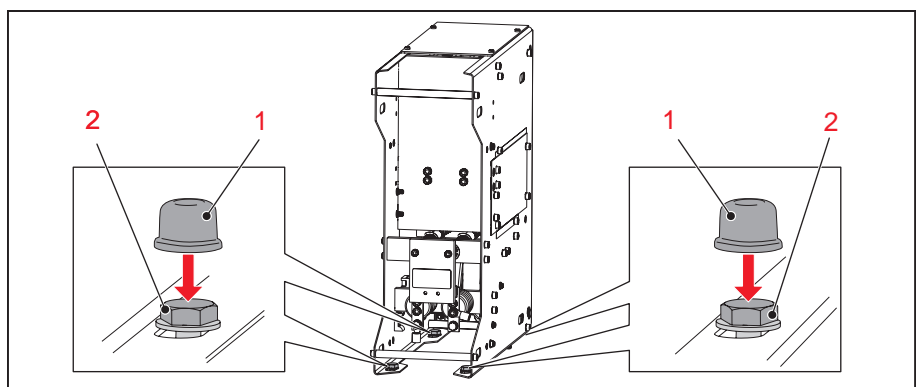





Figure 11: Fixing locking caps (when mounting vertically on the bottom)

6. Maintenance

6.1 Safety

Before starting work on the disconnecting and earthing device, the following safety regulations have to be read and understood.

	<p>⚠ DANGER</p> <p>The disconnecting and earthing device contains components that may carry high voltage. Deadly hazard! Always consider the following safety rules before carrying out work on the disconnecting and earthing device:</p> <ul style="list-style-type: none"> ▶ Disconnect ▶ Ensure that it is not possible to reconnect unintentionally ▶ Make sure that there is no voltage present ▶ Earth and short circuit the installation ▶ Clearly mark your work area ▶ Besides the main electric circuit, also earth and short circuit additional and auxiliary circuits ▶ Insulate or cover adjacent energized parts ▶ For passenger coaches or other rail vehicles disconnect the train bus bar ZS
	<p>⚠ CAUTION</p> <p>The disconnecting and earthing device contains components that are subject to mechanical stress. There is a risk of crushing!</p> <ul style="list-style-type: none"> ▶ Use only appropriate tools for maintenance work on the disconnecting and earthing device. ▶ Ensure that components, which are subject to mechanical stress, are secured before installing or dismantling these components.
	<p>⚠ CAUTION</p> <p>When working on the disconnecting and earthing device there is a risk of injuries!</p> <ul style="list-style-type: none"> ▶ Use appropriate tools for works on the disconnecting and earthing device. ▶ Wear closely fitting work clothes so that pieces of clothing cannot be jammed into or get entangled in parts of the machine.
	<p>⚠ CAUTION</p> <p>In order to avoid possible injuries when working on the disconnecting and earthing device, the following protective equipment is required:</p> <ul style="list-style-type: none"> ▶ Wear protective gloves in order to avoid injuries to the hands. ▶ Wear protective shoes in order to avoid injuries through falling down parts. ▶ Wear protective glasses with hardened glass in order to avoid injuries to the eyes.

6.2 Maintenance Intervals

The disconnecting and earthing device is low-maintenance. However, the condition of the device also depends on the ambient conditions. In order to guarantee a prolonged operational life span of the disconnecting and earthing device, the following maintenance measures have to be performed regularly.

Maintenance measure	Interval
Cleaning of the device and replacement of persistently soiled or damaged parts	▶ In case of heavy soiling
Check of the complete device and replacement of damaged parts	▶ After a shutt-off under load
Replace wear and tear parts completely	▶ After approx. 1000 switching cycles, however, after 30 years of use at the latest (end of useful life)

6.3 Main Contacts ZS, WA and Main Contact Bridge

Check main contacts ZS, WA and main contact bridge

Required tools

- ▶ Allen wrench size 4

Procedure

1. Make sure that the system is electrically disconnected and that all the safety regulations have been fulfilled (refer to section “**6.1 Safety**” on **page 19**).
2. Disassemble the inspection window and the lateral mounting cover.
3. Check silver contact surfaces on the main contacts ZS (1) and WA (2) as well as on the main contact bridge (3), see **Figure 12** and **Figure 13**:
 - In spite of distinct burn-off traces (black soot) the contacts must show a surface curved to the outside.
 - In the case of burned off contacts replace the complete main contacts ZS (1) and WA (2) and the main contact bridge (3), refer to section “**Replace main contacts ZS and WA**” on **page 21** and “**Replace main contact bridge and pressure springs**” on **page 22**.
4. Check spring mechanism (4) of the main contact bridge (3) for ease of movement, see **Figure 13**.
 - When the main contact bridge (3) sticks, clean the bearing spots (5) and the axles (6).
5. Check pressure springs (4) for spring break and fatigue.
 - Replace damaged parts, refer to section “**Replace main contacts ZS and WA**” and “**Replace main contact bridge and pressure springs**” on **page 21** and **page 22**.

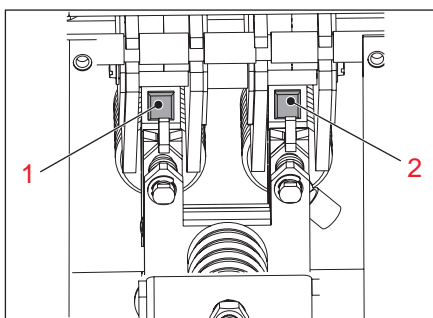

Figure 12

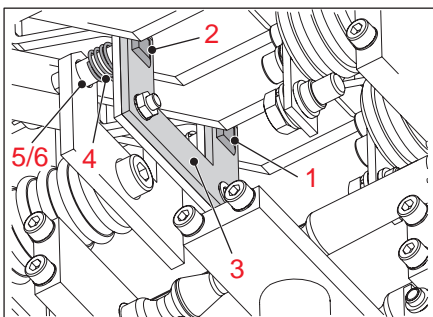

Figure 13

Replace main contacts ZS and WA

Required tools

- ▶ Allen wrench size 4
- ▶ Open-end wrench size 13

Procedure

1. Make sure that the system is electrically disconnected and that all the safety regulations have been fulfilled (refer to section “6.1 Safety”, page 19).
2. Remove the disconnecting and earthing device from the switch gear cabinet.
3. Disassemble the inspection window and the two lateral mounting covers.
4. Push the moveable drive unit (7) 4. with the main contact bridge against the detent force to the front, see **Figure 14**.
5. Release hexagon head bolts M8 of the coach-side cable contacts on the main contacts ZS (1) and WA (2) and slide off bolts, serrated lock rings and cable (**Figure 14**).

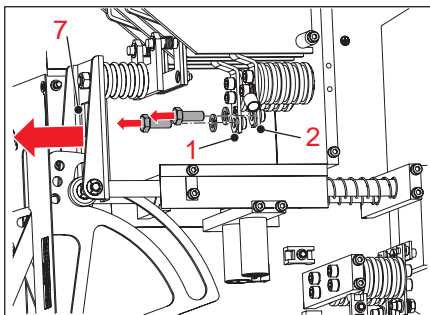

Figure 14

NOTICE

Dropped serrated lock rings or retaining washers remaining in the device may cause failures and damages to the device.

- ▶ Look for dropping serrated lock rings and retaining washers and remove them immediately.

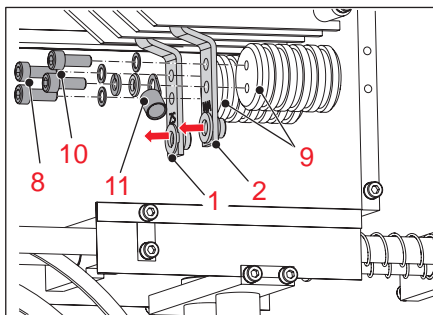

Figure 15

6. Release the two screws M6 (8) of the main contact ZS (1) and slide off screws, retaining washers as well as the main contact ZS (1) from the isolator (9), see **Figure 15**.
7. Release the two screws M6 (10) of the main contact WA (2) and slide off screws, retaining washers, serrated lock ring, cable lug (11) with cable (to contact K1/14) as well as the main contact WA (2), see **Figure 15**.
8. Screw new main contacts ZS (1) and WA (2) with the screws M6 (8/10) and the retaining washers on the isolators (9) (**Figure 15**). In doing so, observe the following:
 - Fix main contact ZS (1) to the left isolator.
 - Fix main contact WA (2) together with the cable lug (11) (cable to contact K1/14) and serrated lock ring to the right isolator. (Each seen from the front through the inspection window.)
 - Arrange the main contacts in such a way that the silver contact surfaces overlap with those of the main contact bridge in the closed condition.
9. Set tight the screws M6 (8/10) of the two main contacts, see **Figure 15**.
10. Connect the coach-side cables to the main contacts ZS (1) and WA (2) with the hexagon head bolts M 8 and serrated lock rings, see **Figure 14**.

Replace main contact bridge and pressure springs

Required tools/Auxiliary equipment

- ▶ Allen wrench size 4
- ▶ Open-end wrench size 8 and 13
- ▶ Slotted screwdriver size 5
- ▶ Screw lock lacquer

Procedure

1. Make sure that the system is electrically disconnected and that all the safety regulations have been fulfilled (refer to section “**6.1 Safety**”, page 19).

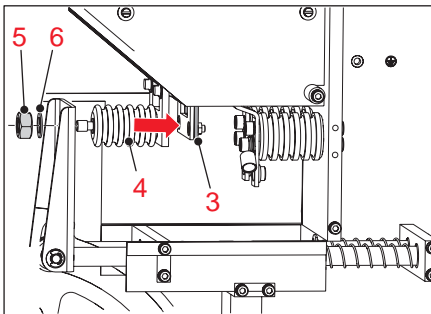

Figure 16

2. Remove the disconnecting and earthing device from the switch gear cabinet.
3. Disassemble the inspection window and the two lateral mounting covers.

For better accessibility, the main contact bridge (3) is removed together with the isolator (4) as a complete unit, see **Figure 16**.

4. Release nut M8 (5) on the cross bearer drive unit and slide off together with retaining washer (6).

5. Remove the entire unit.

6. Pull off the circlips (7) laterally from the contact shafts (8), see **Figure 17**.

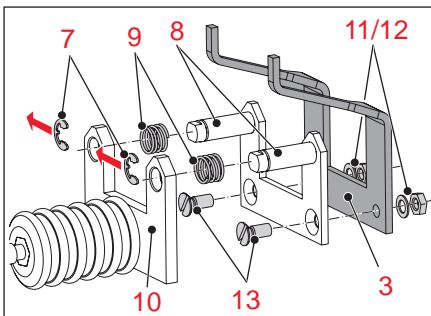

Figure 17

7. Pull contact shafts (8) with pressure springs (9) and intermediate sheet out of the bearing support (10). Remove the pressure springs (9) from the contact shafts (8).

8. Release the 2 nuts M5 (11) and remove them together with the retaining washers (12).

9. Slide off the 2 counter-sunk screws M5 (13) from the intermediate sheet and remove the main contact bridge (3).

10. Screw a new main contact bridge (3) onto the intermediate sheet, using the 2 counter-sunk screws (13), retaining washers (12) and nuts M5 (11).

11. Push new pressure springs (9) onto the contact shafts (8).

12. Insert the contact shafts (8) with pressure springs (9) and intermediate sheet into the bearing support (10).

13. Push the circlips (7) laterally onto the contact shafts (8).

14. Attach the complete unit to cross bearer drive unit and tighten it with the nut M8 (5), see **Figure 16**.

15. Apply screw lock lacquer to the nut M8 (5) as well as to the bolt thread.

6.4 Contacts K1/13, K1/14 and Contact Bridge K1

Check contacts K1/13, K1/14 and contact bridge K1

Required tools/Auxiliary equipment

- ▶ Continuity tester

Procedure

1. Make sure that the system is electrically disconnected and that all the safety regulations have been fulfilled (refer to section “6.1 Safety”, page 19).
2. Disassemble the inspection window and the lateral mounting cover.
3. At the rear of the device use the continuity tester and check the continuity of the earthing cable between the right contact K1/13 (1) and the earthing clamp (2) at the housing, see **Figure 18**.
4. Use the continuity tester and check the continuity between main contact WA (3) and the left contact K1/14 (4) at the back of the device, see **Figure 19**.

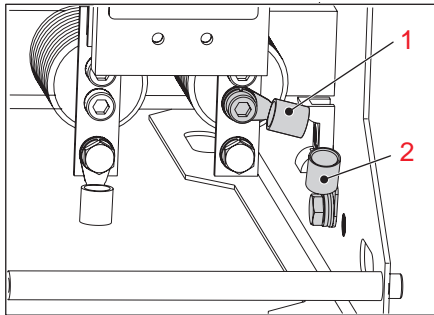

Figure 18

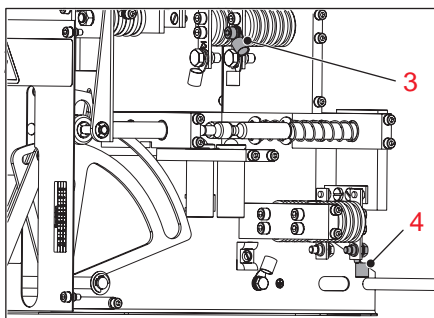

Figure 19

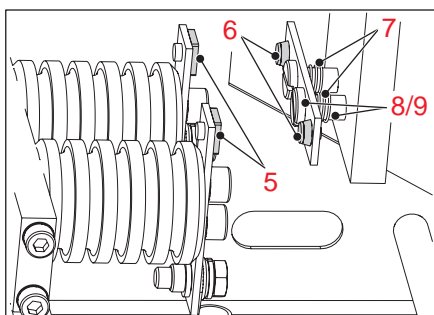

Figure 20

When the continuity exists, the contact bridge K1 and the contacts K1/13 and K1/14 are okay.

If there is no continuity, the following parts must be checked:

- The silver contact surfaces on the contacts K1/13 and K1/14 (5) as well as on the contact bridge K1 (6), see **Figure 20**.
 - In spite of distinct burn-off traces (black soot) the contacts must show a plane surface.
 - In the case of burned-off contacts replace the complete contacts K1/13 and K1/14 (5) and the contact bridge K1 (6), refer to section “Replace contacts K1/13 and K1/14”, page 23 and “Replace contact bridge K1 and pressure springs”, page 24.
5. Check spring mechanism (7) of contact bridge K1 (6) for free movement.
 - When the contact bridge (6) sticks, clean the bearing spots (8) and the axles (9).
 6. Check contact springs (7) for spring fracture and fatigue.
 - Replace damaged parts, refer to section “Replace contacts K1/13 and K1/14”, page 23 and “Replace contact bridge K1 and pressure springs”, page 24.

Replace contacts K1/13 and K1/14

Required tools/Auxiliary equipment

- ▶ Allen wrench size 4
- ▶ Open-end wrench size 10
- ▶ Loctite thread locker, medium strength

Procedure

1. Make sure that the system is electrically disconnected and that all the safety regulations have been fulfilled (refer to section “6.1 Safety”, page 19).

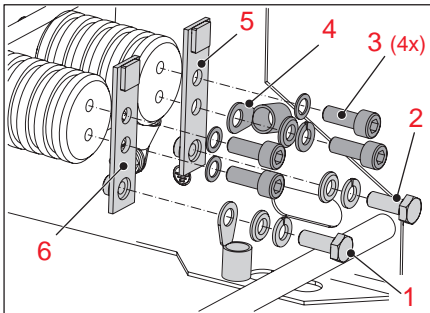

Figure 21

2. Release the hexagon head bolt M6 (2) and slide off the cable lug, serrated lock ring and retaining washer of the coach-side earthing cable, see **Figure 21**.
3. Release the hexagon head bolt M6 (1) and slide off the cable lug, serrated lock ring and retaining washer of the earthing cable to the WA main contact.
4. Release the four Allen screws (3) and remove them with retaining washers as well as the cable lug (4) with serrated lock ring for the housing-earthing cable.
5. Remove the contacts K1/13 (5) and K1/14 (6).
6. Apply Loctite thread locker (medium strength) to the threads of the four Allen screws (3).
7. Attach a new contact K1/13 (5) to the right isolator and tighten it with the two Allen screws (3) and retaining washers. In doing so, also fix the cable lug (4) with serrated lock ring and retaining washer for the housing-earthing cable with the lower screw.
8. Attach a new contact K1/14 (6) to the left isolator and tighten it with the two Allen screws (3) and retaining washers.
9. Arrange the two contacts vertically to the contact bridge so that the silver contact surfaces are superimposable with those of the contact bridge in the closed condition.
10. Connect the cable lug for the earthing cable to the WA main contact with the hexagon head bolt M6 (1), serrated lock ring and retaining washer to the contact K1/14 (6).
11. Connect the cable lug of the coach-side earthing cable with the hexagon head bolt M6 (2), serrated lock ring and retaining washer.

Replace contact bridge K1 and pressure springs

Required tools/Auxiliary equipment

- ▶ Allen wrench size 4

Procedure

1. Make sure that the system is electrically disconnected and that all the safety regulations have been fulfilled (refer to section “**6.1 Safety**”, page 19).
2. Release the two Allen screws (7) and remove them together with retaining washers and the connecting strip bracket complete (8), see **Figure 22**.
3. Install a new connecting strip bracket complete (8) with the two Allen screws (7) and retaining washers to the drive axles of the standard disconnecting and earthing device.

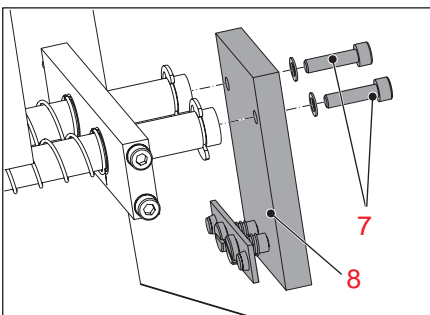

Figure 22

6.5 Drive Unit

Check drive unit

Required tools/Auxiliary equipment

- ▶ Special grease BARRIERTA I SL/OX

The main contact bridge must jump abruptly to the front when the first step of the detent mechanism has been overcome (at 25° opening angle of the lid/door of the switch gear cabinet).

Procedure

1. Make sure that the system is electrically disconnected and that all the safety regulations have been fulfilled (refer to section “**6.1 Safety**”, page 19).
2. Perform a functional check in order to check the jumping performance, refer to section “**5.9 Perform Functional Check**”, page 16.

When the contact bridge moves inertly, slowly, the following components must be checked in order to remedy the cause:

3. Check drive springs (11) for spring fracture or fatigue. Replace damaged drive springs, see **Figure 23**.
4. Check drive axles (12) for abrasion on the bearing surfaces of the detent mechanism. Replace damaged drive axles.
5. Check DU-bushings (13) for ease of movement. Replace the DU-bushings in the case of stiffness.

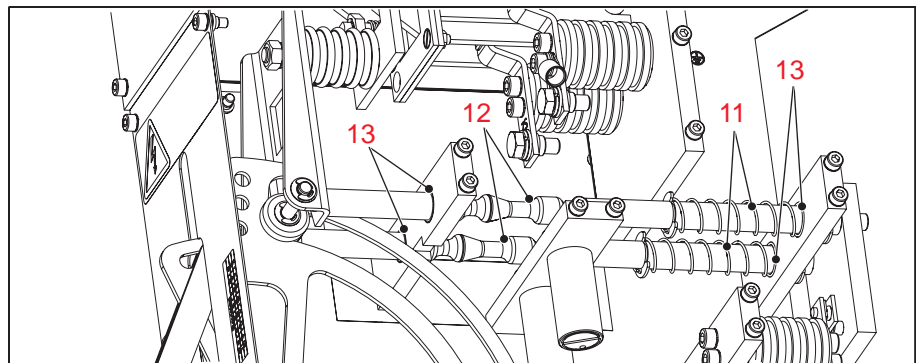

Figure 23

- Check the joints (15, 16, 17, 18) on the link lever (14) for ease of movement. In the case of stiffness, lubricate the joints on the spots (15, 16, 17, 18) with special grease BARRIERTA I SL/OX, see **Figure 24**.

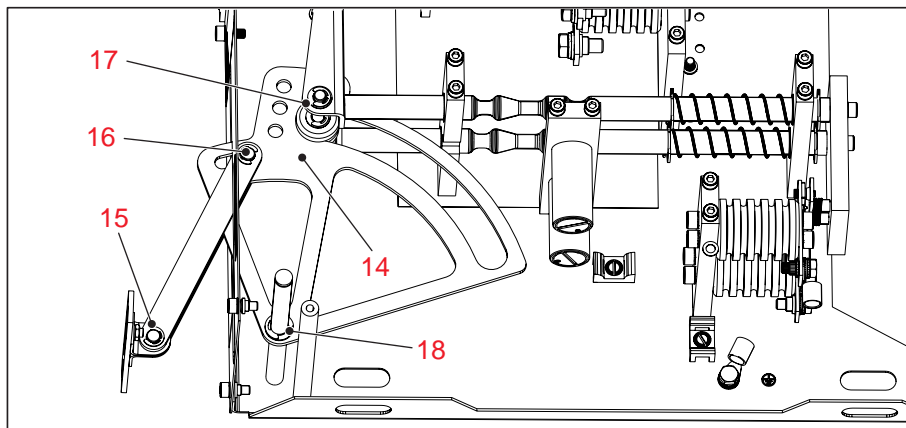

Figure 24

6.6 Detent Mechanism

Check detent mechanism

Required tools/Auxiliary equipment

- ▶ Special grease BARRIERTA I SL/OX

When the lid/door of the switch gear cabinet is opened slightly (opening angle $< 25^\circ$), the main contact bridge must remain closed.

Only when the first step of the detent mechanism has been overcome (25° opening angle of the lid/door), the main contact bridge must abruptly jump to the front.

When the main contact bridge immediately jumps to the front when the lid/door is opened (opening angle $< 25^\circ$), the detent mechanism might have to be adjusted more strongly.

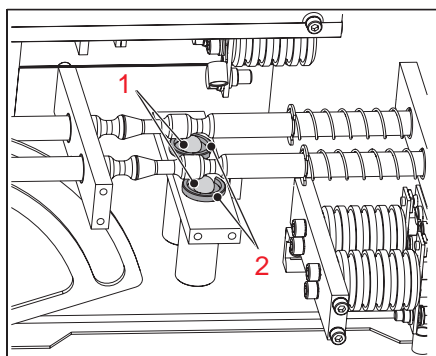

Figure 25

Procedure

- Perform a functional check in order to check the jumping performance of the contact bridge and also to adjust the detent mechanism, refer to section **"5.9 Perform Functional Check"**, page 16.
- If the jumping mechanism of the contact bridge only moves inertly and slowly in spite of the maintenance steps mentioned above having been performed, grease the balls (1) and the ball holders (2) with special grease BARRIERTA I SL/OX, see **Figure 25**.

6.7 Insulation Foil

Check insulation foil

Damaged insulation foils on the inner side may damage the device or lead to failures.

- Check the insulation foils on the inner side of the left and right lateral walls for damages.
- Replace damaged insulation foils.

6.8 Arc Chamber

Check/replace arc chamber

Required tools/Auxiliary equipment

- ▶ Allen wrench size 4

Procedure

1. Make sure that the system is electrically disconnected and that all the safety regulations have been fulfilled (refer to section “**6.1 Safety**”, page 19).
2. Dismount the inspection window (1).
3. Release the two Allen screws (2) and move the front bearing bolt (3) first slightly to the front and then pull it out laterally, see **Figure 26**.

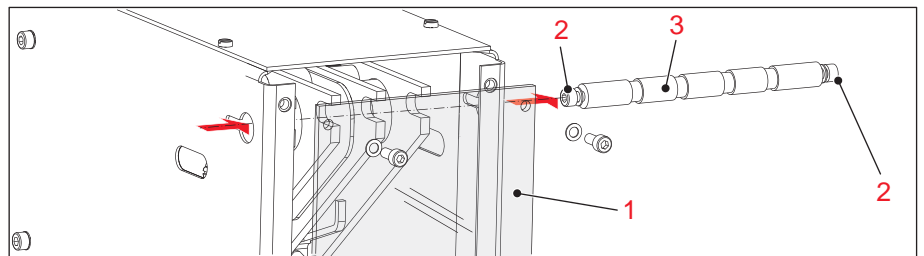

Figure 26

4. Pull out the complete arc chamber (4) to the front, see **Figure 27**.
5. Check all the ceramic parts and magnets of the arc chamber (4) for damages.
6. When parts are damaged, replace the complete arc chamber (4).

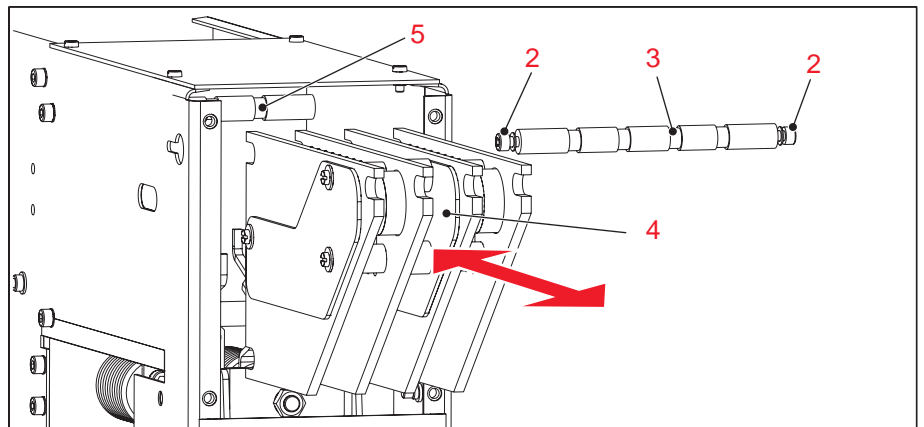

Figure 27

7. In order to reinstall the arc chamber (4), slide it in from the front and insert it into the grooves of the rear bearing bolt (5).
8. Slide in the front bearing bolt (3) laterally, push it slightly to the rear until the arc chamber (4) is arranged correctly in the grooves of the front bearing bolt (3).
9. Tighten the two Allen screws (2).
10. Check the movability of the main contact bridge.
11. Mount the inspection window (1).

7. List of spare parts

Designation	Article no.
Contacts	
Main contact ZS compl.	1-2137-922524
Main contact WA compl.	1-2137-922673
Contact bridge compl.	1-2137-922502
Main contact spring	1-3137-922682
Contact compl.	1-2137-922444
Connecting strip bracket compl.	1-2137-222583
PTFE-coated glass fabric	1-4981-799186
Locking caps f. screws (4 pieces)	1-5957-965678
Arc chamber standard disconnecting and earthing device	1-1137-922251
Drive unit mechanics	
Link lever	1-3137-153705
Axial pin	1-3137-922320
Coupling pin	1-3137-922433
Needle-roller bearing NKI 7/12 TN	1-5901-973328
Detent mechanism	
Special grease BARRIERTA I SL/OX	1-4931-880191

8. Technical Data

Maximum load Disconnecting contact/ Earthing contact	250 kW / 250 kW		
No of disconnecting contacts	1		
No of earthing contacts	1, optional +2 or +4		
Nominal switching voltage U_{nom} Frequency f Continuous thermal current I_{th}	according UIC 550		
Disconnecting contact	U_{nom}	f	I_{th}
	1.0 kV AC	16 2/3 Hz	150 A
	1.5 kV AC	50 Hz	100 A
	1.5 kV DC	---	100 A
	3.0 kV DC / U_{max} 5.0 kV	---	50 A
Earthing contact	3.0 kV DC / U_{max} 5.0 kV	---	50 A
Arc quenching	Arc chamber, permanent-magnetic blowout		
Insulation, Testing voltage U_{Test}	14 kV		
Cycles, mechanical life	approx. 1000, min. 30 years		
Application range	Single- and Multivoltage vehicles		
Temperature range	-40 °C ... +85 °C		
Mounting position	horizontal, vertical (see installation instructions)		
Shock and vibration resistance	EN 61373 (Issue Nov. 1999) Cat.1 Cl.B		
Protection	IP00		
Pollution degree	IP00 / PD 3		
Weight	11 kg		
Dimensions (width x height x depth)	(145 x 415 x 455) mm		
Terminals	Disconnecting contacts (ZS, WA)	M8	
	Earthing contacts (PE)	M6	
	Housing (⊕)	M6	

Schaltbau GmbH

For detailed information on our products and services visit our website – or give us a call!

Schaltbau GmbH
Hollerithstrasse 5
81829 Munich
Germany



Phone +49 89 9 30 05-0
Fax +49 89 9 30 05-350
Internet www.schaltbau.com
e-Mail contact@schaltbau.de

with compliments:



The production facilities of Schaltbau GmbH have been IRIS certified since 2008.



Certified to DIN EN ISO 14001 since 2002. For the most recent certificate visit our website.



Certified to DIN EN ISO 9001 since 1994. For the most recent certificate visit our website.

Electrical Components and Systems for Railway Engineering and Industrial Applications

Connectors

- Connectors manufactured to industry standards
- Connectors to suit the special requirements of communications engineering (MIL connectors)
- Charging connectors for battery-powered machines and systems
- Connectors for railway engineering, including UIC connectors
- Special connectors to suit customer requirements

Snap-action switches

- Snap-action switches with positive opening operation
- Snap-action switches with self-cleaning contacts
- Enabling switches
- Special switches to suit customer requirements

Contactors

- Single and multi-pole DC contactors
- High-voltage AC/DC contactors
- Contactors for battery powered vehicles and power supplies
- Contactors for railway applications
- Terminal bolts and fuse holders
- DC emergency disconnect switches
- Special contactors to suit customer requirements

Electrics for rolling stock

- Equipment for driver's cab
- Equipment for passenger use
- High-voltage switchgear
- High-voltage heaters
- High-voltage roof equipment
- Equipment for electric brakes
- Design and engineering of train electrics to customer requirements