

1

Connectors

SB series

Circular connectors for
special applications

Installation and maintenance
instructions

Manual A30-M.en

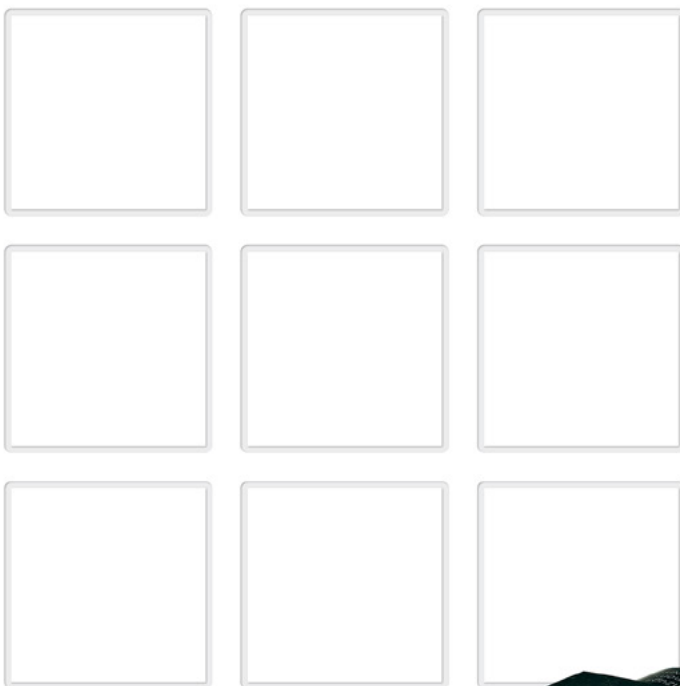

Contents

1. Important Basic Information	3
1.1 Legal Notes	3
1.2 Conventions for this Installation and Maintenance Instructions	3
2. General and Security Information	4
2.1 Observing the Installation and Maintenance Instructions	4
2.2 User Obligations	4
2.3 Proper Use	4
2.4 Improper Use	5
2.5 Ambient Conditions	5
3. Dangers and Security Measures	5
3.1 Electrical Dangers	5
3.2 Risk of Damage	5
4. Description	6
5. Installation	7
5.1 Check Parts for Transport Damage	7
5.2 Preparation of Mounting Holes	8
5.3 Details Regarding Solder Contacts – Crimp Contacts	8
5.4 Connection Solder Contacts	9
5.5 Connection Crimp Contacts	10
5.6 Assembly of the Contact Insert	12
5.6.1 Assembly at the Construction Site with Mobile Assembly Pliers	12
5.6.2 Assembly in the Workshop with Toggle Press	14
5.7 Assembly of the Connection	16
6. Maintenance	17
6.1 Maintenance Intervals	17
6.2 Visual Inspection at Each Plugging	18
7. Specifications	19

1. Important Basic Information

1.1 Legal Notes

Without prior written consent of Schaltbau GmbH, the installation and maintenance instructions is not allowed to be electronically or mechanically reproduced – as a whole or in parts – be distributed, changed, transmitted, translated into another language or used in any other way. Schaltbau GmbH cannot be held liable for damage caused by not observing (or only partly observing) the Installation and maintenance instructions.

1.2 Conventions for this Installation and Maintenance Instructions

This instructions describe the installation and maintenance of the SB connectors.

Cross references in this instructions are presented in ***bold italics***.

To highlight particularly important safety instructions and other information, the following symbols are used in this installation and maintenance instructions:

DANGER

Indicates a hazardous situation with a high level of risk which, if not avoided, will result in death or serious injury.

WARNING

Indicates a hazardous situation with a medium level of risk which, if not avoided, could result in death or serious injury.

CAUTION

Indicates a hazardous situation with a low level of risk which, if not avoided, may result in minor or moderate injury.

NOTICE

Indicates a hazardous situation which, if not avoided, may result in property damage, such as service interruption or damage to equipment or other materials.



Refers to technical features and methods aimed at facilitating work or to particularly important information.

2. General and Security Information

The connectors described here are part of a low voltage system for special applications. They have been designed and checked in accordance with approved engineering regulations. Electrical equipment can generally cause severe harm to one's health and also material damage if used or operated improperly, or if not maintained sufficiently. The maintenance and installation instructions for the connectors must therefore be strictly followed.

Any uncertainties must be clarified and all queries must include details of the type of device and the serial number. The planning and carrying out of mechanical and electrical installations, transportations, assemblies and commissioning as well as maintenance and repair work during installation, operation and maintenance, must therefore only be carried out by responsible experts with the appropriate expertise.

This also applies to adherence to the general assembly and security regulations regarding electric power installations, as well as the correct use of certified tools. Electrical devices are to be protected, as much as possible, from dust and moisture during maintenance or storage.

2.1 Observing the Installation and Maintenance Instructions

- ▶ All staff must read and understand the instructions and adhere to them when working with the device.
- ▶ **Always carefully observe all safety warnings!**

2.2 User Obligations

- ▶ Observe all applicable national regulations, all safety, injury and environmental precautions as well as the recognised technical regulations with regards to safe and professional work.
- ▶ The proper functioning of all available protection and safety devices is to be checked regularly
- ▶ Work on electrical devices must only be carried out by experts or by instructed persons under the guidance and supervision of an expert according to the electro-technical regulations.
- ▶ An expert is a person who can judge and recognise the possible dangers of the jobs commended to him based on his training, knowledge and experience and by knowledge of the appropriate regulations.
- ▶ Staff must be informed clearly about who is responsible for the maintenance of the connectors.

2.3 Proper Use

- ▶ According to IEC 61984, connectors are components which must not be plugged or unplugged when voltage is present during intended use.

2.4 Improper Use

- ▶ The connectors must not be converted or otherwise modified without prior written consent of Schaltbau GmbH. Violations against this will result in the exclusion of liability on the part of the manufacturer.
- ▶ None of the operating conditions defined in our catalogue A30.en in section „Specifications“, such as voltages, currents, or ambient conditions, etc. may be changed.
- ▶ Work on the connectors must only be carried out by staff who meets the requirements set out in these installation and maintenance instructions.
- ▶ The bridging of switches or other control devices is prohibited.

2.5 Ambient Conditions

NOTICE

The connectors are constructed for specific ambient conditions.

- ▶ Use the connectors only under the ambient conditions as defined in our catalogue A30.en in section „**Specifications**“.

3. Dangers and Security Measures

3.1 Electrical Dangers



⚠ DANGER

The connectors contain live voltage components. There is a risk of electric shock!

Always consider the following safety rules before carrying out work on the connectors:

- ▶ Disconnect.
- ▶ Ensure that it is not possible to reconnect unintentionally.
- ▶ Make sure that there is no voltage present.

3.2 Risk of Damage

NOTICE

Improper handling of the connectors, e.g. when hitting the floor with some impact, can result in breakage, cracks and deformation.

- ▶ Make sure that the connectors are always used properly.
- ▶ Regularly sight-check the connectors for potential damages.
- ▶ Immediately replace damaged components.

4. Description

Connectors of the SB-series are circular connectors for special applications. They are particularly designed for operation locations in rail vehicles, where harsh ambient conditions have to be handled in daily operation.

The connectors are permanently resistant to harsh weather conditions as they are equipped with silver plated or gold plated contacts in rubber sealed contact inserts.

The connectors are typically used for systems and components that require high reliability and safety. This is why the SB-connectors are, for instance, used

- ▶ as supply line and control cable connectors for train protection systems installed in bogies of railway vehicles;
- ▶ as special connectors for harsh industrial applications.

The connectors of the SB-series have a modular structure and are available in different versions, each as flange socket with the corresponding connector.

Overview SB-series – flange sockets and connectors

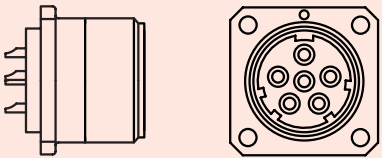
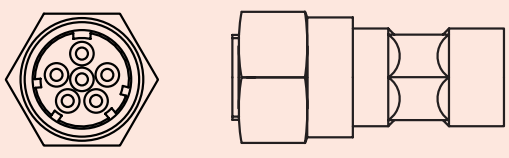
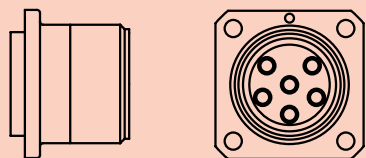
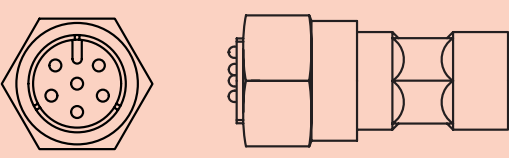
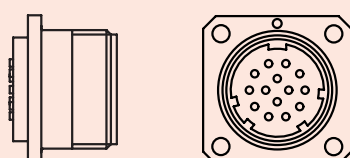
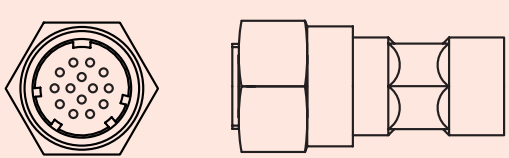
Number of poles	Flange sockets	Connectors
5-pole + PE (protective conductor)	 <p>5 + PE pin contact Solder terminal: silver</p>	 <p>5 + PE socket contact - Solder terminal: silver - Crimp terminal: silver</p>
6-pole	 <p>6x socket contact Solder terminal: silver or gold</p>	 <p>6x pin contact - Solder terminal: silver or gold - Crimp terminal: silver or gold</p>
14-pole	 <p>14x pin contact Crimp terminal: silver</p>	 <p>14x socket contact Crimp terminal: silver</p>

5. Installation



⚠ DANGER

The connectors contain live voltage components. There is a risk of electric shock!

Always consider the following safety rules before carrying out work on the connectors:

- ▶ Disconnect.
- ▶ Ensure that it is not possible to reconnect unintentionally.
- ▶ Make sure that there is no voltage present.

NOTICE

During installation, ensure that dirt caused by surrounding construction activities does not get into the connectors.

5.1 Check Parts for Transport Damage

NOTICE

If parts are damaged, the functional reliability of the connectors is no longer given.

- ▶ Before installation, check all parts for any possible transport damage.
- ▶ Do not install any damaged parts.

5.2 Preparation of Mounting Holes

Dimensions

The precise dimensions of the respective connectors and the flange socket versions are indicated in the respective data sheets or in our catalogue A30.en.

Mounting holes

For the assembly of the flange socket, a mounting hole as shown in the drawing below is required.

The flange socket has to be fixed with four M5 screws.

Tightening torque: Determined by the user, in consideration of the materials used for the construction

Length of the screws: In consideration of the assembly situation

The dimensions and the arrangement of the mounting holes are both shown in the drawing below.

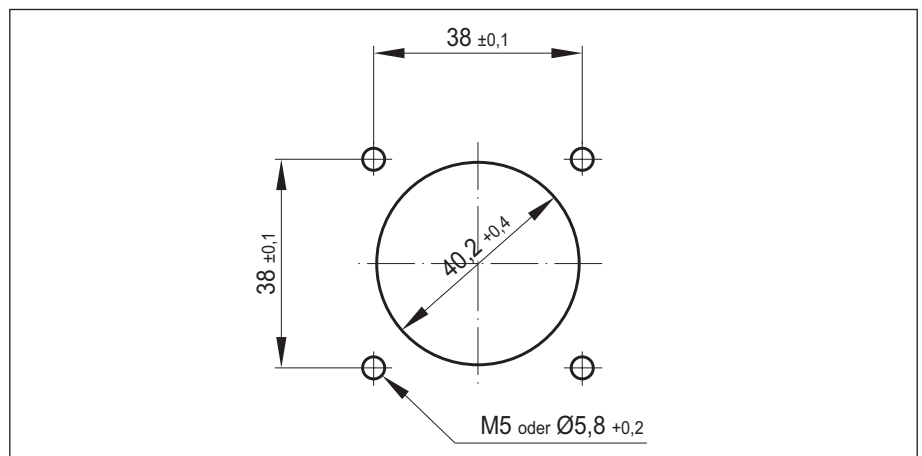

Dimensions and arrangement of the mounting holes (Dimensions in mm)

5.3 Details Regarding Solder Contacts – Crimp Contacts

Version solder contacts

Solder contacts are permanently assembled in the contact insert. The cable strands can be soldered directly to the pre-assembled contacts.

Version crimp contacts

Crimp contacts are not yet assembled to any component. When assembling the crimp contacts, the cable strands have to be crimped to the contacts first. Then, the contacts have to be pressed into the contact insert.

5.4 Connection Solder Contacts

Required tools/auxiliary materials

- ▶ Soldering tools
- ▶ Suitable solder
- ▶ Tools for removing insulation

Procedure

- ▶ Strip jacket from cable (1) to a length of approx. 45 mm and the insulation of the stranded wires to approx. 10 mm.
- ▶ Thread cable gland (2) (OEM part, not included in the delivery) and connector shell (3) on the cable (1).
- ▶ Solder the cable strands to the contacts (4) on the contact insert.
- ▶ In the end, check all solder terminals for stable and correct connection.

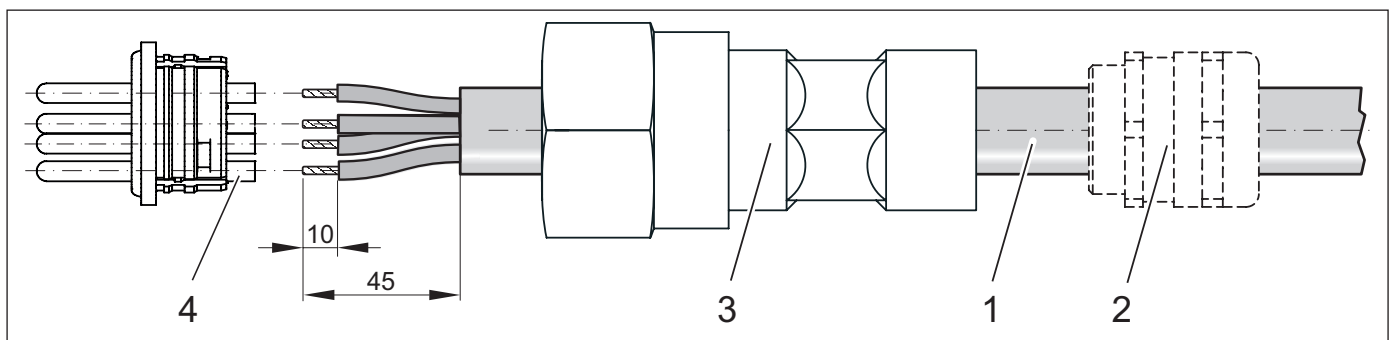

Connection solder contacts (Dimensions in mm)

- ▶ For assembling the contact insert into the connector shell, see „5.6 Assembly of the contact insert“.

5.5 Connection Crimp Contacts

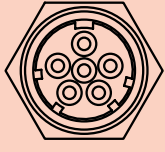
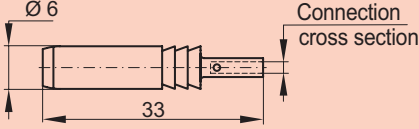
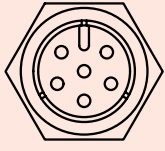
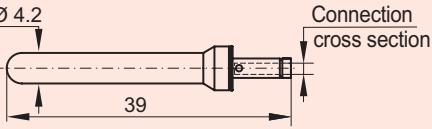
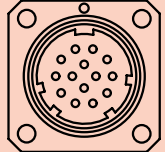
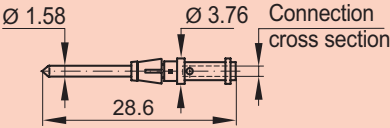
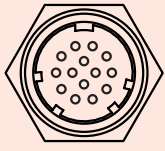
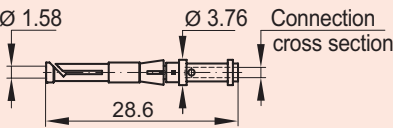
Overview crimp contacts			
Number of poles	Contact type	Ordering code	Connection cross section
 5-pole + PE	Socket contact for connector 	B 4,2C 1,5 AG	1.5 mm ²
 6-pole	Pin contact for connector 	Pin 4,2 C 0,75-1 SZC-1,50-Au Pin	0.75 ... 1 mm ² 1 ... 1.5 mm ²
 14-pole	Pin contact for flange socket 	SAC-0,50-Ag SAC-1,00-Ag SAC-1,50-Ag SAC-2,50-Ag	0.5 mm ² 0.75 ... 1 mm ² 1.5 mm ² 2.5 mm ²
 14-pole	Socket contact for connector 	BAC-0,50-Ag BAC-1,00-Ag BAC-1,50-Ag BAC-2,50-Ag	0.5 mm ² 0.75 ... 1 mm ² 1.5 mm ² 2.5 mm ²

(Dimensions in mm)

Required tools/auxiliary materials

- ▶ Crimp tool for cross-section of connection 0.14 mm² ... 6 mm² (Ordering code: CWZ-600-1)
- ▶ Insertion tools for crimp contacts:
 - Insertion tool for pin contacts and socket contacts B 4,2C 1,5 AG, Pin B 4,2 C 0,75-1 and SZC-1,50-Au Pin (Ordering code: EWZ-4,2)
 - Insertion tool for pin contacts and socket contacts SAC xxx-AG and BAC-xxx-AG (Ordering code: EWZ-A)
- ▶ Tools for removing insulation

Procedure

The connection of the crimp contacts has to be carried out in accordance with DIN EN 60352-2 – solderless connections.

- ▶ Strip jacket from cable (1) to a length of approx. 45 mm and the insulation of the stranded wires to approx. 8 mm.
- ▶ Thread cable gland (2) (OEM part, not included in the delivery) and connector shell (3) on the cable (1).
- ▶ Crimp cable strands with crimp tool to the contacts (4).
 - While doing so, consider the cross-sections of the connection, respective to the version of crimp contacts (see table „Overview crimp contacts“).
 - The crimping has to be carried out midway between the inspection hole and the end of the contact (see drawing below).
- ▶ Check crimp terminals for stable and correct connection.
 - Make sure that no single strands stick out.
 - Check extraction forces according to DIN EN 61238-1.
- ▶ The crimp contacts have to be inserted in the contact insert starting in the middle and moving outwards:
 - While doing so, every single crimp contact (4) has to be pressed into the contact insert (5) with the insertion tool, until the contact clearly engages.



The respective data sheets show how far exactly the contacts stick out of the contact insert.

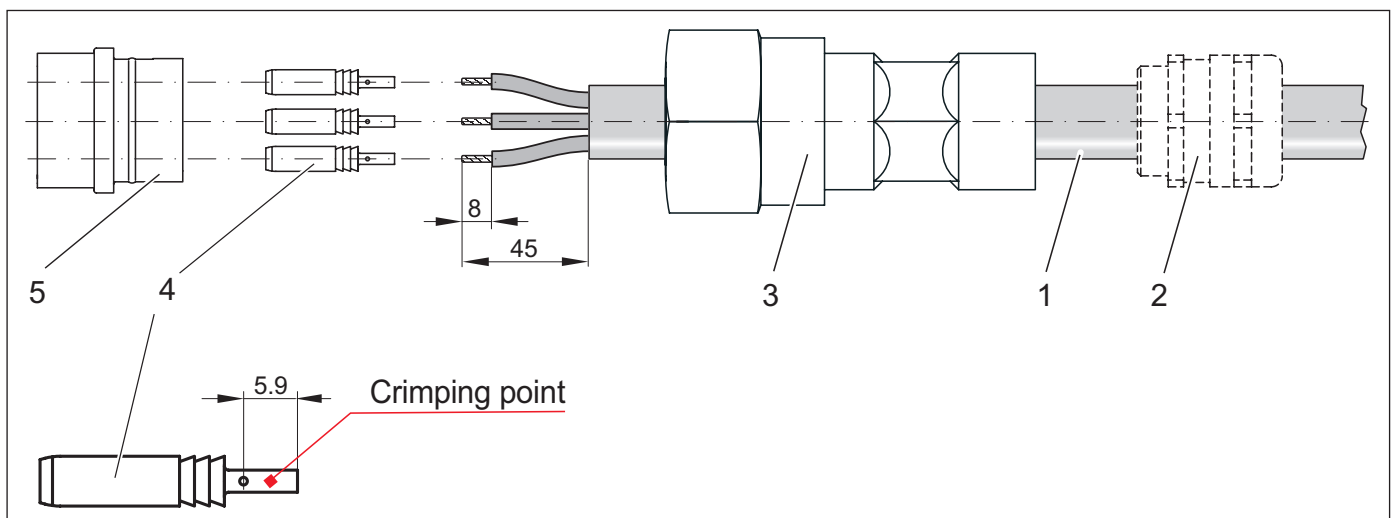

Connection Crimp contacts (Dimensions in mm)

- ▶ For assembling the contact insert into the connector shell, see „5.6 Assembly of the contact insert“.

5.6 Assembly of the Contact Insert

When all the connections have been established on the contacts, the contact insert has to be pressed into the connector shell. This can be done either with the mobile assembly pliers – directly on-site at the construction site – or stationary in the workshop.

5.6.1 Assembly at the Construction Site with Mobile Assembly Pliers

Required tools/auxiliary materials

- ▶ Mobile assembly pliers (A) with mounting mandrel (B) (Ordering code: EDZ-ST)
- ▶ Ethyl alcohol as lubricant

Procedure

- ▶ Push the connector shell (D) to the completely wired contact insert (C).
- ▶ Moisten the contact insert (C) on the circumference with ethyl alcohol.

NOTICE

Lubricants which do not evaporate, cause the contact insert to slip out of the connector shell.

- ▶ Do not use other lubricants, such as greases, oils, etc.
- ▶ Do only use ethyl alcohol as lubricant.

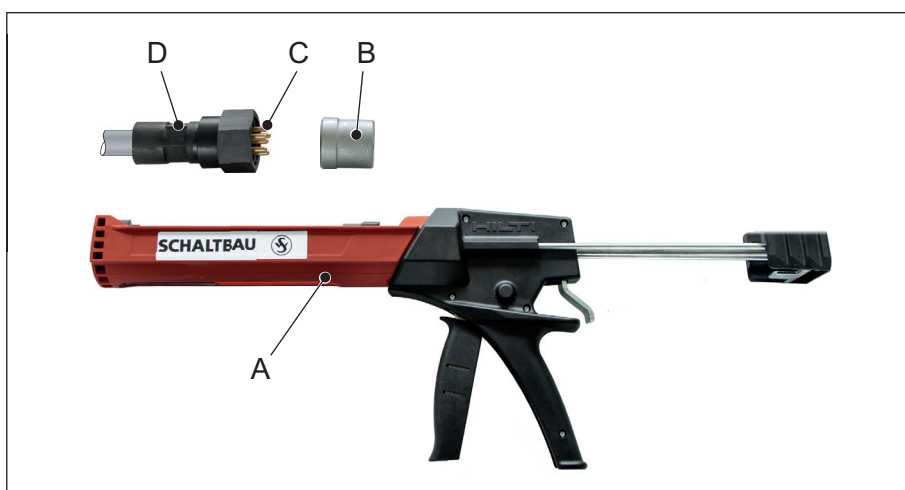

Mobile assembly pliers (A) with mounting mandrel (B) to mount the contact insert (C) into the connector shell (D)

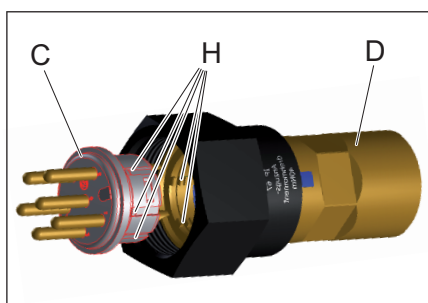

Slots and guides on the contact insert and on the connector shell.

- ▶ Set the contact insert (C) onto the connector shell (D) so that the slots (H) of the contact insert and the guides (H) on the connector shell are congruent.

Note: The fivefold coding (H) prevents improper assembly.

- ▶ Manually push the contact insert (C) into the connector shell (D) as far as possible.

- ▶ Put the pre-assembled contact insert (C) and the connector shell (D) with the cable into the assembly pliers.
- ▶ Put the mounting mandrel (B) into the holder (G) of the assembly pliers – As for pin contacts, make sure that the mounting mandrel is being mounted in correct position in accordance with the arrangement of the contacts.
- ▶ Adjust the locating shoulder of the connector shell (E) so that it lays firmly on the locating shoulder of the assembly pliers (F).

NOTICE

In order to prevent damages to the components, make sure that before and during pressing the contact insert,

- ▶ the mounting mandrel and the contact insert in the connector shell are laying on the same press axis;
- ▶ the locating shoulder of the connector shell (E) does not lift off of the locating shoulder of the assembly pliers (F).

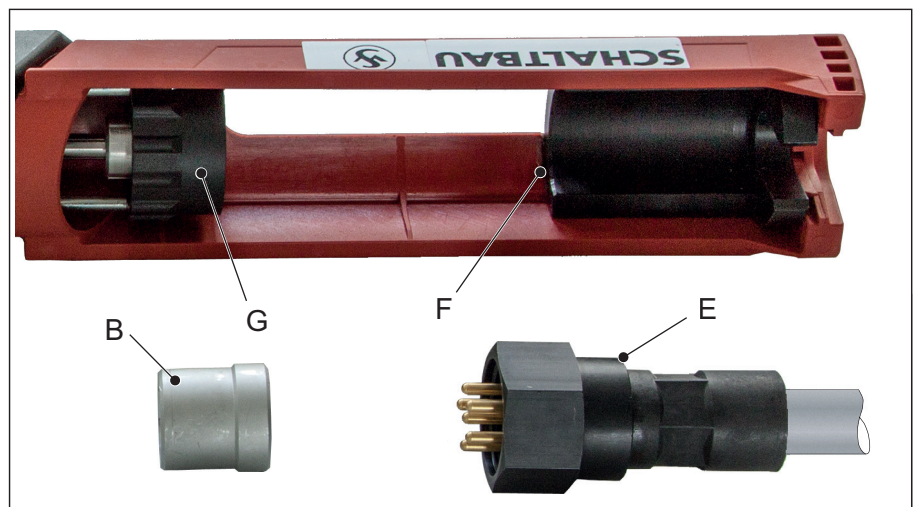

Inserting the pre-assembled connector into the assembly pliers

- ▶ In order to press the contact insert into the connector shell, press the handles of the assembly pliers several times until the contact insert (C) completely engages into the connector shell (D).

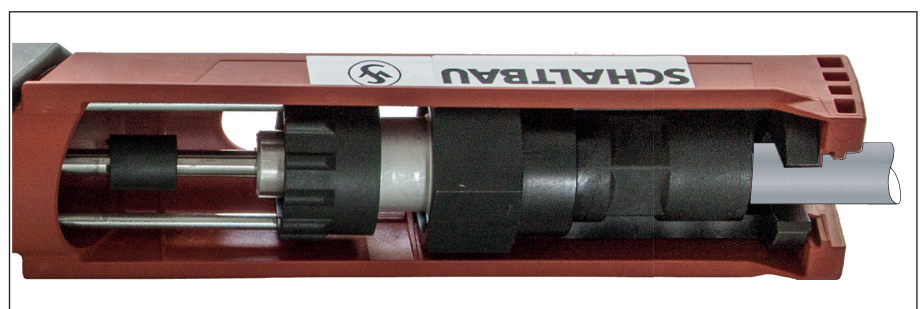

Contact insert completely pressed into connector shell with assembly pliers

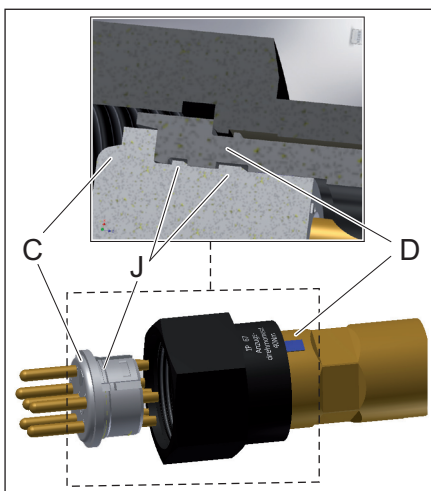

Engage contours of the contact insert

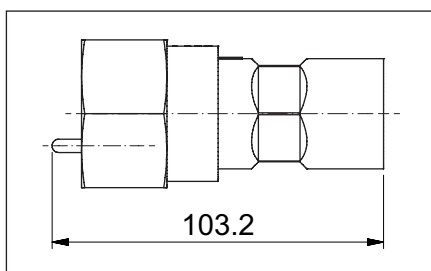

Target distance between contact tip and the end of the connector shell



EWZ-6P Insertion tool

Check

- ▶ Check whether the engage contours (J) of the contact insert (C) are completely engaged into the connector shell (D), by measuring the distance between the contact tip and the end of the connector shell (target distance 103.2 mm, see drawing on the left).

NOTICE

If the contact insert does not completely engage, it can slip out of the connector shell during plugging or unplugging.

If the contact insert has not completely engaged:

- ▶ Readjust the assembly pliers and press the contact insert with the mounting mandrel again until the distance between the contact tip and the end of the connector shell is 103.2 mm.

5.6.2 Assembly in the Workshop with Toggle Press

Required tools/auxiliary materials

- ▶ Insertion tool for contact inserts (Ordering code: EWZ-6P)
- ▶ Toggle press
- ▶ Suitable contact surface for the connector shell with cable recess
- ▶ Ethyl alcohol as lubricant

Procedure

- ▶ Push the connector shell (D) to the completely wired contact insert (C).
- ▶ Moisten the contact insert (C) on the circumference with ethyl alcohol.

NOTICE

Lubricants which do not evaporate, cause the contact insert to slip out of the connector shell.

- ▶ Do not use other lubricants, such as greases, oils, etc.
- ▶ Do only use ethyl alcohol as lubricant.

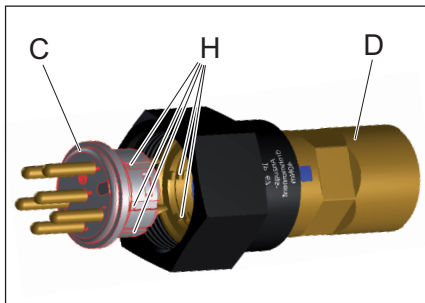

Slots and guides on the contact insert and on the connector shell.

- ▶ Set the contact insert (C) onto the connector shell (D) so that the slots (H) of the contact insert and the guides (H) on the connector shell are congruent.

Note: The fivefold coding (H) prevents improper assembly.

- ▶ Manually push the contact insert (C) into the connector shell (D) as far as possible.
- ▶ Put the connector shell with the cable side onto the prepared contact surface so that the cable route is guided in the cable recess without being crushed.
- ▶ Clamp the insertion tool into the toggle press – As for pin contacts, make sure that the insertion tool is being clamped in correct position in accordance with the arrangement of the contacts.

NOTICE

In order to prevent damages to the components, make sure that before and during pressing the contact insert, the insertion tool and the contact insert in the connector shell are laying on the same press axis.

- ▶ Press the contact insert (C) into the connector shell (D) with the insertion tool and the toggle press until the contact insert completely engages.

Check

- ▶ Check whether the engage contours (J) of the contact insert (C) are completely engaged into the connector shell (D), by measuring the distance between the contact tip and the end of the connector shell (target distance 103,2 mm, see drawing on the left).

NOTICE

If the contact insert does not completely engage, it can slip out of the connector shell during plugging or unplugging.

If the contact insert has not completely engaged:

- ▶ Readjust the toggle press and press the contact insert with the insertion tool again until the distance between the contact tip and the end of the connector shell is 103,2 mm.

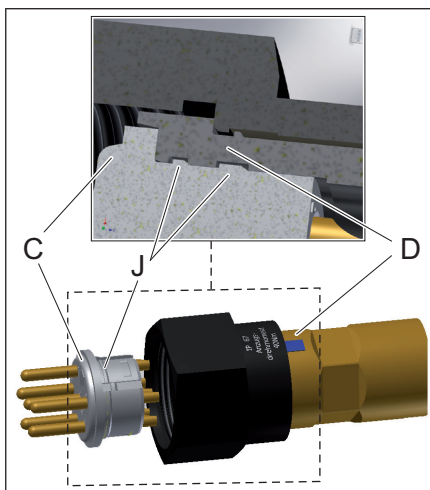

Engage contours of the contact insert

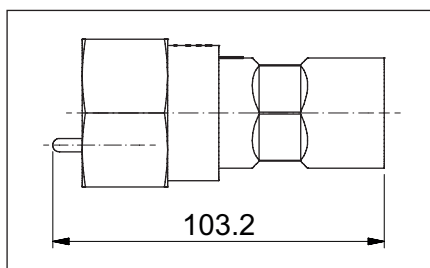

Target distance between contact tip and the end of the connector shell

5.7 Assembly of the Connection

Required tools/auxiliary materials

- ▶ Open-end spanner, AF (across flats) 30 and 46

Procedure

NOTICE

Torsional forces on the contact insert can damage the connector.

- ▶ Always use the hexagon AF (across flats) 30 on the connector shell as counter support when assembly operations could exert torsional forces on the contact insert.

- ▶ Screw in the cable gland (2) (OEM part, not included in the delivery) into the connector shell (3). While doing so, use the hexagon AF (across flats) 30 on the connector shell with the open-end spanner as counter support in order to prevent torsional forces on the cable strands.
- ▶ If necessary, lubricate the thread of the union nut (4) / flange socket (5).
- ▶ In order to establish the connection, plug the connector into the flange socket (5).
- ▶ Screw on and tighten the union nut (4).
Torque: 35 Nm up to max. 40 Nm.
- ▶ In the end, check all components for correct connection and tight seat.

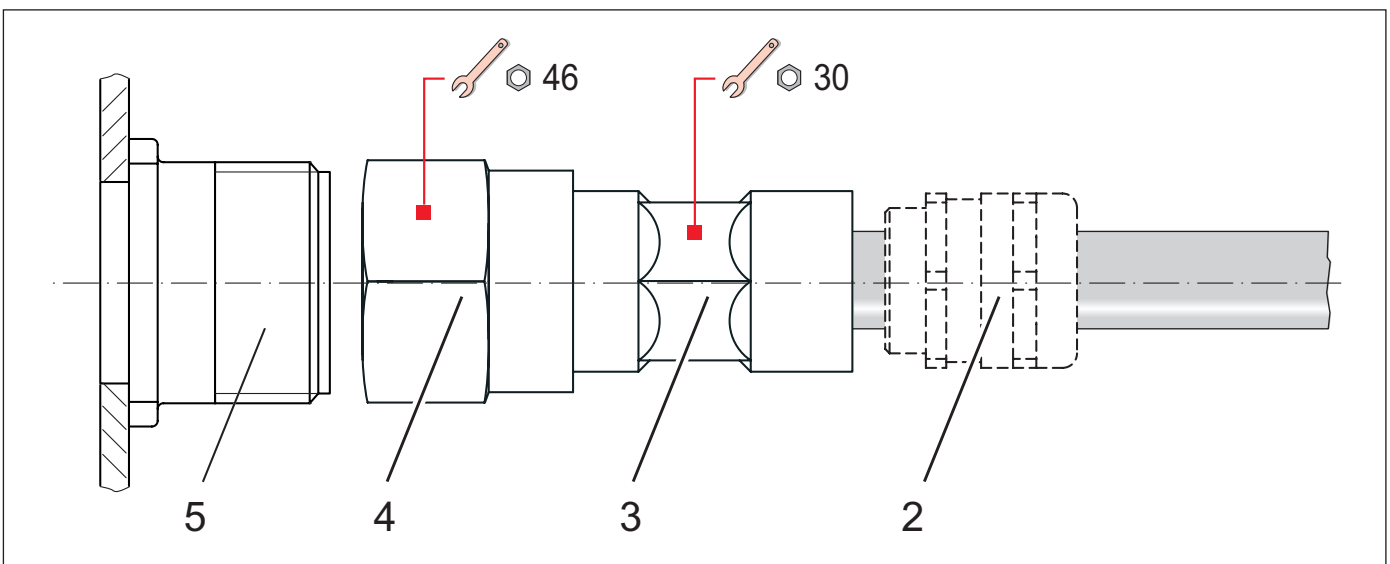

Assembly of the connection

6. Maintenance

Note the expert knowledge which is essential for carrying out maintenance work, mentioned in chapter: „**2. General and Security Information**“.

	⚠ DANGER
	<p>The connectors contain live voltage components. There is a risk of electric shock!</p> <p>Always consider the following safety rules before carrying out work on the connectors:</p> <ul style="list-style-type: none"> ▶ Disconnect. ▶ Ensure that it is not possible to reconnect unintentionally. ▶ Make sure that there is no voltage present.

The following is a list of maintenance work which may be carried out on the connectors, by a trained specialist.

6.1 Maintenance Intervals

The state of the connectors is dependent on environmental conditions. To ensure the correct function and prolonged operational life span of the connectors, the following checks and maintenance must be performed regularly:

Test / Maintenance	Interval
Visual inspection of - Connector - Cable - Union nut - Flange socket - Contacts - Contact insert	▶ At each plugging

6.2 Visual Inspection at Each Plugging

At each plugging, the connectors with cable, the flange socket and all plug contacts and socket contacts have to be visually inspected.

NOTICE

In case of visible damages to cable, connectors, flange socket, contacts or contact inserts, the functional safety of the connection is no longer given.

- ▶ Immediately replace all damaged components.

Connector-element	Visual inspection and function check	Measures
Connector	Check for: <ul style="list-style-type: none"> ▶ Ease of movement during plugging ▶ Dirt ▶ Visible damages to connector shell, contacts, contact insert ▶ Loose or missing fastening elements 	In case of defects: <ul style="list-style-type: none"> ▶ Remove potential dirt (abrasion of the contact surfaces), e.g. with compressed air or a nylon brush. ▶ Immediately replace defective components ▶ Repair the elements
Union nut on the connector	Check for: <ul style="list-style-type: none"> ▶ Ease of movement of the thread ▶ Damage to the thread 	In case of defects: <ul style="list-style-type: none"> ▶ Immediately replace defective components ▶ If necessary, lubricate the thread
Flange socket	Check for: <ul style="list-style-type: none"> ▶ Ease of movement during plugging ▶ Dirt ▶ Visible damages to socket shell, contacts, contact insert ▶ Loose or missing fastening elements ▶ Damage to the thread 	In case of defects: <ul style="list-style-type: none"> ▶ Remove potential dirt (abrasion of the contact surfaces), e.g. with compressed air or a nylon brush. ▶ Immediately replace defective components ▶ Repair the elements

7. Specifications

Specifications and information on the material characteristics for the connectors of the SB-series are given in our catalogue A30.en.

Schaltbau GmbH

For detailed information on our products and services visit our website – or give us a call!

Schaltbau GmbH
Hollerithstrasse 5
81829 Munich
Germany



Phone +49 89 9 30 05-0
Fax +49 89 9 30 05-350
Internet www.schaltbau.com
e-Mail contact@schaltbau.de

with compliments:



The production facilities of Schaltbau GmbH have been IRIS certified since 2008.



Certified to DIN EN ISO 14001 since 2002. For the most recent certificate visit our website.



Certified to DIN EN ISO 9001 since 1994. For the most recent certificate visit our website.

Electrical Components and Systems for Railway Engineering and Industrial Applications

Connectors

- Connectors manufactured to industry standards
- Connectors to suit the special requirements of communications engineering (MIL connectors)
- Charging connectors for battery-powered machines and systems
- Connectors for railway engineering, including UIC connectors
- Special connectors to suit customer requirements

Snap-action switches

- Snap-action switches with positive opening operation
- Snap-action switches with self-cleaning contacts
- Snap-action switch made of robust polyetherimide (PEI)
- Snap-action switch with two galvanically isolated contact bridges
- Special switches to suit customer requirements

Contactors Emergency disconnect switches

- Single and multi-pole DC contactors
- High-voltage AC/DC contactors
- Contactors for battery powered vehicles and power supplies
- Contactors for railway applications
- Terminal bolts and fuse holders
- DC emergency disconnect switches
- Special contactors to suit customer requirements

Electrics for rolling stock

- Equipment for driver's cab
- Equipment for passenger use
- High-voltage switchgear
- High-voltage heaters
- High-voltage roof equipment
- Equipment for electric brakes
- Design and engineering of train electrics to customer requirements