

3

Contactors

EKS127 series

Terminal bolts

Catalogue B100.en

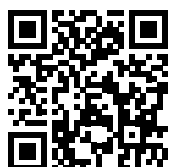

More information
schaltbau.com

EKS 127 Terminal bolts for low voltage applications

Single terminal bolts from Schaltbau are easily incorporated in assemblies of switchgear and control panels for the purpose of electrical termination. They are designed for amperages and voltages applicable to electrical equipment used on rolling stock or material handling vehicles.

EKS127 series terminal bolts can be used as individual terminals or mounted onto a rail to form a terminal block, where connections are made by cable lugs, terminal tags, or bus bar. They are also suitable as insulated mounting support for switching elements or in other electrical components.

Applications

- Mounting and distribution panels
- Terminal blocks
- Keylock switches
- Emergency disconnect switches

Features

- 4 different sizes available
- Rugged Design
- Fastened with 2 M4 screws or mounting on rail
- Base of terminal bolt flame retardant to UL 94 V-0

Specifications EKS127 a /N, EKS127 b /N, EKS127 c /N, EKS127 d /N



Photo: Schaltbau

S135 Series emergency disconnect switch: Two terminal bolts are used for electrical connection as well as mechanical connection between switching mechanism and cam-operated switching element.

Specifications									
Materials Base Terminal bolt	Polyamide, fibre glass reinforced Steel, zinc-plated								
Temperature range	-20°C ... +70°C								
Max. temperature of bolt	120°C								
Rated insulation voltage U_i to IEC 60947-1									
<ul style="list-style-type: none"> • when fastened with 2 M4 screws • when mounted on rail 	<table border="0"> <tr> <td>OV3 / PD3:</td> <td>800 V</td> </tr> <tr> <td>OV3 / PD2:</td> <td>1,000 V</td> </tr> <tr> <td>OV3 / PD3:</td> <td>630 V</td> </tr> <tr> <td>OV3 / PD2:</td> <td>1,000 V</td> </tr> </table>	OV3 / PD3:	800 V	OV3 / PD2:	1,000 V	OV3 / PD3:	630 V	OV3 / PD2:	1,000 V
OV3 / PD3:	800 V								
OV3 / PD2:	1,000 V								
OV3 / PD3:	630 V								
OV3 / PD2:	1,000 V								
Conventional thermal current I_{th}									
<ul style="list-style-type: none"> • EKS127 a /N • EKS127 b /N • EKS127 c /N • EKS127 d /N 	<table border="0"> <tr> <td></td> <td>200 A</td> </tr> <tr> <td></td> <td>300 A</td> </tr> <tr> <td></td> <td>300 A</td> </tr> <tr> <td></td> <td>500 A</td> </tr> </table>		200 A		300 A		300 A		500 A
	200 A								
	300 A								
	300 A								
	500 A								
Mounting									
<ul style="list-style-type: none"> • Single terminal bolt, max. torque • Several bolts in series on rail 	<table border="0"> <tr> <td>with 2 M4 screws</td> <td>1.5 Nm</td> </tr> <tr> <td>with split ring</td> <td></td> </tr> </table>	with 2 M4 screws	1.5 Nm	with split ring					
with 2 M4 screws	1.5 Nm								
with split ring									
Other bolt sizes, max. torque	<table border="0"> <tr> <td>M 8</td> <td>15 Nm</td> </tr> <tr> <td>M 10</td> <td>25 Nm</td> </tr> <tr> <td>M 12</td> <td>30 Nm</td> </tr> </table>	M 8	15 Nm	M 10	25 Nm	M 12	30 Nm		
M 8	15 Nm								
M 10	25 Nm								
M 12	30 Nm								

Ordering code Terminal bolts, split rings, spacer sleeves

- Terminal bolt EKS127 a /N, EKS127 b /N, EKS127 c /N, EKS127 d /N

Ordering code	Bolt	Length	Weight
EKS127 a /N	M 8	20	24 g
EKS127 b /N	M 10	20	31 g
EKS127 c /N	M 10	30	37 g
EKS127 d /N	M 12	45	60 g

- Rail mounting: Split ring for single terminal bolt

Ordering code	for use with Series
HR-abc	EKS127 a /N, EKS127 b /N, EKS127 c /N
HR-d	EKS127 d /N

- Rail mounting: Spacer sleeve

Ordering code	for use with Series
DB-abc	EKS127 a /N, EKS127 b /N, EKS127 c /N
DB-d	EKS127 d /N

Dimension diagram Single terminal bolt, Accessories

- Terminal bolt EKS127 a /N, EKS127 b /N, EKS127 c /N

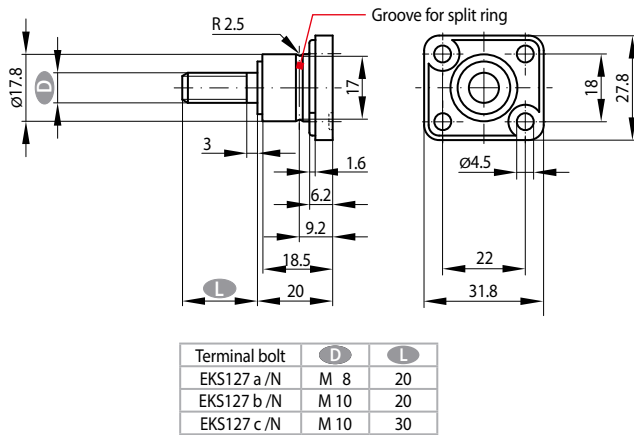

- Split ring HR-abc, HR-d

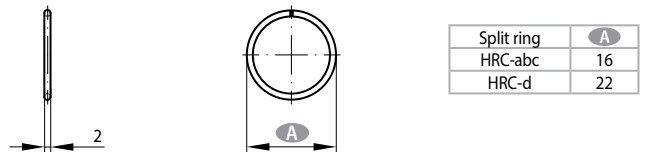

- Spacer sleeve DB-abc, DB-d

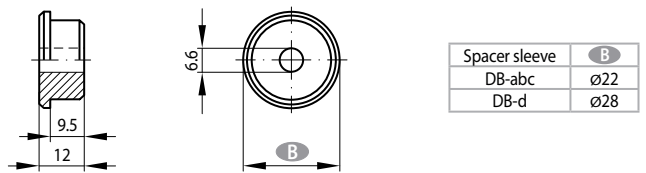

- Terminal bolt EKS127 d /N

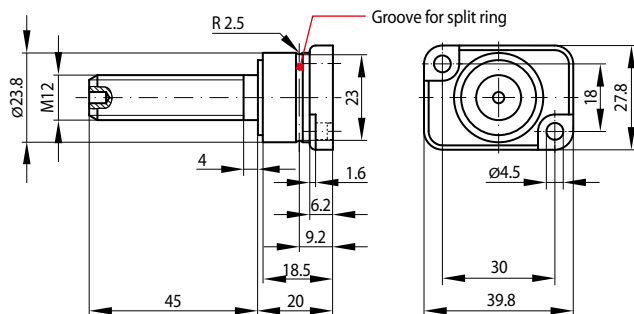

- Rail mounting (Example)

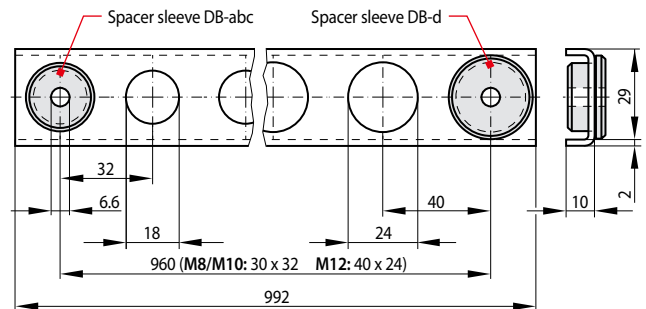

i **Cable lugs** Please observe that the cable lugs must be mounted plane on top of each other.
Bolt size: Please observe the max. torque for the different bolt sizes as detailed in 'Specifications'.

i **Single terminal bolt:** The bolts are fastened with 2 M4 screws. Please observe max. torque: 1.5 Nm.
Rail mounting: The bolt is put through the hole in the rail and its base fixed to the rail by means of a split ring.
 Mounting of rail is done with the help of spacer sleeves DB-abc or DB-d.
 Note: Rails as shown in the diagram are no product of Schaltbau GmbH and must be ordered from commercial suppliers.

Schaltbau GmbH

For detailed information on our products and services visit our website – or give us a call!

Phone +49 89 9 30 05-0
Internet www.schaltbau.de
e-mail contact@schaltbau.de

Find your worldwide contact person. We are here for you, personally!



with compliments:



The production facilities of Schaltbau GmbH have been IRIS certified since 2008.



Certified to DIN EN ISO 14001 since 2002. For the most recent certificate visit our website.



Certified to DIN EN ISO 9001 since 1994. For the most recent certificate visit our website.

Electrical Components and Systems for Railway Engineering and Industrial Applications

Connectors

- Connectors manufactured to industry standards
- Connectors to suit the special requirements of communications engineering (MIL connectors)
- Charging connectors for battery-powered machines and systems
- Connectors for railway engineering, including UIC connectors
- Special connectors to suit customer requirements

Snap-action switches

- Snap-action switches with positive opening operation
- Snap-action switches with self-cleaning contacts
- Snap-action switch made of robust polyetherimide (PEI)
- Snap-action switch with two galvanically isolated contact bridges
- Special switches to suit customer requirements

Contactors Emergency disconnect switches

- Single and multi-pole DC contactors
- High-voltage AC/DC contactors
- Contactors for battery powered vehicles and power supplies
- Contactors for railway applications
- Terminal bolts and fuse holders
- DC emergency disconnect switches
- Special contactors to suit customer requirements

Electrics for rolling stock

- Equipment for driver's cab
- Equipment for passenger use
- High-voltage switchgear
- High-voltage heaters
- High-voltage roof equipment
- Equipment for electric brakes
- Design and engineering of train electrics to customer requirements