

4

Electrics for Rolling Stock

Series K

Toggle switches
for drivers' desks
of rail vehicles

Catalogue F112.en



More information
schaltbau.com



Series K – Toggle switches for drivers' desks of rail vehicles

Rail vehicles in good hands – with toggle switches from Schaltbau

Toggle switch K is the newest member of the Schaltbau toggle switch family expanding the existing product range. Typical applications are drivers' desks of rail vehicles but also control panels of cranes and cable cars. K Series toggle switches can be equipped with up to 8 S880 Series snap-action switches and have 5 switch settings max. and a variety of different

contact positions. Following UIC 612-0 and technologically state-of-the-art these toggle switches are compatible with the ones of the P Series. A ring-shaped LED lighting is available in one or two colours in 5 different colours and integrates separate light indicators and allows an effective night design.

iF product design award



product design award

2012

Schaltbau toggle switch series K has been granted the iF product design award 20012. The award is a recognized seal for excellent product design the world over.

Our toggle switch convinced the international jury with its elegant design and the quality of the materials used. It is already our second award-winning product.

Features

K series

- **Design:** Award winning, elegant, distinctive, high-quality and priced competitively.
- **Handle styles:** Standard handle and special handles to UIC 612-0.
- **Action:** 3 and 5 switch settings, momentary and maintained operation compatible with Schaltbau's other series.
- **Mounting:** Bushing mount, round panel hole. Wiring with cage clamps or via connectors.
- **LED illumination:** Illuminated ring, one or two coloured, as function display and/or backlit illumination. Available in 5 different colours.
- **Shell:** Rugged and durable. Solid and fully sealed plastic shells. Ingress protection rating IP50 max. above mounting plate.
- **Switching elements:** 8 snap-action switches S880 max.

Driver's desk elements

K series

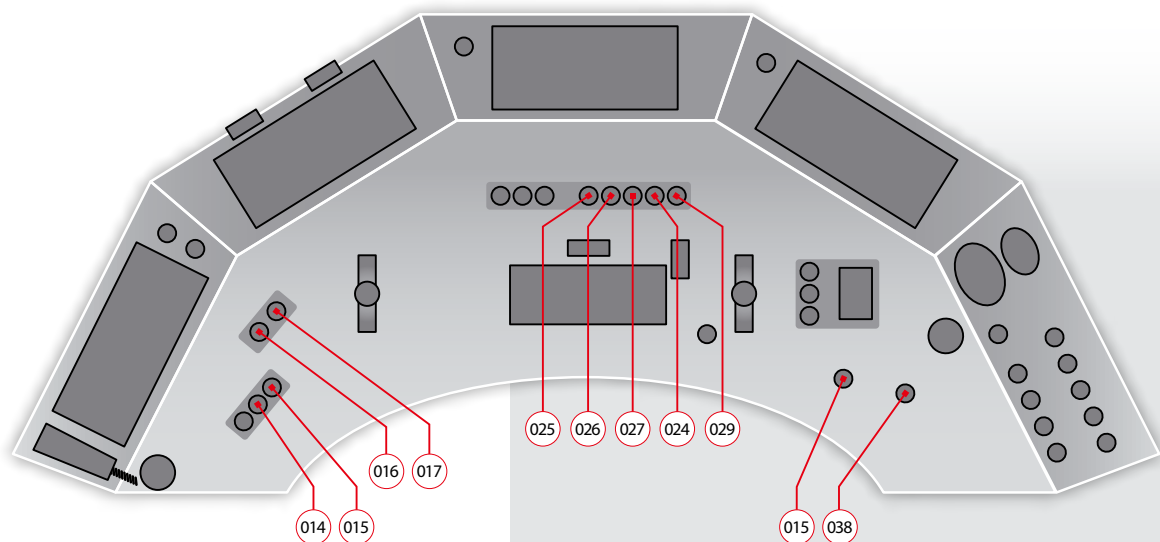

K Series toggle switches in European drivers' desks (EUDDplus project)

The European driver's desk as specified by the EUDDplus project complies with the UIC 612-0 standard, which describes the interface between driver and driver's desk of EMUs, DMUs, locomotives and driving trailers. The project aims at an optimum ergonomic configuration of the desk elements by standardizing and harmonizing their design.

Function	Handle	Settings	Action
014 ETCS release intervention	Standard	3	TKNKT
015 ETCS acknowledgement	Ball, yellow	3	TKNKT
016 Pantograph / Engine	T-handle	5	TTNTS
017 Main circuit breaker / Power	Standard	3	TKNKT
024 Train lighting	Standard	3	TKNKT
025 Sanding	Ball, black	3	TKNKT
026 Release brake	Standard	3	TKNKT
027 External front lights	Standard	5	SSNSS
028 Instrument lighting	Standard	3	SKNKS
029 Task & driver's cab lighting	Standard	5	STNKT
038 External warning horn	Cylinder	3	TKNKT

Ordering code K series **Handle styles**

Example: **K-SKNKT 3GR CC LB SK G P S**

Series	K	Toggle switch K
Switch function*1	5 letters	Identification: 1 letter per handle position, Sequence: +32°, +16°, 0°, -16°, -32°
	N	Notched centre position
	S	Maintained: Notched position of handle
	T	Momentary: Spring return to next position / neutral position
	K	No maintained or momentary action, position is left out
	<none>	Position blocked*2
Contact positions*3	1 ... 9, A ... Y	1 letter or number per switching element*4 in ascending order 8 letters or numbers for 8 switching elements max.*5
Wiring	CC CO	Push-in connection, cage clamp terminals 2x 12-pole plug connector, screwable
Illumination	<none> LY/LR/LB/LG/LW LYH/LRH/LBH/LGH/LWH LBY/LWY/LGR/LBG	No illumination (standard) Illumination single colour, 24 VDC, yellow / red / blue / green / white Illumination single colour, 110 VDC, white Illumination bicolour *6, 24 VDC blue-yellow / white-yellow / green-red / blue-green
Handle styles	<none> SH SK SKY SW SM	Handle, straight (standard) Special handle Special handle, ball, black Special handle, ball, yellow Special handle, T-handle, black Special handle, cylinder short, black
Contact material	<none> G	Silver contacts (standard) Gold contacts
Sealing	<none> P	No extras (standard) Lead wire seal*7
Mounting method	<none> S	Bushing mount - plus toggle latches (standard) Bushing mount - plus screwing device

Accessories

12 pole Connector wiring CO only

- 1-1733-355020 Plug screwable
- 1-1733-355029 Plug with safety clip

Central fixing with screw device

- 1-1733-337107 Central fixing with screw device

Schaltbau seal wire holder

- 1-1733-303541 Seal wire holder

Toggle latches

- 1-1733-355104 2 pieces toggle latches

Handle styles (retrofit kits)

- 1-1733-354143 Ball, black (special handle SK)
- 1-1733-354152 Ball, yellow (special handle SKY)
- 1-1733-354153 T-handle, black (special handle SW)
- 1-1733-354154 Cylinder handle short, black (special handle SM)

*1 **Switch function:** 5 switch settings max.

*2 **Blocked position:** Handle is mechanically blocked when pushed up or down.

*3 **Contact position:** Letter or number for identification of contact position of each switching element, see table on page 4.

*4 **Switching elements:** K series toggle switches come with S880 series snap-action switches. For details refer to catalogue D80.en or www.schaltbau.com

*5 **Number of switching elements:** 8 max. (with illumination 7 max.)
The contact position of each switching element is identified by 1 letter or number

*6 **Illumination bicolour:** Available only for connection type CO

*7 **Lead wire seal** Only applicable to 3 and 5 position contact assemblies with blocked positions on one side.



Standard handle



Special handle (SH)



Ball handle, yellow (SKY)



T-handle (SW)



Cylinder handle (SM)

i Only stock items are presented in this catalogue which can be supplied in short delivery time. For some variants minimum order quantities apply. Please ask for conditions.

i If you need a special variant, do not hesitate to contact us. Maybe the type of toggle switch assembly you are looking for is among our many special designs. If not, we can also supply customized designs. In this case, however, minimum order quantities apply.

Specifications

K series

Toggle switch	Standard	K series
Switch settings		Configurable at -32° / -16° / 0° / +16° / +32°
Action		Momentary / maintained / blocked
Switching elements		8 x S880 Series snap-action switches max. (Specifications, see catalogue D80)
Conventional thermal current I _{th}		3 A
Minimum current rating		Silver: 5 mA Gold: 1 mA
Nominal voltage Switching elements Lighting Backlit illumination	U _n / U _{n max.} @ 10 s max. U _{bel max.}	24 V or 110 V 24 V / 32 V (single or double colour) or 110 V / 135 V (single colour) 16 V @ U _n 24 V or 72 V @ U _n 110 V
Utilization category		DC-13, 24 V / 2 A
Overtoltage category		OV2
Wiring		CC: Push-in connection, cage clamp terminals CO: 1x or 2x 12 pole connectors
Ingress protection rating	IEC 60529	IP40 below mounting plate IP50 above
Vibration resistance	IEC 61373 IEC 60068	5 ... 20 Hz: 0.0193 g/Hz 20 ... 150 Hz: 7.9 m/s ²
Shock resistance	IEC 61373 IEC 60068	5 g / 22 ms, half sinus
Mechanical endurance		2,000,000 operations
Mounting style		Bushing mount, panel hole Ø 30.5 mm Thickness of desk plate 2 ... 9 mm
Dimensions, from lower edge of bayonet ring, see also dimension diagram (L x W x D)		CC: 68 x 37 x 77.5 mm CO: 80.3 x 37 x 73 mm
Ambient temperature T _a		-40°C ... +85°C
Weight		approx. 150 g , depending on the version

 **SCHALTBAU**

Contact positions

K series

Configuration:

Whenever two or more switching elements are used, they are arranged in order of ascending index numbers or letters, e. g. for a toggle switch assembly with 3 switching elements: 3GR, see table from left to right. This sequence becomes an integral part of the ordering code.





Contact positions:

All available contact positions of the respective switching element within the working range of the toggle switch assembly are delineated by an index number and letter respectively, as shown below.

The switch state symbols as shown in the tables below always refer to the state of the positively driven NC contact.

Switch state:

The contact configuration of the S880 Series V4 package snap-action switches with positive opening operation is SPDT.

Symbol	Switching element
	
	

The state of the switching element is represented by the two symbols, see table below.

Contact positions: Switching states of the NC contact for each switching element (S880 Series snap-action switch)

3 position contact assembly		1	4	F	G	H	Y																									
5 position contact assembly		1	2	3	4	5	6	7	8	9	A	B	C	D	E	F	G	H	K	L	M	N	O	P	R	S	T	U	W	X	Y	
Handle position	Up	+32°																														
		+16°																														
	Down	Centre 0°																														
		-16°																														
		-32°																														

Subject to change

Dimension diagram, Handle styles

K series

• Dimension diagram standard handle, wiring CC

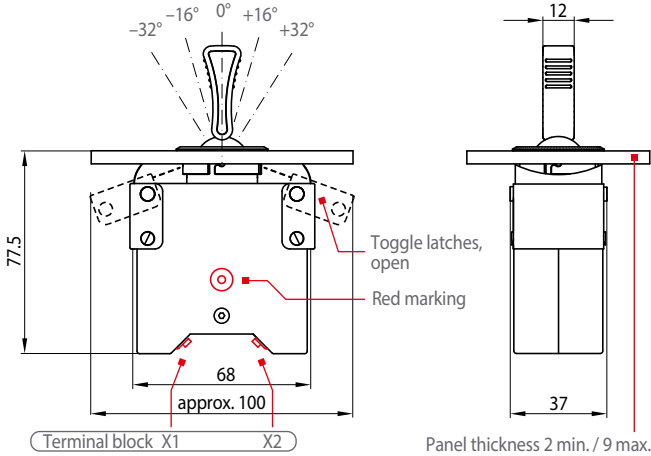

• Dimension diagram standard handle, wiring CO

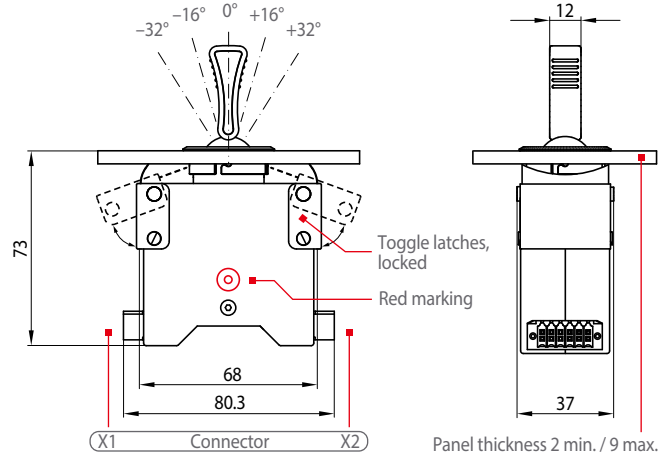

• Handle styles

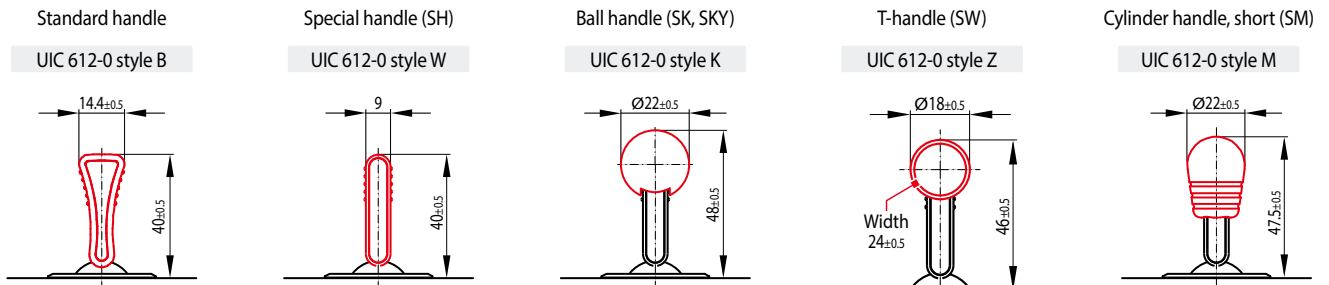

Switch function

K series

The index defines the switch function of the handle positions and is a significant part of the ordering code.
Note: Neutral means Centre 0°.

Index	Switch function	Description	Up	Down
N	Neutral	Notched centre position		
S	Maintained	Notched position		
T	Momentary	Spring return to next position / neutral position (centre 0°)		
K	---	No maintained or momentary action, position is left out		
<none>	Blocked	No action at blocked position		

3 position contact assembly

Index	Handle position				
	Up +32°	Up +16°	Centre 0°	Down -16°	Down -32°
SKNKS	Maintained	---	Neutral	---	Maintained
SKNKT	Maintained	---	Neutral	---	Momentary
TKNKS	Momentary	---	Neutral	---	Maintained
TKNKT	Momentary	---	Neutral	---	Momentary

3 position contact assembly, one side blocked

Index	Handle position				
	Up +32°	Up +16°	Centre 0°	Down -16°	Down -32°
SKN	Maintained	---	Neutral	Blocked	Blocked
TKN	Momentary	---	Neutral	Blocked	Blocked
NKS	Blocked	Blocked	Neutral	---	Maintained
NKT	Blocked	Blocked	Neutral	---	Momentary
SKS	Blocked	Maintained	---	Maintained	Blocked

5 position contact assembly

Index	Handle position				
	Up +32°	Up +16°	Centre 0°	Down -16°	Down -32°
SSNSS	Maintained	Maintained	Neutral	Maintained	Maintained
SSNST	Maintained	Maintained	Neutral	Maintained	Momentary
SSNTS	Maintained	Maintained	Neutral	Momentary	Maintained
STNTT	Maintained	Momentary	Neutral	Momentary	Momentary
STNSS	Maintained	Momentary	Neutral	Maintained	Maintained
STNST	Maintained	Momentary	Neutral	Maintained	Momentary
STNTS	Maintained	Momentary	Neutral	Momentary	Maintained
STNTT	Maintained	Momentary	Neutral	Momentary	Momentary
TSNSS	Momentary	Maintained	Neutral	Maintained	Maintained
TSNST	Momentary	Maintained	Neutral	Maintained	Momentary
TSNTS	Momentary	Maintained	Neutral	Momentary	Maintained
TSNTT	Momentary	Maintained	Neutral	Momentary	Momentary
TTNSS	Momentary	Momentary	Neutral	Maintained	Maintained
TTNST	Momentary	Momentary	Neutral	Maintained	Momentary
TTNTS	Momentary	Momentary	Neutral	Momentary	Maintained
TTNTT	Momentary	Momentary	Neutral	Momentary	Momentary

5 position contact assembly, one side blocked

Index	Handle position				
	Up +32°	Up +16°	Centre 0°	Down -16°	Down -32°
STN	Maintained	Momentary	Neutral	Blocked	Blocked
SSN	Maintained	Maintained	Neutral	Blocked	Blocked
TTN	Momentary	Momentary	Neutral	Blocked	Blocked
TSN	Momentary	Maintained	Neutral	Blocked	Blocked
NST	Blocked	Blocked	Neutral	Maintained	Momentary
NSS	Blocked	Blocked	Neutral	Maintained	Maintained
NTT	Blocked	Blocked	Neutral	Momentary	Momentary
NTS	Blocked	Blocked	Neutral	Momentary	Maintained

Switching elements, LED illumination Contact assignment

K series

Number of: K Series toggle switch assemblies can be fitted with 8 snap-action switches max. If you want to order an LED illuminated toggle switch, please note that the maximum number of switching elements is then reduced to 7.

Connection assignment: Depending on their number, switching elements are to be connected to either terminal block X1 or X2. For assemblies with no more than 4 switching elements only terminal block X1 is needed, that is to say that terminal block X2 can be ignored. So make sure not to confuse the terminal blocks:

- Switching elements 1 ... 4: Terminal block/connector X1
- Switching elements 5 ... 8: Terminal block/connector X2

i **Connection assignment of terminal blocks or connectors X1 and X2:**
The assignment of the connections to the contact positions of your desired configuration is printed on the toggle switch. Schaltbau keeps the order of the output contacts. Please ask for the exact connection assignment.

Switching elements:
K Series toggle switch assemblies come fitted with Schaltbau S880 Series SPDT snap-action switches. Responsible for any switching operation is only the positively driven NC contact of the changeover switch. For further information please refer to our catalogue D80.en or visit our website at www.schaltbau.com

LED illumination: One or two-colour LED lighting is optionally available in different colours

- **Singlecolour:**
Yellow/red/blue/green/white – nominal voltage 24 V
Yellow/red/blue/green/white – nominal voltage 110 V
- **Double colour:**
Blue-yellow/white-yellow/green-red/blue-green – nom. voltage 24 V

Benefits:

- The LED illuminated ring makes separate function and indication lights superfluous, thus saving space in the confined driver's cab as well as the costs of additional equipment.
- Illumination is dimmable by way of PWM or voltage controller.
- Dimmed and consistent backlit illumination enables effective night design.
- Externally brought out connections for the greatest possible flexibility in control.

i **Connection of LED illumination:**
Wiring CC: The wiring is done via terminals 7 and 8. Depending on the number of switching elements fitted to the toggle switch make sure to differentiate between connector X1 or X2. Please ask for the exact connection assignment.

Wiring CO: The wiring is done at X1 via contacts 10, 11 and 12 or at X2 via contacts 1, 2 and 3. For versions with single colour illumination, contacts 10 at X1 or 3 at X2 are not wired. Please ask for the exact contact assignment for your desired configuration.

• **Switching elements, wiring CC**

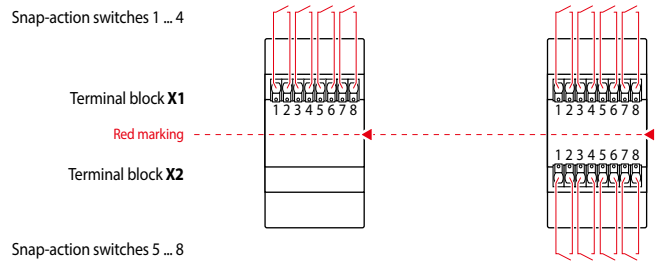

• **Switching elements, wiring CO**

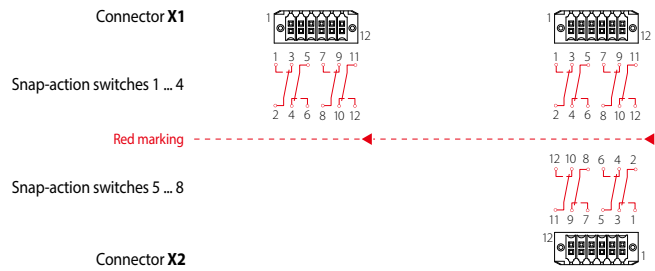

• **Switching elements and LED illumination, wiring CC**

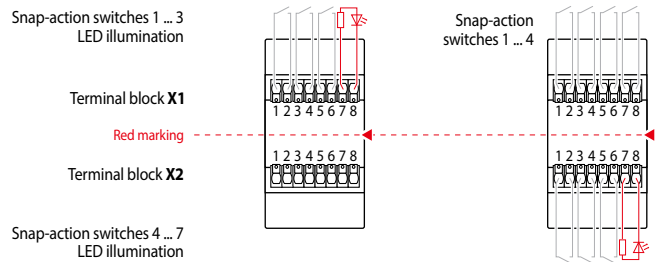

• **Switching elements and LED illumination, wiring CO**

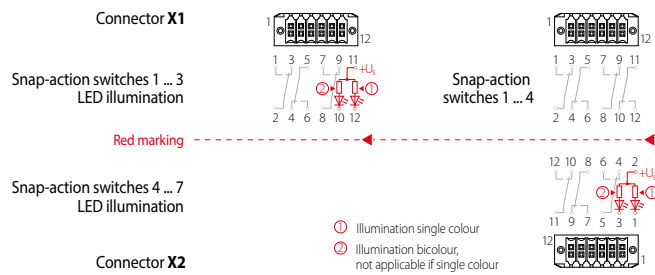

Standards K toggle switches following applicable standards, such as

K series

K toggle switches following applicable standards, such as:

- NF F 16-101:** Railway Rolling Stock, Fire Behaviour, Choice of Materials
- NF F 16-102:** Railway Rolling Stock, Fire Behaviour, Choice of Materials, Application to Electrical Equipment
- DIN 5510-2:** Preventive fire protection in railway vehicles – Part 2: Fire behaviour and fire side effects of materials and parts – Classification, requirements and test methods
- CEN/TS 45545-2:** Railway applications – Fire protection on railway vehicles – Part 2: Requirements for fire behaviour of materials and components
- UIC 612:** Driver machine interfaces for EMU/DMU, locomotives and driving coaches – Functional and system requirements associated with harmonised driver machine interfaces
- EN 50155:** Railway applications – Electronic equipment used on rolling stock

- EN 50124-1:** Railway applications – Insulation coordination – Part 1: Basic requirements – Clearances and creepage distances for all electrical and electronic equipment
- IEC 60068-2-1:** Environmental testing – Part 2-1: Tests – Test A: Cold
- IEC 60068-2-2:** Environmental testing – Part 2-2: Tests – Test B: Dry heat
- IEC 60068-2-38:** Environmental testing – Part 2-38: Tests – Test Z/AD: Composite temperature/humidity cyclic test
- IEC 60529:** Degree of protection provided by enclosures (IP-Code)
- IEC 61373:** Railway applications – Rolling stock equipment – Shock and vibration tests
- DIN EN 16186-2:** Railway applications - Driver's cab - Part 2: Integration of displays, controls and indicators

Lead wire seal Special variant boring for seal wire and holder

K series

Toggle switches should be provided with a lead wire seal for additional security to prevent unauthorized or accidental operation or to make visible that the switch had been activated in some kind of an override operation.

Boring for seal wire. Option «P», s. a. Ordering key.

An additional hole in the lever allows the inclusion of the seal wire.

The seal wire holder must be ordered separately, s. a. ordering key.

Alternatively, a crosshole slotted screw according to DIN 404 can also be used.

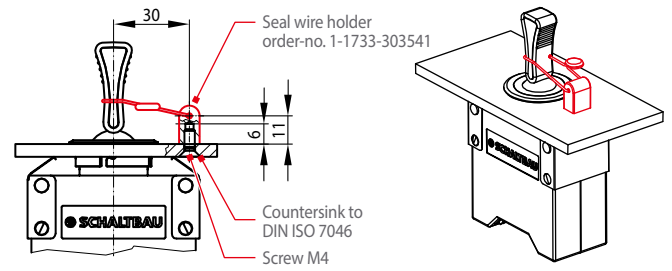

i **Mounting:** The seal wire holder is mounted on the back of the front panel with a countersunk screw, see opposite figure.

i **Usage:** The lead wire seal can only be used with 3 and 5 position contact assemblies with blocked upside or downside positions.

Mounting instructions

K series

Central fixing with toggle latches (no special tools required), standard
Item number: 1-2733-337377

1. Bring toggle latches into mounting position and keep them open.
2. Push toggle and bushing of the switch through hole in front plate.
3. Place bayonet lock ring on top of the switch and lock tight.
4. Pre-tension toggle latches by approx. 45° (4a), align switch, for final fixing swivel quick release fasteners approx. 45° further until they engage (4b).
5. Wiring:
CC: Insert the individual conductors into the terminal strips, see also paragraph wiring below.
CO: Plug in and lock the assembled connectors X1 and X2

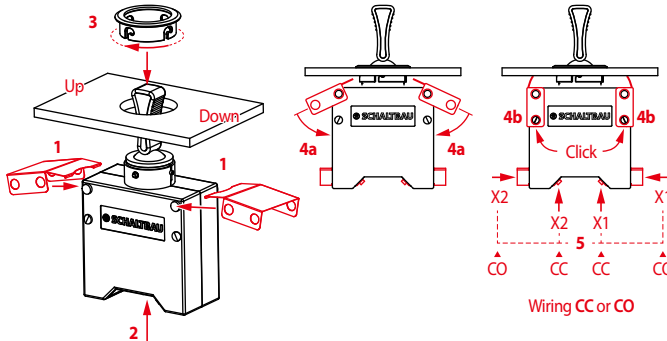

i **Mounting:** No special tools are required here. Push both toggle latches firmly home until they are clipped in position. Assembly may only be carried out by qualified personnel!

Dismounting: For prying open the toggle latches a simple screwdriver will do the job.

Central fixing with screw device, optional
Item number: 1-1733-337107

1. Place screwing device on top of toggle switch.
2. Push toggle and bushing of the switch through hole in front plate.
3. Place bayonet lock ring on top of the switch and lock tight.
4. Align switch (4a), press brackets of screwing device into underside of front plate by tightening both screws (4b).
5. Wiring:
CC: Insert the individual conductors into the terminal strips, see also paragraph wiring below.
CO: Plug in and lock the assembled connectors X1 and X2

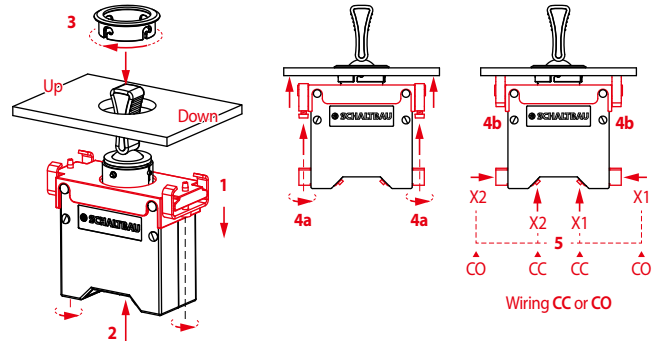

Wiring, CC only:

Depending on the number of switching elements, K Series toggle switches come with either 1 or 2 terminal blocks X1 and X2. Unlike cage clamps the wire need not be screwed to the terminal but can directly be pushed in to it.

- Be sure to use the right size wire connector. For correct wire gauges refer to the table »Terminal block X1, X2« below.
- If wire end ferrules are used, max. two stranded wires can be connected per contact. Twin wire-end ferrules must be used for this purpose (IEC 60999-1).
- K Series toggle switches have a fully insulated plastic casing. A separate ground connection is, therefore, not necessary.

Terminal block X1, X2 Terminal style	Wire gauges (AWG)	
	Min.	Max.
Wire or lead, stripped 1 cm	24	15
Ferrule to DIN 46228/1	23	15
Ferrule to DIN 46228/4	23	18

Subject to change / Dimensions in mm

Panel cutout:

- The size of the mounting hole is Ø 30.5 mm, the same as for most push-button switches installed in drivers' cabs.
- The illustration below shows the UIC-compliant mounting grid. The minimum distances must be observed!

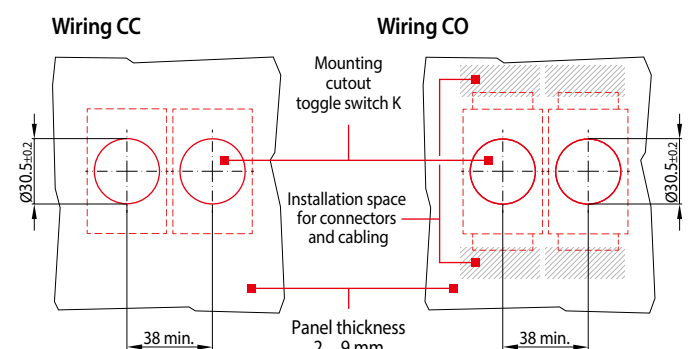

Schaltbau GmbH

For detailed information on our products and services visit our website – or give us a call!

Schaltbau GmbH
Hollerithstrasse 5
81829 Munich
Germany



Phone +49 89 9 30 05-0
Fax +49 89 9 30 05-350
Internet www.schaltbau.com
e-Mail contact@schaltbau.de

with compliments:



The production facilities of Schaltbau GmbH have been IRIS certified since 2008.



Certified to DIN EN ISO 14001 since 2002. For the most recent certificate visit our website.



Certified to DIN EN ISO 9001 since 1994. For the most recent certificate visit our website.

Electrical Components and Systems for Railway Engineering and Industrial Applications

Connectors

- Connectors manufactured to industry standards
- Connectors to suit the special requirements of communications engineering (MIL connectors)
- Charging connectors for battery-powered machines and systems
- Connectors for railway engineering, including UIC connectors
- Special connectors to suit customer requirements

Snap-action switches

- Snap-action switches with positive opening operation
- Snap-action switches with self-cleaning contacts
- Snap-action switch made of robust polyetherimide (PEI)
- Snap-action switch with two galvanically isolated contact bridges
- Special switches to suit customer requirements

Contactors Emergency disconnect switches

- Single and multi-pole DC contactors
- High-voltage AC/DC contactors
- Contactors for battery powered vehicles and power supplies
- Contactors for railway applications
- Terminal bolts and fuse holders
- DC emergency disconnect switches
- Special contactors to suit customer requirements

Electrics for rolling stock

- Equipment for driver's cab
- Equipment for passenger use
- High-voltage switchgear
- High-voltage heaters
- High-voltage roof equipment
- Equipment for electric brakes
- Design and engineering of train electrics to customer requirements