

1

Connectors

UIC Series

**Inter-car jumpers
to UIC 558 VE**

**Installation and maintenance
instructions**

Manual F120.en

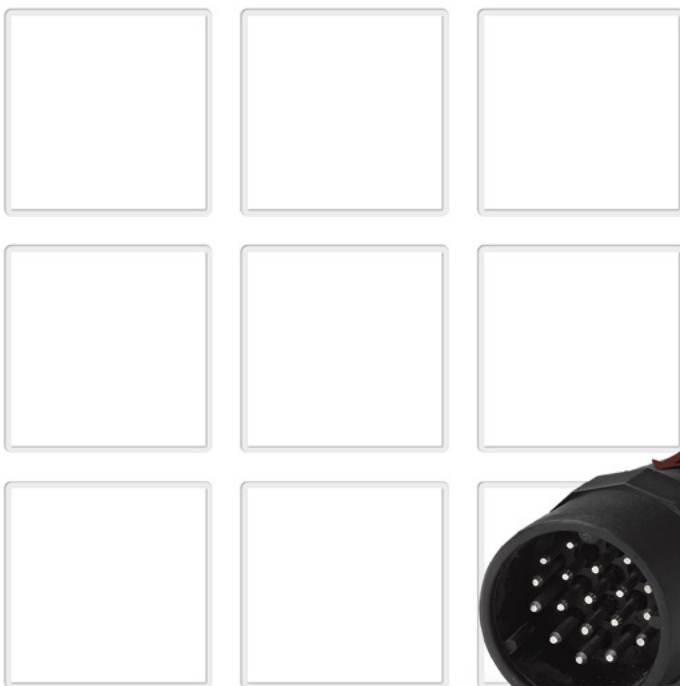

Inhalt

1. Important Basic Information	3
1.1 Legal Notes.....	3
1.2 Conventions for this Installation and Maintenance Instructions.....	3
2. General and Security Information	3
2.1 Observing the Instructions.....	3
2.2 User Obligations	3
2.3 Intended Use.....	4
2.4 Ambient Conditions.....	4
3. Dangers and Security Measures	5
3.1 Electrical Dangers	5
3.2 Other Dangers.....	5
3.3 Mechanical Dangers.....	6
3.4 Measures for Avoiding Damages.....	6
3.5 Measures for Avoiding Malfunctions	7
4. Description.....	7
4.1 Details.....	7
4.2 Design	8
4.3 Survey of the Components (Preferred Types)	9
5. Installation	12
5.1 Check Parts for Transport Damage	12
5.2 Dimensions/Interfaces to the Vehicle.....	12
5.3 Installing Coupling Receptacles	12
5.4 Coupling Receptacles with Socket Insert and Assembled Connector Cable.....	13
5.5 Coupling Receptacles with Replacement Insert, Crimp Adapter and Assembled Connector Cable.....	14
5.6 Disassembly of Replacement Insert and Crimp Adapter	15
5.7 Installing the Dummy Receptacle.....	16
5.8 Installing Wall-mount Cable Glands for Cable Plugs with Connector Cable.....	16
5.9 Storage of Connector Cables	17
6. Plugging Procedure.....	18
6.1 Plugging	20
6.2 Unplugging	20
7. Maintenance	21
7.1 Intervals for Checks and Maintenance	21
7.2 Visual and Functional Inspection at each Plugging	21
7.3 Visual and Functional Inspection/Maintenance of Coupling Receptacle and Dummy Receptacle.....	21
7.4 Visual and Functional Inspection/Maintenance of the Cable Plug	23
8. Special Tools	23
9. Spare Parts	24
10. Technical Data	25

1. Important Basic Information

1.1 Legal Notes

Without prior written consent of Schaltbau GmbH, the instructions is not allowed to be electronically or mechanically reproduced – as a whole or in parts – be distributed, changed, transmitted, translated into another language or used in any other way.

Schaltbau GmbH cannot be held liable for damage caused by not observing (or only partly observing) the Installation and installation instructions.

1.2 Conventions for this Installation and Maintenance Instructions

This instructions describe the installation and maintenance of the connectors.

Cross references are presented in **bold italics**.

To highlight particularly important safety instructions and other information, the following symbols are used in this instructions:

DANGER

Indicates a hazardous situation with a high level of risk which, if not avoided, will result in death or serious injury.

WARNING

Indicates a hazardous situation with a medium level of risk which, if not avoided, could result in death or serious injury.

CAUTION

Indicates a hazardous situation with a low level of risk which, if not avoided, may result in minor or moderate injury.

NOTICE

Indicates a hazardous situation which, if not avoided, may result in property damage, such as service interruption or damage to equipment or other materials.



Refers to technical features and methods aimed at facilitating work or to particularly important information.

2. General and Security Information

The connectors dealt with in this document are intended for use with low-voltage systems for special installations. They are designed and tested in compliance with the generally recognised state of the art. However, improper use, operation, handling, maintenance of or tampering with electric equipment can cause serious or fatal injury to the user or others, and the appliance or other property can be damaged.

The operation, maintenance and installation instructions for the connectors must therefore be strictly followed.

Any uncertainties must be clarified and all queries must include details of the type of device and the serial number.

Only authorized and trained personnel are allowed to plan and carry out all mechanical and electrical installations, transport, commissioning, as well as maintenance and repair work. This applies to the observation of the general installation and safety regulations for low-voltage systems as well as the proper use of tools approved for this purpose.

Electrical devices are to be protected, as much as possible, from dust and moisture during installation or storage.

2.1 Observing the Instructions

- ▶ All staff must read and understand the instructions and adhere to them when working with the device.
- ▶ **Always carefully observe all safety warnings!**

2.2 User Obligations

- ▶ Observe the respective national instructions and other applicable safety regulations for the use and cable assembly of connectors and connector systems.
- ▶ Observe all applicable national provisions, all safety, accident prevention and environmental regulations as well as the recognized technical rules for safe and proper working.
- ▶ Carry out regular inspections of all protection and safety devices to see if they work properly.
- ▶ Work on electric equipment may only be performed by a qualified electrician or trained personnel working under the direction and supervision of a qualified electrician according to the applicable rules of electrical engineering.

- ▶ A qualified electrician is a person who can judge and recognise the possible dangers of the jobs commended to him based on his training, knowledge and experience and by knowledge of the appropriate regulations.
- ▶ Staff must be informed clearly about who is responsible for the maintenance of the connectors.

2.3 Intended Use

- ▶ The connectors are intended for plug-in and detachable connections of components, devices and systems only. They are used for the transmission of power and signals.
- ▶ In order to comply with DIN EN IEC 61984 make sure that always the live side of the connector is fitted with socket contacts.
- ▶ Crimp connections have to be manufactured according to DIN EN IEC 60352-2 – Solderless Connections.
- ▶ Make sure that there are no undue tensile, pressure, flexing and torsion loads on the connection cable.
- ▶ None of the operating conditions defined in our catalogue **F120.en** in section **"Specifications"**, such as voltages, currents, ambient conditions, etc. may be changed.
- ▶ Work on the connectors must only be carried out by staff who meets the requirements set out in these instructions.
- ▶ According to DIN EN IEC 61984 connectors used as intended must not be engaged or disengaged when live or under load.
- ▶ The connectors must not be contaminated with aggressive media.
- ▶ A connector that does not engage easily requires special attention:
Check for the correct orientation, pollution or if contacts got bent. Remedy the cause without delay. Never use force! The connector should always engage easily.
- ▶ In order to meet the requirements of the protection class and to protect the connectors against the entry of dirt or moisture, make sure that when not mated,
 - the plug is always inserted into a dummy receptacle
 - the hinged lid of receptacles is closed, according to its intended use.
- ▶ The connector cables have to be stored / kept properly in the vehicle.

- ▶ When disengaging a connector, pull the plug and never the cable.
- ▶ Open the hinged lid of the receptacle by an angle of at least 110° but not more than 130°. An overstretching of the hinged lid may shorten the operational life span of the torsion spring and may damage the hinge mechanism.
- ▶ Always close the hinged lid by hand, don't let it slam.
- ▶ Use the connector only according to its intended use. Replace or repair damaged parts exclusively with original parts. Any other usage of or tampering with the connector is considered contrary to its intended use. No liability is assumed for damages and accidents caused due to non-compliance with the instructions or improper use of the connector.

2.4 Ambient Conditions

NOTICE

The connectors are constructed for specific ambient conditions.

- ▶ Operate the connectors only under the ambient conditions, like temperature ranges and IP protection classes as defined in our **catalogue F120.en** in section **"Specifications"**.
schaltbau.info/download1en

Note:

In case of a very low or very high ambient temperature which approximates the limits of the allowable operating temperature range specified in our **catalogue F120.en** in section **"Specifications"**,

- a higher effort may be needed for the plugging and unplugging and
- the operational life span of plug and coupling receptacle may thus be reduced due to increased wear and tear.

3. Dangers and Security Measures



3.1 Electrical Dangers

	<p>⚠ DANGER</p>
	<p>The connectors contain components that carry voltage. Risk of electric shock! Always observe the following safety regulations before beginning any work on electrical constructions:</p> <ul style="list-style-type: none"> ▶ Disconnect ▶ Ensure that it is not possible to reconnect unintentionally ▶ Clearly mark your work area ▶ Make sure that there is no voltage present ▶ Earth and short circuit the installation ▶ Insulate or cover adjacent energized parts ▶ Only an electrically skilled person may determine if there is no voltage present

	<p>⚠ WARNING</p>
	<p>Dirt, moisture, snow and ice in the interior of coupling receptacles or dummy receptacles contaminate the plug. The coupling of a contaminated plug to the coupling receptacle may lead to electric shock, short circuit and damage to the connectors!</p> <ul style="list-style-type: none"> ▶ Always check if the interior of the receptacles is free from dirt, moisture, snow and ice before inserting a plug into a coupling receptacle or a dummy receptacle. ▶ Do not insert a plug into a receptacle when the latter is contaminated, moist or contaminated with snow and ice. ▶ Remove dirt, moisture, snow and ice without residues from the interior of receptacles and from the plug. ▶ Never couple a contaminated plug to the coupling receptacle.

3.2 Other Dangers

	<p>⚠ WARNING</p>
	<p>Exclusively use the connectors for purposes as indicated in the specifications and data sheets. A wrong application can cause accidents and severe damages to persons.</p> <ul style="list-style-type: none"> ▶ The manufacturer doesn't take the responsibility for accidents which were caused by improper use of the product. ▶ We recommend the use of fault current safety systems in constructions with voltages higher than safety extra-low voltage.

 	<p>⚠ WARNING</p>
	<p>The plugging and disconnecting of the connectors on-load can cause electric arcs. When explosive substances or ignition sources of any kind are nearby, there is a risk of fire and explosion!</p> <ul style="list-style-type: none"> ▶ Never plug and disconnect the connectors on-load.

	⚠ CAUTION
	<p>The connectors may grow warm during operation and they may become hot depending on the ambient temperature and the conditions of use. Risk of burn to the hands!</p> <ul style="list-style-type: none"> ▶ Wear safety gloves when plugging and disconnecting the connectors in the case of a high ambient temperature.

3.3 Mechanical Dangers

	⚠ CAUTION
	<p>The connectors contain components that are subject to mechanical stress. There is a risk of crushing!</p> <ul style="list-style-type: none"> ▶ Use only appropriate tools for work on the connectors. ▶ Ensure that components, which are subject to mechanical stress, are secured before installing or dismantling these components.

	⚠ CAUTION
	<p>The connectors contain sharp-edged parts. Risk of injury!</p> <ul style="list-style-type: none"> ▶ Use only appropriate tools for maintenance work on the connectors. ▶ Wear protective gloves when working with sharp-edged components.

3.4 Measures for Avoiding Damages

NOTICE
<p>Aggressive fluids may damage the connectors.</p> <ul style="list-style-type: none"> ▶ Make sure that the connectors are not exposed to aggressive fluids.

NOTICE
<p>Improper handling of the connectors, e.g. when hitting the floor with some impact, can result in breakage, bent pin contacts, cracks and deformation.</p> <ul style="list-style-type: none"> ▶ Make sure that the connectors are always used properly. ▶ Regularly sight-check the connectors for potential damages. ▶ Regularly check the connectors for bent or pushed back contacts. ▶ Immediately replace damaged components.

3.5 Measures for Avoiding Malfunctions

NOTICE

In the case of damage, wear and tear and/or soiling of the connector components - in the form of a partial break, sharp edges and discoloured surfaces - the functional safety of the connectors is no longer guaranteed.

- ▶ Carry out regular visual checks to detect wear and tear and dirt.
- ▶ Immediately replace damaged parts.
- ▶ Immediately remove dirt without leaving any residues.
- ▶ Immediately replace parts with stubborn dirt.

NOTICE

Inappropriate handling when plugging or disconnecting may damage the connectors. The functional safety of the connectors is no longer guaranteed when parts are damaged.

- ▶ Make sure that the guideways and slots of plug and receptacle always interlock when plugging!
- ▶ Take care that plug and receptacle do not tilt and that they are plugged without force.
- ▶ Make sure before the plugging procedure that plug and receptacle as well as the hinged lid of the receptacle are not contaminated. Remove any existing dirt.
- ▶ Make sure that when not mated,
 - the plug is always inserted into a dummy receptacle,
 - the hinged lid of receptacles is closed according to its intended use.

4. Description

4.1 Details

Break-away connector

- ▶ If installed as intended, the break-away connector guarantees the non-destructive separation of the plug from the receptacle when two vehicles that are not electrically decoupled move away from each other.

Replacement Insert for receptacles

- ▶ With the 18-pole version in compliance with UIC558, a coupling receptacle is now available which leads to a considerable reduction of the times of maintenance and idleness. In the case of maintenance, you don't have to rewire but only the replacement insert has to be changed. The contact insert can be replaced directly on-site – the lengthy electrical test of contacts and cables is no longer necessary.

Shell

- ▶ quick and easy to install
- ▶ individual components are easy to replace
- ▶ seals can be replaced without disassembling the contacts
- ▶ Same basic design for empty, coupling and dummy receptacle: empty receptacles are converted to coupling or dummy receptacles by fitting the appropriate contact inserts.

Cable Assembly

Connector cables (single and double ended) can be made to customer specifications upon request.

Technical Information and Material Specifications

- ▶ For technical information and material specifications, see our catalogue *catalogue F120.en*. Download at: schaltbau.info/download1en

4.2 Design

Connectors in the UIC 558 series are 13 or 18-pole connectors to loop through different control signals between railway vehicles. The connectors are in compliance with UIC 558. They connect lines used for:

- ▶ remote control of lights
- ▶ remote control of doors
- ▶ public address system in passenger coaches and traction vehicle
- ▶ transmission of binary data

Connectors in the UIC 558 series consist of the following components:

- ▶ Connector cable, single ended, in the desired length with cable plugs, single-sided assembly, or connector cable, double ended, with two cable plugs, double-sided assembly.
- ▶ Receptacle (consisting of empty receptacle + contact insert with assembled connector cable, single ended, in the desired length)
- ▶ Receptacle (consisting of empty receptacle + replacement insert and crimp adapter with assembled connector cable, single ended, in the desired length)
- ▶ Dummy receptacle (consisting of empty receptacle + contact insert unpopulated; for the insertion of a non-coupled cable plug)
- ▶ Full customer-specific cable sets

Contact inserts for 13 and 18 contacts in compliance with UIC 558 as well as 22 contacts + PE for other applications and customer-specific contact arrangements are available.

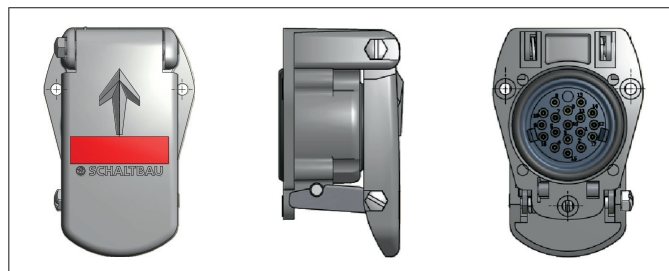

Fig. 1: Receptacle with socket contacts

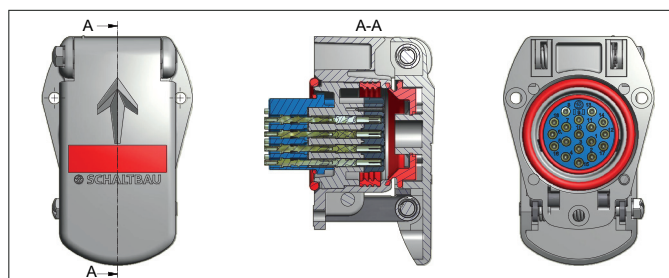

Fig. 2: Receptacle with replacement insert and crimp adapter

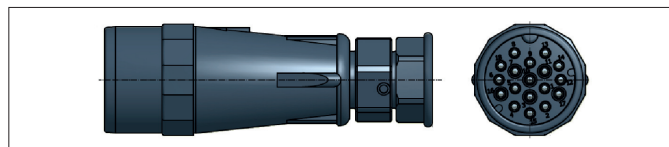
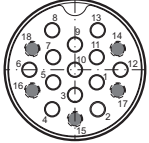
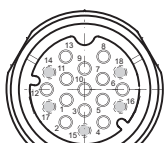
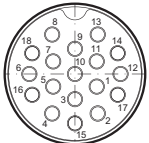
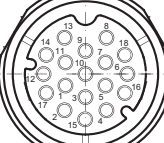
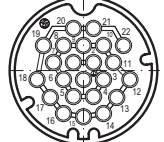



Fig. 3: Plug with pin contacts

UIC 558 contact insert arrangements		
No. of contacts	Pin insert for plugs	Socket insert for receptacles
13	 <p>UIC E-13P Pole 1 -13: Pin type SHC-1,00-X¹⁾-30</p>	 <p>UIC E-13S Pole 1 -13: Socket type BHC-1,00-X¹⁾-30</p>
18	 <p>UIC E-18P Pole 1 -18: Pin type SHC-1,00-X¹⁾-30</p>	 <p>UIC E-18S Pole 1 -18: Socket type BHC-1,00-X¹⁾-30</p>

Non-UIC 558 compliant contact insert arrangements		
No. of contacts	Pin insert for plugs	Socket insert for receptacles
22 + PE	 <p>UIC E-22P + PE Pole 1 - 22: Pin type SHC-1,00-X¹⁾-30 Pole PE: Pin type SHC-1,00-X¹⁾-30</p>	 <p>UIC E-22S + PE Pole 1 - 22: Socket type BHC-1,00-X¹⁾-30 Pole PE: Socket type BHC-1,00-X¹⁾-30</p>

¹⁾ Contact surfaces optionally:

- Ni (nickel), complying with the standard
 - Au (gold)*
 - Ag (silver)*
- * Special design on request

4.3 Survey of the Components (Preferred Types)

Connector cable with plug (single ended)		
No. of contacts	Figure/description (dimensions in mm)	Ordering code
13	<p>Connector cable with cable harness and plug, completely assembled cable set in required length, 13-pole, pin contacts (13-pole plug with less equipped 18 pole cable)</p>	UIC SK 13P E0 Lxxxx ¹⁾
18	<p>Connector cable with plug, completely assembled cable set in required length 18-pole, pin contacts</p>	UIC SL 18P ER Lxxxx ¹⁾

Connector cable with plug (double ended)		
No. of contacts	Figure/description (dimensions in mm)	Ordering code
13 18	<p>Connector cable with 2 plugs, completely assembled cable set in required length, available in 13-pole and 18-pole version, pin contacts (13-pole plug with less equipped 18-pole cable)</p>	13-pole version: UIC VK 13P E0 Lxxxx ¹⁾ 18-pole version: UIC VK 18P ER Lxxxx ¹⁾

13-pole coupling receptacle with socket insert, connector cable and cable harness		
No. of contacts	Figure/description (dimensions in mm)	Ordering code
13	<p>Socket insert with connector cable and cable harness, completely assembled cable set in required length, 13-pole, socket contacts + empty receptacle (13-pole socket insert with less equipped 18-pole cable)</p>	Socket insert with connector cable and cable harness: UIC DK 13S 00 Lxxxx ¹⁾ + Empty receptacle: UIC LD 130 C0 (RAL 7035, light grey)

¹⁾ Cable length Lxxxx in mm: we assemble the required cable length by arrangement

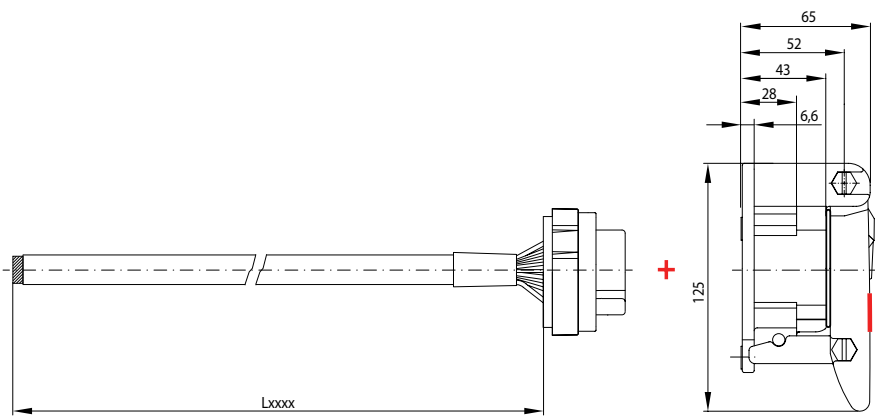
18-pole coupling receptacle with socket insert and connector cable		
No. of contacts	Figure/description (dimensions in mm)	Ordering code
18	 <p>Connector cable with socket insert, completely assembled cable set in required length, 18-pole, socket contacts + empty receptacle</p>	18-pole socket insert with connector cable: UIC DL 18S 00 Lxxxx ¹⁾ + Empty receptacle: UIC LD 180 CR (RAL 7035, light grey, red colour markings)

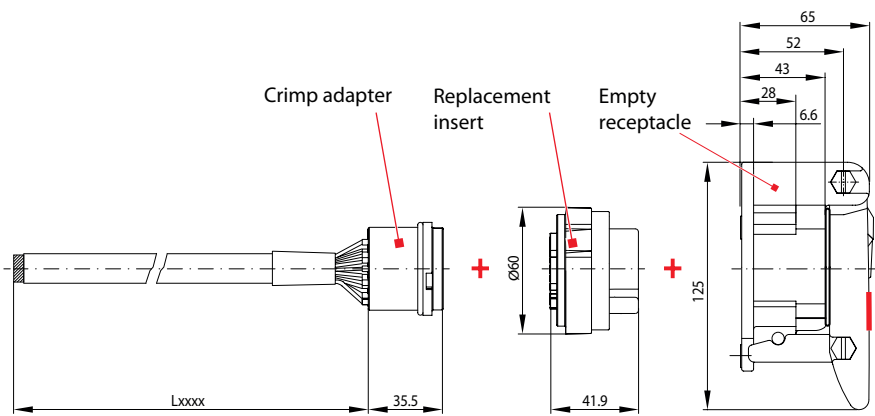
18-pole coupling receptacle with replacement insert, crimp adapter and connector cable		
No. of contacts	Figure/description (dimensions in mm)	Ordering code
18	 <p>Crimp adapter with connector cable, completely assembled cable set in required length, 18-pole, pin contacts + 18-pole replacement insert with socket contacts implemented on both sides + empty receptacle</p>	18-pole crimp adapter with connector cable: UIC CA 18P 00 Lxxxx ¹⁾ + 18-pole replacement insert: UIC BT 18S/P + Empty receptacle: UIC LD 180 CR ZW (RAL 7035, light grey, red colour markings)

¹⁾ Cable length Lxxxx in mm: we assemble the required cable length by arrangement

Coupling receptacle, dummy receptacle, empty receptacle		
No. of contacts	Figure/description (dimensions in mm)	Ordering code
<p>13</p> <p>18</p> <p>22</p>	<p>Coupling receptacle, dummy receptacle</p> <p>Empty receptacle</p> <p>Earthing bolt M6, only special design F4</p> <ul style="list-style-type: none"> - Coupling receptacle with socket insert and crimp contacts (all socket contacts are included in delivery) - Dummy receptacle with socket insert without crimp contacts - Empty receptacle without socket insert without crimp contacts 	<p>Coupling receptacle</p> <ul style="list-style-type: none"> - 13-pole: UIC KD 13S C0 (RAL 7035, light grey) - 18-pole: UIC KD 18S CR (RAL 7035, light grey, red colour markings): - 22-pole: UIC KD 22S CB (RAL 7035, light grey, blue colour markings): <p>Dummy receptacle</p> <ul style="list-style-type: none"> - 13-pole: UIC BD 130 C0 (RAL 7035, light grey) - 18-pole: UIC BD 180 CR (RAL 7035, light grey, red colour markings): - 22-pole: UIC BD 220 CB (RAL 7035, light grey, blue colour markings) <p>Empty receptacle</p> <ul style="list-style-type: none"> - 13-pole: UIC LD 130 C0 (RAL 7035, light grey) - 18-pole: UIC LD 180 CR (RAL 7035, light grey, red colour markings): - 22-pole: UIC LD 220 CB (RAL 7035, light grey, blue colour markings)

Wall-mount cable gland	
Figure/description (dimensions in mm)	Ordering code
<p>Mounting hole</p> <p>Mounting wall</p> <p>Nut PA 6 GF30 black</p> <p>Spring disc</p> <p>Supporting ring</p> <p>Strain relief bushing PA 6 GF30, black</p> <p>Tensioning screw PA 6 GF30 black</p> <p>Ø 30</p> <p>Pg 21</p> <p>36</p> <p>0 ... 8</p> <p>24</p> <p>39.5+1</p> <p>D2</p> <p>Cable gland PG21 with antikink fitting</p>	<p>Cable glands PG21 with antikink fitting</p> <p>UIC KK D2</p> <p>cable diameter 16.5 ... 18.5 mm</p>

5. Installation

	⚠ DANGER
	<p>The connectors contain components that carry voltage. Risk of electric shock! Always observe the following safety regulations before beginning any work on electrical constructions:</p> <ul style="list-style-type: none"> ▶ Disconnect ▶ Ensure that it is not possible to re-connect unintentionally ▶ Clearly mark your work area ▶ Make sure that there is no voltage present ▶ Earth and short circuit the installation ▶ Insulate or cover adjacent energized parts ▶ Only an electrically skilled person may determine if there is no voltage present

NOTICE
<p>During installation, ensure that dirt caused by surrounding construction activities does not get into the connectors.</p>

5.1 Check Parts for Transport Damage

NOTICE
<p>If parts are damaged, the functional reliability of the connectors is no longer given.</p> <ul style="list-style-type: none"> ▶ Before installing, check all parts for any possible transport damage. ▶ Do not install any damaged parts.

5.2 Dimensions/Interfaces to the Vehicle

The dimensions to the interfaces of the vehicle are given in the respective data sheets or in our catalogue **F120.en**.
 (Download: schaltbau.info/download1en)

5.3 Installing Coupling Receptacles

Preliminaries

The assembly has to be carried out by qualified trained personnel.

Correct mounting position

The break-away connector function guarantees a non-destructive separation of plug and receptacle when two electrically not uncoupled vehicles move away from each other. For this purpose, the mounting position of the coupling receptacle must be performed in compliance with UIC 558 VE in order to guarantee the prescribed tensile forces / directions on the flexible cable. **Fig. 4/D** shows an example: Vertical mounting position, lid opening to the top.

Moreover, a mounting position up to an angle of max. 90° clockwise is possible for coupling receptacles. In this instance, the lid must show downward (for examples refer to **Fig. 4/E and F**).

NOTICE
<p>An installation of the coupling receptacle with lid showing upward (refer to Fig. 4/G) is not permissible! When the lid is open in this mounting position, contamination and moisture might penetrate the contacts and accumulate there during the plugging procedure or in the plugged condition. Moreover, this mounting position causes a not definable limitation of the prescribed tensile forces / directions on the flexible cable and thus on the contact retainer and locking mechanism. In this mounting position, the plug connection is strained in transverse direction and the cable causes a unilateral strain on shell, contacts and locking mechanism!</p>

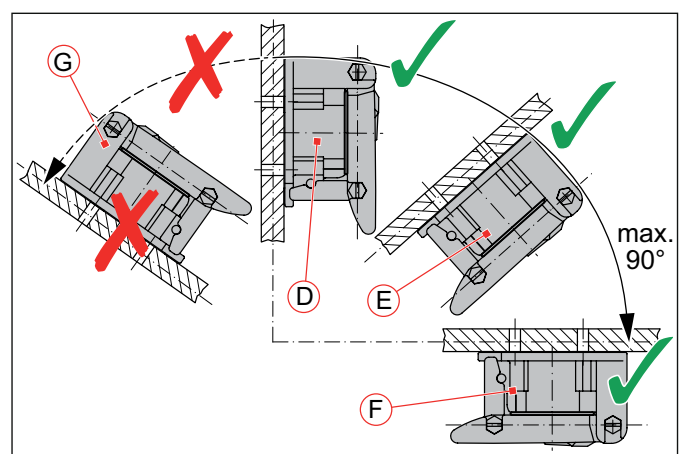

Fig. 4: Permissible and not permissible mounting positions for receptacles

Requirements to the vehicle wall / mounting surface

The surface of the vehicle wall / mounting surface must show an average surface roughness Rz of 6.3 ... 12.5 µm. The tightening torque for the fastening screws is 10.5 Nm, for screws of steel with strength class 8.8.

Mounting points

The coupling receptacle is fastened with 3 cylinder screws M6 or alternatively with 4 cylinder screws M6.

The tightening torque (10.5 Nm for screws of steel with strength class 8.8) and the length of the fastening screws must be determined by the manufacturer of the vehicles depending on the structural conditions.

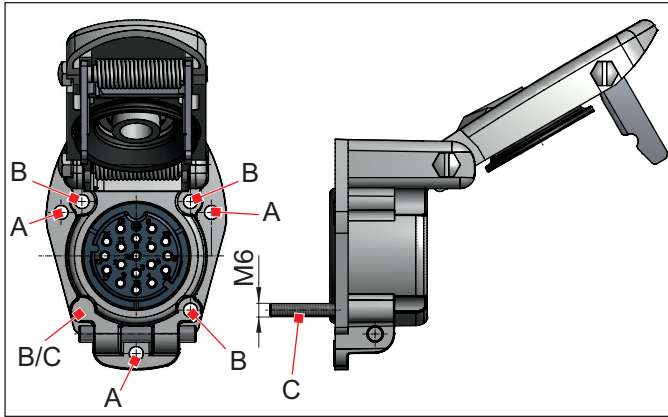

Fig. 5: Mounting points of receptacle

- A Mounting points for installation with 3 holes
- B Mounting points for installation with 4 holes
- C Earthing bolt M6 (only special design F4)

The dimensions and arrangement of the mounting holes are shown in Figures 6 and 7.

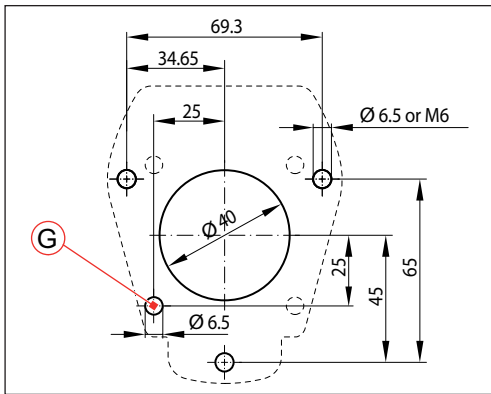

Fig. 6: 3-hole mounting, G = hole for M6 earthing bolt M6 (only for receptacle with special design F4)

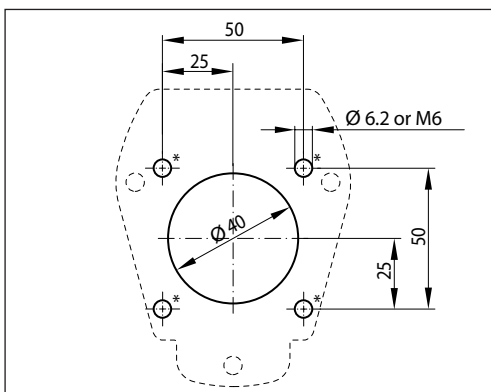

Fig. 7: 4-hole mounting

* Diameter for all fixing and securing elements, such as screw heads: 12.5 mm max.

Two possibilities of installation are available for coupling receptacles:

- Installation with socket insert and completely assembled connector cable (13-, 18-pole)
- Installation with a replacement insert and completely assembled crimp adapter (18-pole)

5.4 Coupling Receptacles with Socket Insert and Assembled Connector Cable

- ▶ Thread the O-ring (3) onto the open end of the connector cable (1).
- ▶ Pull the open end of the connector cable (1) through the prepared mounting hole (max. 40 mm diameter) in the vehicle wall (2).

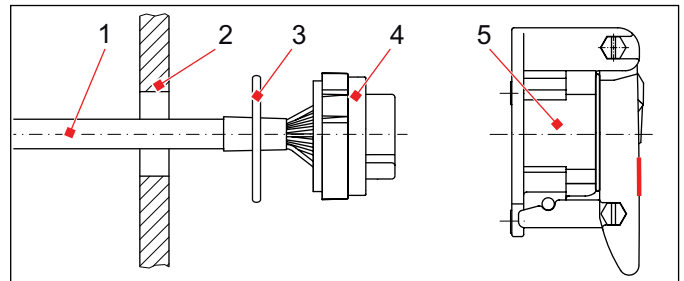

Fig. 8: Coupling receptacle with assembled socket insert and connector cable

- 1 Connector cable, completely assembled
- 2 Vehicle wall with prepared mounting holes
- 3 O-ring for socket insert
- 4 Socket insert, completely assembled
- 5 Empty receptacle with inserted rubber seal (lamella ring)

- ▶ Slide the assembled socket insert (4) in the specified coding position with the slots (A) onto the lateral guideways (B) of the coupling receptacle (5).

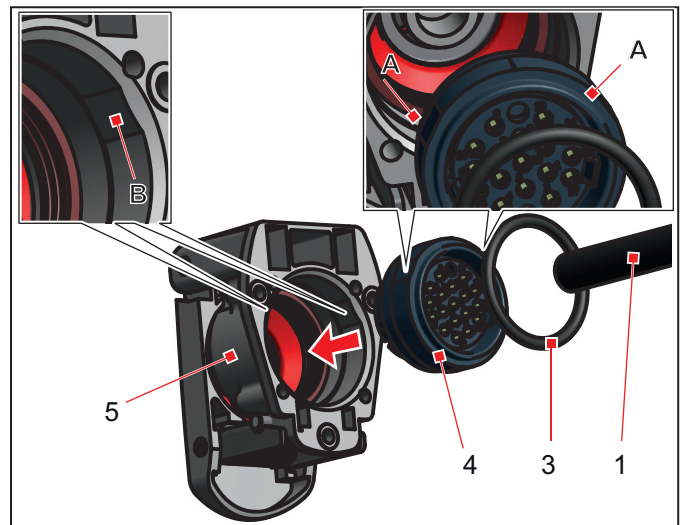

Fig. 9: Coding position with slots (A) on the socket insert and guideways (B) in the coupling receptacle

NOTICE

To ensure the proper operation, the socket insert and the contacts may not be under tension.

- ▶ Make sure that the specified bending radius is observed when laying the cables: $8 \times \text{cable diameter} = 145 \text{ mm}$
- ▶ Slightly fasten the receptacle (5) with the three M6 cylinder screws (or alternatively with four M6 cylinder screws) to the vehicle wall (2).
- ▶ Check if the O-ring (3) of the socket insert and rubber seal (lamella ring) (6) are properly in place. Align seals where applicable.
- ▶ Adjust all of the parts and fasten the M6 cylinder screws. Tightening torque: 10.5 Nm for screws of steel with strength class 8.8.

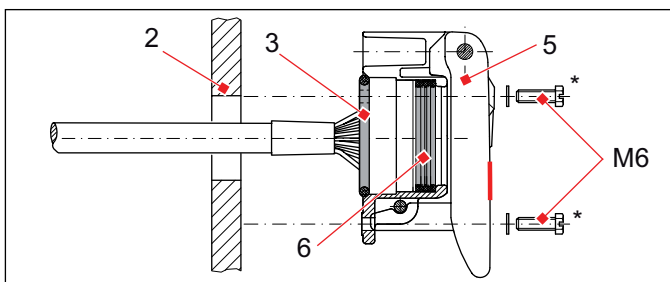

Fig. 10: Screw coupling receptacle with socket insert to the vehicle wall

* Diameter for all fixing and securing elements, such as screw heads: 12.5 mm max.

Test

- ▶ Check that all of the installed parts are in the correct position and function properly.
- ▶ Make sure that there are no undue tensile, pressure, flexing and torsion loads on the connection cables.
- ▶ Check the functionality of the receptacle lid.

Commissioning

DANGER

In the case of a contact of the traction current line with the vehicle, the coupling receptacle may be highly energised. Deadly hazard!

- ▶ Before commissioning the receptacle, a high voltage test must be carried out.

- ▶ Before commissioning the receptacle, it must be tested in accordance with EN 50215.

5.5 Coupling Receptacles with Replacement Insert, Crimp Adapter and Assembled Connector Cable

- ▶ Thread the O-ring (7) onto the open end of the connector cable (1) and slide it onto the crimp adapter (8).
- ▶ Pull the open end of the connector cable (1) through the prepared mounting hole (max. 40 mm diameter) in the vehicle wall (2).
- ▶ Attach the O-ring (3) to the replacement insert (9).

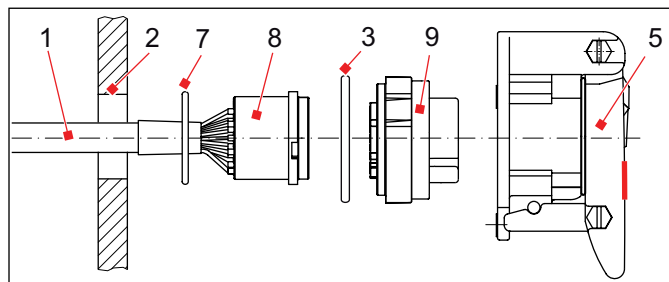

Fig. 11: Coupling receptacle with replacement insert and crimp adapter (18-pole) with assembled connector cable

- 1 Connector cable, completely assembled
- 2 Vehicle wall with prepared mounting holes
- 3 O-ring for replacement insert
- 5 Empty receptacle with inserted rubber seal (lamella ring)
- 7 O-ring for crimp adapter
- 8 Crimp adapter, completely assembled
- 9 Replacement insert

- ▶ Fit the replacement insert (9) in the specified coding position onto the assembled crimp adapter (8).
- ▶ Slide the replacement insert (9) plugged together with the crimp adapter (8) with the slot (K) into the guideway (L) on the top of the coupling receptacle (5).

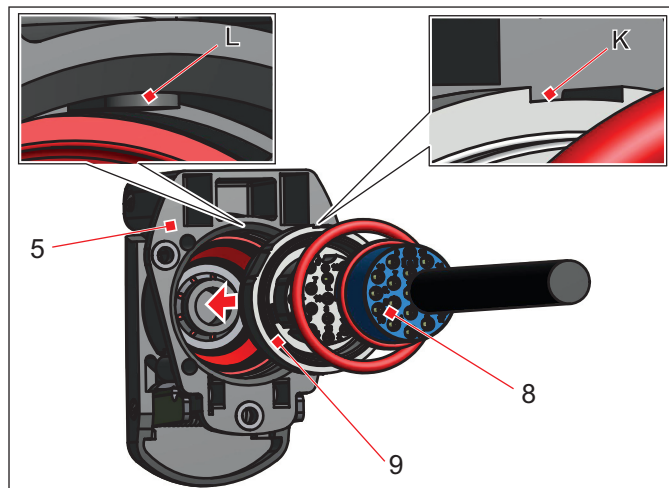

Fig. 12: Coding position with slots (K) on the replacement insert and guideways (L) in the coupling receptacle

NOTICE

To ensure the proper operation, the socket insert and the contacts may not be under tension.

- ▶ Make sure that the specified bending radius is observed when laying the cables: 8 x cable diameter = 145 mm
- ▶ Slightly fasten the receptacle (5) with the three M6 cylinder screws (or alternatively with four M6 cylinder screws) to the vehicle wall (2).
- ▶ Check if the two O-rings (3/7) of the replacement insert and crimp adapter as well as the rubber seal (lamella ring) are properly in place. Align seals where applicable.
- ▶ Adjust all of the parts and fasten the M6 cylinder screws.
Tightening torque: 10.5 Nm for screws of steel with strength class 8.8.

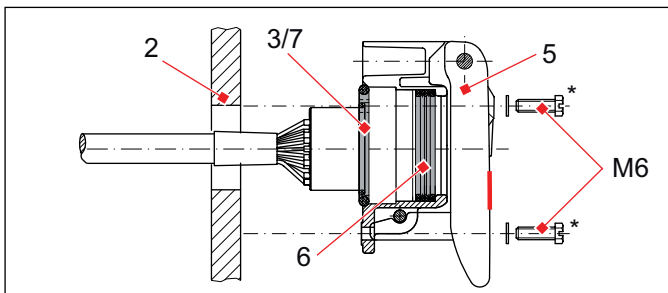

Fig. 13: Screw coupling receptacle with crimp adapter and replacement insert to vehicle wall
* Diameter for all fixing and securing elements, such as screw heads: 12.5 mm max.

Test

- ▶ Check that all of the installed parts are in the correct position and function properly.
- ▶ Make sure that there are no undue tensile, pressure, flexing and torsion loads on the connection cables.
- ▶ Check the functionality of the receptacle lid.

Commissioning

	<p>⚠ DANGER</p>
	<p>In the case of a contact of the traction current line with the vehicle, the coupling receptacle may be highly energised. Deadly hazard!</p> <ul style="list-style-type: none"> ▶ Before commissioning the receptacle, a high voltage test must be carried out.

- ▶ Before commissioning the receptacle, it must be tested in accordance with EN 50215.

5.6 Disassembly of Replacement Insert and Crimp Adapter

Special Tools Required

Pull off tool for pulling off the crimp adapter from the replacement insert, ordering code: UIC DWZ, also refer to chapter „8. Special Tools“.

Disassembly

- ▶ Dismount the coupling receptacle from the vehicle wall / mounting surface and take it off from the replacement insert.
- ▶ Pull the replacement insert (A) with crimp adapter (B) and connector cable (C) out of the interior of the vehicle through the mounting hole in the vehicle wall so that the replacement insert (A) and the crimp adapter (B) are exposed (Fig. 14).

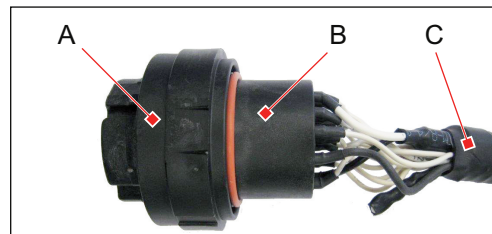

Fig. 14: Replacement insert (A) with crimp adapter (B) and connector cable (C)

- ▶ Take the pull off tool and prepare as follows:
 - 1) Release the 2 screws (D) of the pull off tool until the springs (E) are stress-free (Fig. 15).
 - 2) Totally unscrew screw (F) so that the clamp of the pull off tool can be opened.
- ▶ Then lay the pull off tool around the crimp adapter in such a way that the retaining clips (G) touch the edge of the replacement insert.
- ▶ Screw down screw (F) until the pull off tool firmly clasps the crimp adapter.

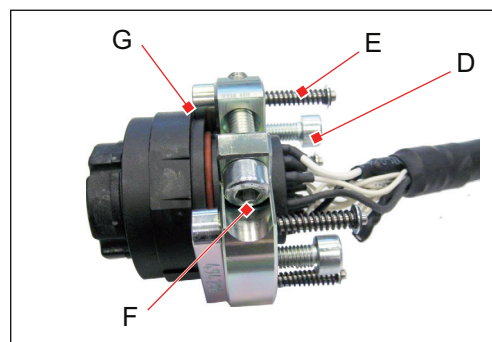

Fig. 15: Put on pull off tool

- ▶ Tighten the 2 screws (D) until the crimp adapter loosens from the replacement insert and can be taken off (Fig. 16).

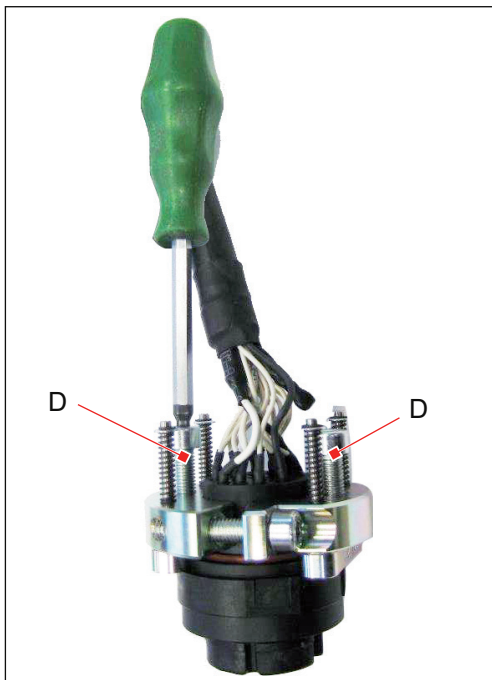

Fig. 16: Pull off crimp adapter from the replacement insert

- ▶ To remove the pull off tool, release screw (F) and open the clamp (Fig. 17).

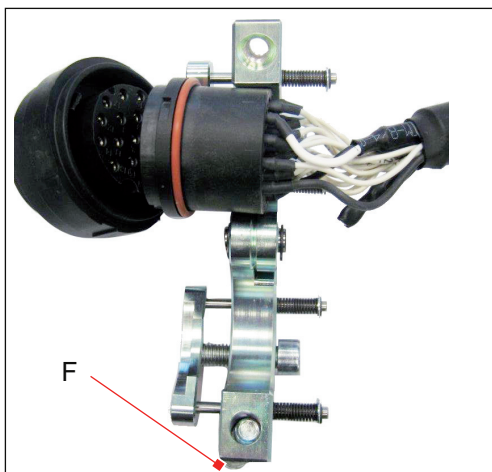

Fig. 17: Remove pull off tool

5.7 Installing the Dummy Receptacle

Installation

The dummy receptacle is installed in the same way as the coupling receptacles. The dummy receptacle uses an unpopulated insert without cable and contacts instead of the assembled socket insert with connector cable or replacement insert with crimp adapter.

- ▶ Install the dummy receptacle as described under „5.3 Installing Coupling Receptacles“.
- ▶ Insert an unpopulated insert instead of the assembled socket insert/replacement insert.

Test

- ▶ Check that all of the installed parts are in the correct position and function properly.
- ▶ Check the functionality of the receptacle lid.

Commissioning

⚠ DANGER	
	<p>In the case of a contact of the traction current line with the vehicle, the dummy receptacle may be highly energised. Deadly hazard!</p> <ul style="list-style-type: none"> ▶ Before commissioning the dummy receptacle, a high voltage test must be carried out.

- ▶ Before commissioning the dummy receptacle, it must be tested in accordance with EN 50215.

5.8 Installing Wall-mount Cable Glands for Cable Plugs with Connector Cable

The connector cables have to be installed in such a way that they are free from undue tensile, pressure, flexing and torsion loads.

We recommend using the UIC KK D2 wall-mount cable gland for installation on the vehicle body.

Preparing measures

For the installation of wall-mount cable glands, a mounting hole with 30 mm diameter has to be provided in the vehicle wall.

Installation

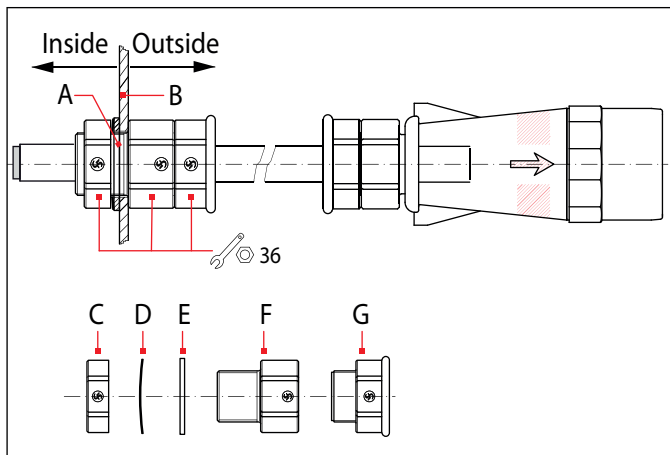

Fig. 18: Wall-mount cable gland UIC KK D2

- A Mounting hole \varnothing 30 mm
- B Vehicle wall
- C Nut
- D Spring washer
- E Supporting ring
- F Strain relief fitting
- G Tension screw

NOTICE

To ensure the proper operation, the socket insert and the contacts may not be under tension.

- ▶ Make sure that the specified bending radius is observed when laying the cables:
 $8 \times \text{cable diameter} = 145 \text{ mm}$

- ▶ Thread tension screw (G) and strain relief (F) on the open end of the assembled connector cable.
- ▶ Lead the connector cable from the outside through the mounting hole (A) (\varnothing 30 mm) in the vehicle wall (B) to the inside.
- ▶ Thread supporting ring (E), spring washer (D) and nut (C) from the inside on the connector cable and attach to the thread of the strain relief (F).
- ▶ Screw nut (C) only slightly on the thread of the strain relief (F).
- ▶ Adjust all of the parts and fasten nut (C).
 (Tightening torque: 3 Nm)
- ▶ Establish strain relief and screw clamping screw (G) into the strain relief (F).
 (Tightening torque: 3 Nm)

Test

- ▶ Check that all of the installed parts are in the correct position.
- ▶ Make sure that there are no undue tensile, pressure, flexing and torsion loads on the connection cables.
- ▶ All contacts must be aligned, i.e. they must not be crooked.
- ▶ Make sure the strain relief fits properly.

Commissioning

	⚠ DANGER
<p>In the case of a contact of the traction current line with the vehicle, the cable plug with connector cable may be highly energised. Deadly hazard!</p> <ul style="list-style-type: none"> ▶ Before commissioning the cable plug with connector cable, a high voltage test must be carried out. 	





- ▶ Before commissioning the plug connection, it must be inspected in accordance with EN 50215.

5.9 Storage of Connector Cables

When storing double ended connector cables in the carriages or driver's cabins, make sure the bending radius (based on the cable type) is observed and that the cable is protected against shocks and dirt.

6. Plugging Procedure

For the plugging procedure observe the requirements in chapter „2.3 *Intended Use*“.

	<p>⚠ WARNING</p> <p>Dirt, moisture, snow and ice in the interior of coupling receptacles or dummy receptacles contaminate the plug. The coupling of a contaminated plug to the coupling receptacle may lead to electric shock, short circuit and damage to the connectors!</p> <ul style="list-style-type: none"> ▶ Always check if the interior of the receptacles is free from dirt, moisture, snow and ice before inserting a plug into a coupling receptacle or a dummy receptacle. ▶ Do not insert a plug into a receptacle when the latter is contaminated, moist or contaminated with snow and ice. ▶ Remove dirt, moisture, snow and ice without residues from the interior of receptacles and from the plug. ▶ Never couple a contaminated plug to the coupling receptacle.
	<p>⚠ WARNING</p> <p>The plugging and disconnecting of the connectors on-load can cause electric arcs. When explosive substances or ignition sources of any kind are nearby, there is a risk of fire and explosion!</p> <ul style="list-style-type: none"> ▶ Never plug and disconnect the connectors on-load.
	<p>⚠ CAUTION</p> <p>The connectors contain sharp-edged components as well as components which are subject to mechanical tension. Crushing hazard / risk of injury!</p> <ul style="list-style-type: none"> ▶ Wear safety gloves when plugging and disconnecting the connectors.
	<p>⚠ CAUTION</p> <p>The connectors may grow warm during operation and they may become hot depending on the ambient temperature and the conditions of use. Risk of burn to the hands!</p> <ul style="list-style-type: none"> ▶ Wear safety gloves when plugging and disconnecting the connectors in the case of a high ambient temperature.

NOTICE

Inappropriate handling when plugging or disconnecting may damage the connectors. The functional safety of the connectors is no longer guaranteed when parts are damaged.

- ▶ Make sure that the slots (1) and guideways (2) of receptacle and plug always interlock when plugging (*Fig. 19*)!
- ▶ Take care that plug and receptacle do not tilt and that they are plugged without force.
- ▶ Make sure before the plugging procedure that plug and receptacle as well as the hinged lid of the receptacle are not contaminated. Remove any existing dirt.
- ▶ Make sure that when not mated,
 - the plug is always inserted into a dummy receptacle,
 - the hinged lid of receptacles is closed according to its intended use.
- ▶ Open the hinged lid of the receptacle by an angle of at least 110° but not more than 130° (refer to *Fig. 20*). Overstretching of the hinged lid may shorten the operational life span of the torsion spring and may damage the hinge mechanism.
- ▶ Always close the hinged lid by hand, don't let it slam!

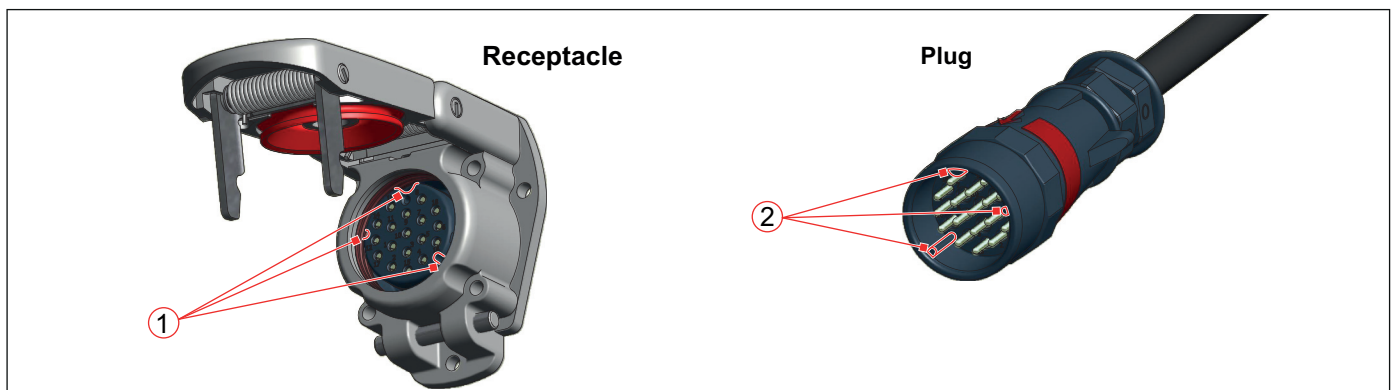

Fig. 19: Slots (1) on receptacle and guideways (2) on plug



Note:

In case of a very low or very high ambient temperature which approximates the limits of the allowable operating temperature range specified in our catalogue *F120.en* in section "*Specifications*",

- a higher effort may be needed for the plugging and unplugging and
- the operational life span of plug and coupling receptacle may thus be reduced due to increased wear and tear.

6.1 Plugging

- ▶ Open the hinged lid (3) of the coupling receptacle (4).
- In doing so, observe the opening angle:
 - at least 110°
 - but not more than 130°

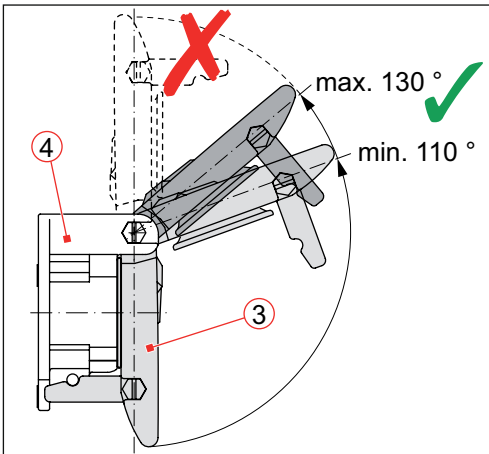

Fig. 20: Open the hinged lid (3) of the coupling receptacle (4): Opening angle at least 110°, at most 130°

- ▶ Position the plug (5) in such a way that the arrow (6) on the plug is congruent with the arrow (7) on the hinged lid of the coupling receptacle (4).



Fig. 21: Align arrow (6) on plug congruent with arrow (7) on the receptacle lid

Then insert the plug in such a way that the guide-ways (2) in the plug slide without much effort into the slots (1) of the receptacle (refer to **Fig. 19**).

In doing so, take care

- that plug and receptacle are aligned axially (a plug set diagonally by more than 8° cannot be plugged by hand anymore!),
- that the plug is completely (flush) inserted in the receptacle.

- ▶ After that close the hinged lid (3) by hand until the locking mechanism (8) on lid and plug latches.

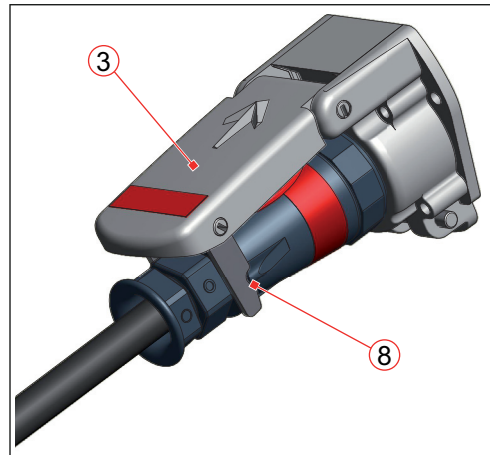

Fig. 22: Close the hinged lid (3) by hand until the locking mechanism (8) on lid and plug latches

6.2 Unplugging

- ▶ Open the hinged lid (3) of the coupling receptacle (4). In doing so, observe the opening angle:
 - at least 110°
 - but not more than 130°
- ▶ Hold the hinged lid (3) and take off the plug (5) from receptacle (4). Only pull on the plug, not on the cable.
- ▶ Close the hinged lid (3) by hand until the locking mechanism (9) on lid and receptacle shell latches.

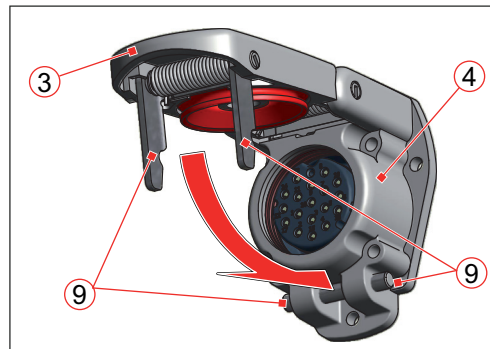



Fig. 23: Close the hinged lid (3) of the coupling receptacle (4) by hand until the locking mechanism (9) latches

7. Maintenance

Note the expert knowledge which is essential for carrying out maintenance work, mentioned in chapter „2. General and Security Information“.

	⚠ DANGER
	<p>The connectors contain components that carry voltage. Risk of electric shock! Always observe the following safety regulations before beginning any work on electrical constructions:</p> <ul style="list-style-type: none"> ▶ Disconnect ▶ Ensure that it is not possible to reconnect unintentionally ▶ Clearly mark your work area ▶ Make sure that there is no voltage present ▶ Earth and short circuit the installation ▶ Insulate or cover adjacent energized parts ▶ Only an electrically skilled person may determine if there is no voltage present

All of the maintenance activities that may be carried out on the connectors by skilled personnel are listed below.

7.1 Intervals for Checks and Maintenance

The condition of the connectors depends on environmental influences as well as proper use. To ensure the correct function and a prolonged operational life span of the connectors, the following checks and maintenance must be performed regularly.

Checks / Maintenance	Interval
Visual inspection of - plug - coupling receptacle - receptacle lid - cable - contacts (in plug and receptacle) - contact inserts (in plug and receptacle) - strain relief fitting - dummy receptacle with socket insert without contacts	▶ At every plugging
Complete maintenance, where all parts of the connectors are checked for damage and correct function	▶ Every 35 to 42 days

7.2 Visual and Functional Inspection at each Plugging

At every plug-in, all elements of the connector must be visually and functionally inspected.

NOTICE
<p>The functional reliability of the connector is no longer given should there be any visible damage to the cable, plug, receptacle housing, hinged lid, contacts, contact inserts, seals or to any other components of the connectors.</p> <p>▶ Immediately replace all damaged parts.</p>

7.3 Visual and Functional Inspection/ Maintenance of Coupling Receptacle and Dummy Receptacle

In addition to the visual inspection at every plugging, a complete maintenance, where all parts of the connectors are checked for damages and correct function, must be performed every 35 to 42 days.

Connector element	Visual and functional inspection	Measures
Receptacle shell and receptacle lid	Check for: <ul style="list-style-type: none"> ▶ low spring tension when opening the receptacle lid ▶ ease of movement when plugging ▶ dirt ▶ damage or wear and tear on shell, contacts, contact insert ▶ bent contacts ▶ damage or abrasion of slots/guideways ▶ cracks and ruptured patches ▶ loose or missing fastening elements ▶ tears and porosity in the lid seal 	In case of defects: <ul style="list-style-type: none"> ▶ remove existent dirt without leaving any residue ▶ immediately replace damaged parts
Torsion springs at receptacle lid	Check for: <ul style="list-style-type: none"> ▶ insufficient lubrication of torsion springs ▶ broken or overstretched torsion springs ▶ secure and firm fit of torsion springs 	In case of defects: <ul style="list-style-type: none"> ▶ lubricate torsion springs with Molykote ▶ immediately replace damaged parts
Locking mechanism of the receptacle lid	Close the receptacle lid until the locking mechanism latches and check for: <ul style="list-style-type: none"> ▶ damage or abrasion ▶ free movement of the locking mechanism ▶ proper operation of the locking mechanism ▶ secure and firm fit of the locking mechanism 	In case of defects: <ul style="list-style-type: none"> ▶ immediately replace damaged parts
Sealing ring (O-ring) on the mounting flange of the receptacle	Check for: <ul style="list-style-type: none"> ▶ tears and porosity on the sealing ring (O-Ring) ▶ proper fit of the sealing ring (O-Ring) 	In case of defects: <ul style="list-style-type: none"> ▶ immediately replace damaged O-rings
Rubber seal (lamella ring) in the receptacle shell	Check for: <ul style="list-style-type: none"> ▶ tears and porosity on the rubber seal (lamella ring) ▶ proper fit of the rubber seal (lamella ring) 	<ul style="list-style-type: none"> ▶ Immediately replace a damaged rubber seal (lamella ring)
Socket insert (for receptacles)	Check for: <ul style="list-style-type: none"> ▶ visible damage ▶ dirt ▶ signs of moisture ▶ cracks and ruptured patches ▶ tears and porosity on the sealing ring (O-Ring) 	In case of defects: <ul style="list-style-type: none"> ▶ remove existent dirt or moisture without leaving any residue ▶ immediately replace damaged parts
Replacement insert/ Crimp adapter	Check for: <ul style="list-style-type: none"> ▶ visible damage ▶ dirt ▶ signs of moisture ▶ cracks and ruptured patches ▶ tears and porosity on the sealing ring (O-Ring) 	In case of defects: <ul style="list-style-type: none"> ▶ remove existent dirt or moisture without leaving any residue ▶ immediately replace damaged parts
Socket contacts	Check for: <ul style="list-style-type: none"> ▶ visible damage ▶ dirt ▶ signs of moisture ▶ pushed back contacts ▶ a loose fit of the contacts in the socket insert 	In case of defects: <ul style="list-style-type: none"> ▶ remove existent dirt or moisture without leaving any residue ▶ immediately replace damaged parts

7.4 Visual and Functional Inspection/Maintenance of the Cable Plug

Connector element	Visual and functional inspection	Measures
Plug shell	Check for: <ul style="list-style-type: none"> ▶ ease of movement when plugging ▶ for damage or abrasion of plug shell, contacts, plug insert ▶ damage of the guide bead ▶ damage on the edge of the locking mechanism ▶ the functioning of the strain relief fitting ▶ dirt ▶ cracks and ruptured patches ▶ loose or missing fastening elements 	In case of defects: <ul style="list-style-type: none"> ▶ remove existent dirt without leaving any residue ▶ immediately replace damaged parts
Plug ring	Check for: <ul style="list-style-type: none"> ▶ damage to the plug ring ▶ tears and porosity on the sealing ring (O-Ring) ▶ proper fit of the sealing ring (O-Rings) 	In case of defects: <ul style="list-style-type: none"> ▶ immediately replace damaged parts
Pin insert (for plugs)	Check for: <ul style="list-style-type: none"> ▶ visible damage ▶ dirt ▶ signs of moisture ▶ cracks and ruptured patches ▶ tears and porosity on the sealing ring (O-Ring) 	In case of defects: <ul style="list-style-type: none"> ▶ remove existent dirt or moisture without leaving any residue ▶ immediately replace damaged parts
Pin contacts	Check for: <ul style="list-style-type: none"> ▶ visible damage ▶ dirt ▶ signs of moisture ▶ bent or pushed back contacts ▶ a loose fit of the contacts in the pin insert 	In case of defects: <ul style="list-style-type: none"> ▶ remove existent dirt or moisture without leaving any residue ▶ schadhafte Teile unverzüglich erneuern

8. Special Tools

- ▶ Pull off tool UIC-DWZ for pulling off the crimp adapter from the replacement insert (ordering code UIC-DWZ)

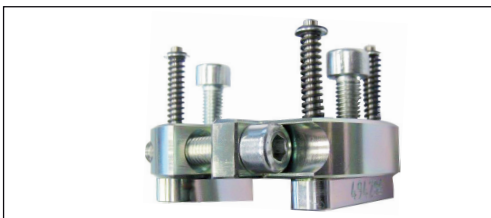

Fig. 24: Pull off tool UIC-DWZ

- ▶ Extraction tool AWZ-B for contacts type H: SHC-x, BHC-x (ordering code AWZ-B)



Fig. 25: Extraction tool AWZ-B

- ▶ Crimping tool CWZ-600-1 for connection cross sections 0.14 mm² ... 6 mm² (ordering code CWZ-600-1)

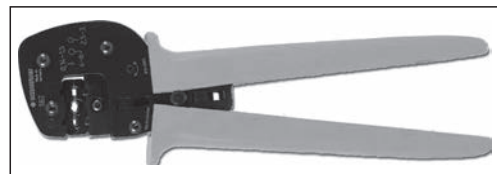

Fig. 26: Crimp tool CWZ-600-1

NOTICE

Only crimping tools authorised by Schaltbau GmbH may be used.

9. Spare Parts

Spare parts for UIC 558 receptacles (Fig. 27 and Fig. 28)		
Pos.	Description	Pcs
1	Empty receptacle	1
2	Rubber seal (lamella ring)	1
3	Socket insert	1
4	O-Ring 52x5	1
5	Replacement insert	1
6	Crimp adapter	1
7	O-Ring 39x2,5	1

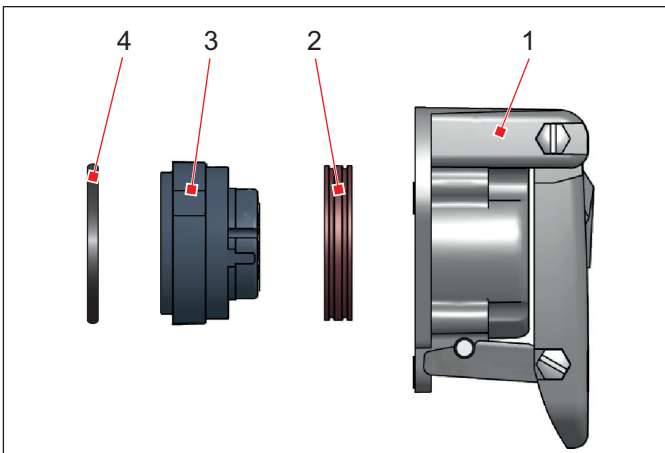

Fig. 27: Spare parts for UIC 558 receptacles with socket insert

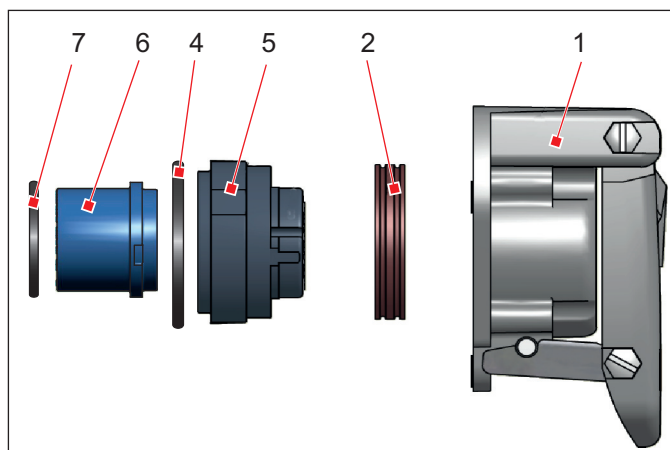

Fig. 28: Spare parts for UIC 558 receptacles with replacement insert and crimp adapter

Spare parts for UIC 558 cable plugs (Fig. 29)		
Pos.	Description	Pcs
8	UIC Plug ring	1
9	Pin insert	1
10	O-Ring 43x2 lubricated with Vaseline (white Vaseline DAB9 Standard)	1
11	Plug shell	1
12	Sealing ring	1
13	Compression ring	1
14	Strain relief fitting	1
15	Tension screw	1

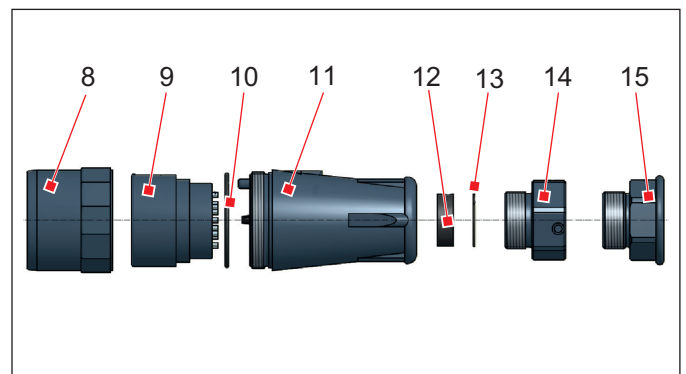

Fig. 29: Spare parts for UIC 558 cable plugs

10. Technical Data

Specifications and information on the material characteristics for the connectors in the UIC 558 series are given in our catalogue *F120.en*.

Due to our continuous improvement programme, the design of our products can be modified at any time. So some features may differ from the descriptions, specifications and drawings in the catalogue. You can download the latest update of the catalogue at: schaltbau.info/download1en. The updated catalogue renders the previous issue invalid.

Schaltbau GmbH

For detailed information on our products and services visit our website – or give us a call!

Schaltbau GmbH
Hollerithstrasse 5
81829 Munich
Germany



Phone +49 89 9 30 05-0
Fax +49 89 9 30 05-350
Internet www.schaltbau.com
e-Mail contact@schaltbau.de

with compliments:



The production facilities of Schaltbau GmbH have been IRIS certified since 2008.



Certified to DIN EN ISO 14001 since 2002. For the most recent certificate visit our website.



Certified to DIN EN ISO 9001 since 1994. For the most recent certificate visit our website.

Electrical Components and Systems for Railway Engineering and Industrial Applications

Connectors

- Connectors manufactured to industry standards
- Connectors to suit the special requirements of communications engineering (MIL connectors)
- Charging connectors for battery-powered machines and systems
- Connectors for railway engineering, including UIC connectors
- Special connectors to suit customer requirements

Snap-action switches

- Snap-action switches with positive opening operation
- Snap-action switches with self-cleaning contacts
- Snap-action switch made of robust polyetherimide (PEI)
- Snap-action switch with two galvanically isolated contact bridges
- Special switches to suit customer requirements

Contactors Emergency disconnect switches

- Single and multi-pole DC contactors
- High-voltage AC/DC contactors
- Contactors for battery powered vehicles and power supplies
- Contactors for railway applications
- Terminal bolts and fuse holders
- DC emergency disconnect switches
- Special contactors to suit customer requirements

Electrics for rolling stock

- Equipment for driver's cab
- Equipment for passenger use
- High-voltage switchgear
- High-voltage heaters
- High-voltage roof equipment
- Equipment for electric brakes
- Design and engineering of train electrics to customer requirements