

4

Electrics for Rolling Stock

SD, SE, SDE, SCO series

**Multipole switchgear
for rail vehicles:
Disconnecting switches,
Earthing Switches,
Disconnecter with Earthing Switches,
Change-Over-Switches**

600 V to 3 kV

Catalogue F184.en

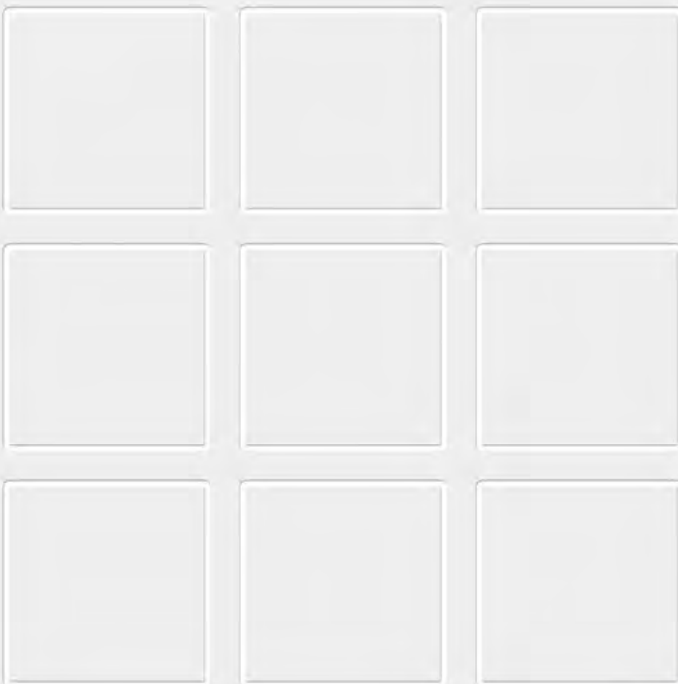

SD, SE, SDE, SCO Multipole switchgear for voltages up to 600 kV to 3 kV

Switchgear for rolling stock

The switches of series SD, SE, SDE and SCO have a modular design and can be used for the function disconnect, earthing, disconnect and earthing as well as switching between two circuits (change-over).

Switching between the individual switch positions is permissible without load only.

The number of circuits can be individually adapted to the respective requirements. A combination of the above-mentioned functionalities within one device is simple to implement. The modularity is given not only to the number and functions of the switching chambers, but also to the possibilities of actuation by drive units.

Applications

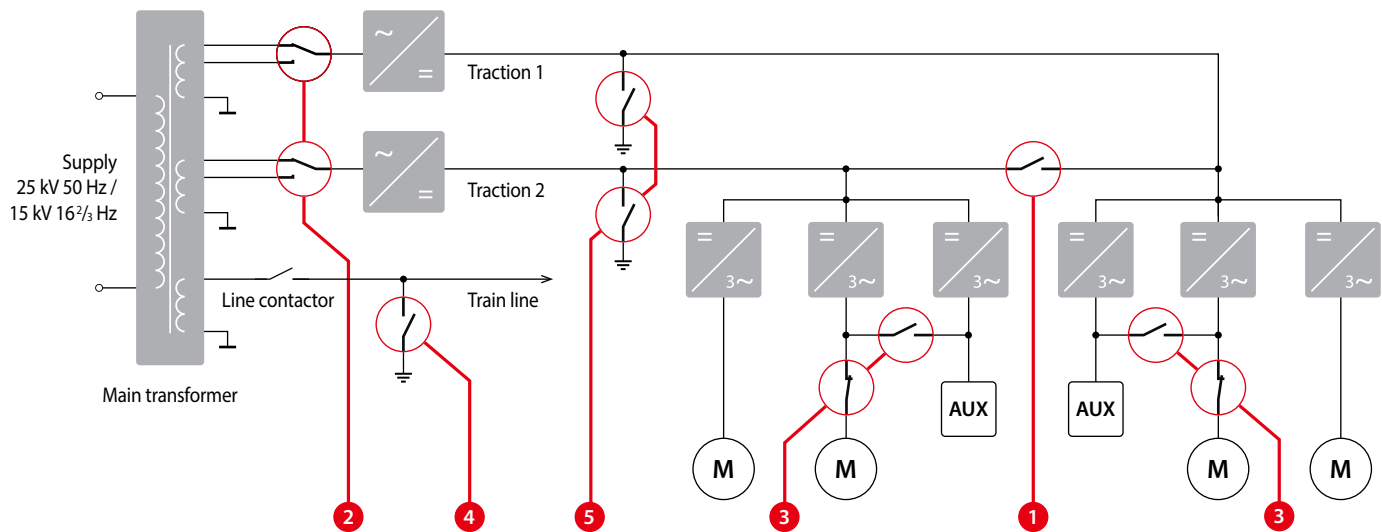

Use of functions disconnect, earthing, and change over-switching in railway applications for all rolling stock for voltage range up to 3 kV max:

- Traction inverter
- Auxiliary inverter
- Train power supply lines

- 1 **DC link:** interconnection of traction converters in the event of a fault
- 2 **Transformer switch:** switch for changing over from 25 kV 50 Hz auf 15 kV 16²/₃ Hz on main transformer
- 3 **Disconnector and change over switch:** changes output of a traction inverter to the auxiliary loads (if auxiliary inverter is broken)
- 4 **Disconnecting and earthing** of high voltage busbar(s)
- 5 **Earthing** of circuits inside inverters

Further configurations: disconnecting and earthing of various circuits inside inverters according to customer requirements!

Standards

- **EN 50155:** Railway applications – Electronic equipment used on rolling stock
- **EN 50121-3-2:** Railway applications – Electromagnetic compatibility – Part 3-2: Rolling stock – Apparatus
- **EN 50124-1:** Railway applications – Insulation coordination – Part 1: Basic requirements – Clearances and creepage distances for all electrical and electronic equipment
- **EN 61373:** Railway applications – Rolling stock equipment – Shock and vibration tests
- **EN 60077-1:** Railway applications – Electric equipment for rolling stock – Part 1: General service conditions and general rules
- **EN 60077-2:** Railway applications – Electric equipment for rolling stock – Part 2: Electrotechnical components – General rules
- **EN 45545:** Railway applications – Fire protection on railway vehicles.
- **NF 16101/NF 16102:** Fire test to railway components

Features

Four different types of drive units are available:

1. Manually operated by lever, mechanical interface on customer request
2. Electrically operated by motor-gear-unit, end positions controlled by digital encoder
3. Electrically operated by linearmotor
4. Pneumatically operated drive (upon request)

Individual assembly of switching chambers / main contacts:

- NO** – Normally open contact
NC – Normally closed contact
CO – Change-over-switch

- Modular, compact and rugged design
- Switching to different switching positions allowed without load only
- Nominal voltage 600 V DC up to 3 kV DC
- Conventional thermal current 500 A per switching chamber, parallel switching of switching chambers is possible for higher rated currents
- Configurable up to 10 switching chambers
- 2, 3 or 4 switching positions can be implemented, for variant linear motor maximal 3 positions
- Key locking systems by means of a key switches, square keys and/or padlocks are possible
- Auxiliary switches for all positions are provided
- Detection and indication of high voltage by means of HV sensor, optional
- Optional integrated high voltage sensors detects and indicates if high voltage circuit is under load by flashing of 3 red LEDs. It indicates AC and DC voltages from 40 V to 4.2 kV
- Mechanical interfaces such as front panel, housing and so on can be adapted to installation conditions of the E-containers, racks, etc.
- Easy and low cost maintenance:
 - Easy inspection and low life cycles cost (LCC)
 - Preventive maintenance – a proper greasing is required only. This activity can be performed directly on train, special inspection points on the switching chamber are available
 - Corrective maintenance – a service kit consisting 4 different spare parts is sufficient to repair switching chamber and/or active (movable) components

Ordering code

Example: **SD 03 MA 00 110 01**

<p>Series</p> <p>SD Disconnecting switch SE Earthing switch SDE Disconnecter and earthing switch, combined SCO Change-over switch</p> <p>Nominal voltage</p> <p>03 $U_n = 3 \text{ kV DC}$</p> <p>Drive unit / activation unit</p> <p>MA Manual MG Motor-driven: motor gear unit ML Motor-driven: linear motor MP Pneumatic drive (upon request)</p> <p>Switching capability, Making</p> <p>00 Making: Without load</p> <p>Control voltage</p> <p>24 / 36 / 72 / 110 V DC</p>	<p>Running number of variants; list of special design which are not fixed in ordering code above, like: Design of front panel, different keylock systems, number and configuration of the switching chambers, different installation variants on-roof / in-roof, ...</p>	<p>Special design</p> <p>Special design 1 01 Special design 2 02 Special design 3 03 Special design 4 04 Special design</p>
---	---	---



The multipole switchgear on this catalogue are individual configurable for your application, but based on standard components.



Do you need support for a special application? Please contact us! We would be glad to assist you in the selection of the contactor that suits your application best.

Specifications

SD, SE, SDE, SCO series

Series Switch for	SD Disconnecting	SE Earthing	SDE Disconnecting and earthing	SCO Change-over
Switching chamber				
Type of voltage	DC, AC (f < 60 Hz)	DC, AC (f < 60 Hz)	DC, AC (f < 60 Hz)	DC, AC (f < 60 Hz)
Number of fixed contacts, configuration	1 ... 10, NC / NO / CO	1 ... 20, NC / NO / CO	1 ... 20, NC / NO / CO	1 ... 20, NC / NO / CO
Nominal voltage U_n	3,000 V	3,000 V	3,000 V	3,000 V
Rated operating voltage U_e	3,600 V	3,600 V	3,600 V	3,600 V
Rated insulation voltage U_{Nm}	4,800 V	4,800 V	4,800 V	4,800 V
Rated impulse withstand voltage U_{Ni}	25 kV	25 kV	25 kV	25 kV
Pollution degree	PD3	PD3	PD3	PD3
Overvoltage category	OV3	OV3	OV3	OV3
Conventional thermal current I_{th}	500 A *1	---	500 A *1	500 A *1
Component category / class (IEC 60077-2)	A4 / C2	A4 / C2	A4 / C2	A4 / C2
Making capacity, breaking capacity	without load	without load	without load	without load
Rated short-time withstand current I_{cw} T < 100 ms / T < 25 ms	4 kA / 50 kA	4 kA / 50 kA	4 kA / 50 kA	4 kA / 50 kA
Critical current range	none	none	none	none
Design				
Contact blades, shape	/ / < / X	/ / < / X	/ / < / X	/ / < / X
Contact blades, material	Cooper, silver plated	Cooper, silver plated	Cooper, silver plated	Cooper, silver plated
Fixed contacts, material	Cooper, silver plated	Cooper, silver plated or stainless steel	Cooper, silver plated	Cooper, silver plated
Terminals	Bolt, M8	Bolt, M8	Bolt, M8	Bolt, M8
Torque	20 Nm max.	20 Nm max.	20 Nm max.	20 Nm max.
Auxiliary contacts				
Number / type	1 per position / S826 (Schaltbau snap-action switches, see catalogue D26) or *2			
Contact material	Silver			
S826 switching capacity (T = 5 ms)	16 A @ 24 V DC; 13.5 A @ 80 V DC; 7 A @ 110 V DC			
Terminals	Terminal block, connector or *2			
Drive unit				
Motor voltage U_{SM}	24 / 36 / 72 / 110 V DC			
Control voltage encoder U_{SE}	24 V DC			
Tolerance motor and control voltage	-30 % ... +25 % U_s			
Switching positions				
Manual: lever or *2	4 max. sequence 1-2-3-4-3-2-1			
Motor gear unit with digital encoder	4 max. sequence 1-2-3-4-1-2-3-4-...			
Linear motor unit with digital encoder	3 max. sequence 1-2-3-2-1			
Change over time				
Motor gear unit with digital encoder	approx. 3 sec			
Linear motor unit with digital encoder	approx. 3 sec, 8 sec max. *3			
Terminals	Terminal block, connector or *2			
Interlock *2	Key lock switches / square key locks / key multiplier / pad locks / electromagnetic			
Mounting				
Mounting	4x Screw M10 or *2			
Position	horizontal, vertical			
Degree of protection				
IP00				
Mechanical endurance (IEC 60077-2, IEC 60077-2)				
125,000 operating cycles				
Vibration / Shock (IEC 61373)				
Category 1, Class B				
Housing				
Switching chamber	Fiberglass reinforced plastic			
Frame	Stainless steel or *2			
Ambient conditions				
Operating temperature	Manual: -50 °C ... +40 °C / Motor gear unit/linear motor unit: -40 °C ... +70 °C			
Storage temperature	Manual: -50 °C ... +70 °C / Motor gear unit/linear motor unit: -40 °C ... +85 °C			
Altitude	< 2,000 m above sea level			
Humidity (EN 50125-1)	< 75 % im yearly average			
Weight				
Manual	approx. 25 kg *4			
Motor gear unit	approx. 35 kg *4			
Linear motor unit	approx. 30 kg *4			

*1 Per switching chamber

*2 Customer specific / upon request

*3 Depending on the number of switching chambers

*4 Switchgear with 3 switching chambers, each additional plus approx. 3 kg

Switching chamber Disconnecting, change-over, earthing

SD, SDE, SCO series

- **Disconnecting, change-over**
Switching chamber with 2 positions and 4 blade contacts

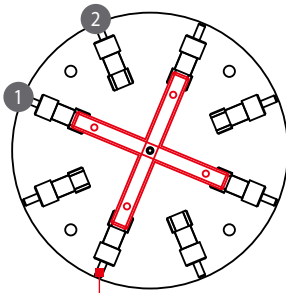

Terminal M8 ①, ② switching positions

- **Disconnecting, change-over**
Switching chamber with 4 positions and 3 blade contacts

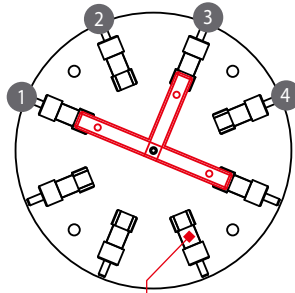

Fixed contact ① ... ④ switching positions

- **Disconnecting, change-over**
Switching chamber with 4 positions and 2 blade contacts

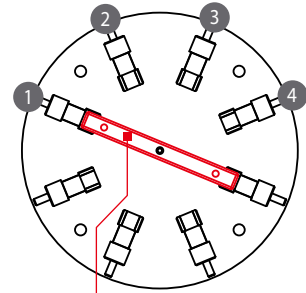

Contact blade ① ... ④ switching positions

- **Disconnecting, earthing**
Switching chamber with 2 positions and 4 blade contacts for earthing of 3 circuits

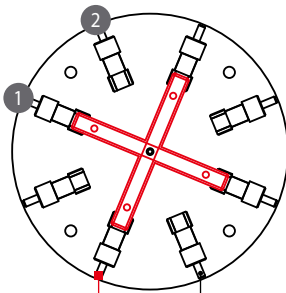

Terminal M8 ② earthed position

- **Disconnecting, change-over, earthing**
Switching chamber with 4 positions and 3 blade contacts for earthing of 2 circuits

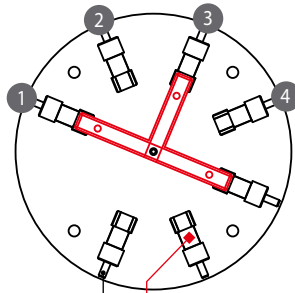

Fixed contact ③ earthed position

- **Disconnecting, change-over, earthing**
Switching chamber with 4 positions and 2 blade contacts for earthing of 1 circuit

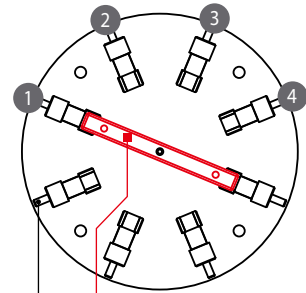

Contact blade ④ earthed position

Switching chamber Earthing

SE series

- **Earthing**
Switching chamber with 4 blade contacts for earthing of 4 circuits

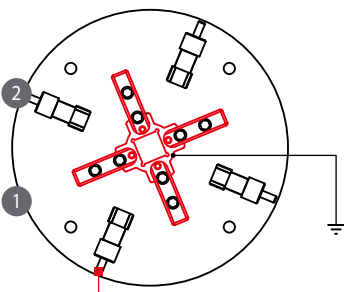

Terminal M8 ② earthed position

- **Earthing**
Switching chamber with 3 blade contacts for earthing of 3 circuits

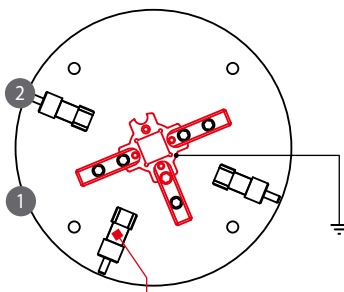

Fixed contact ② earthed position

- **Earthing**
Switching chamber with 2 blade contacts for earthing of 2 circuits

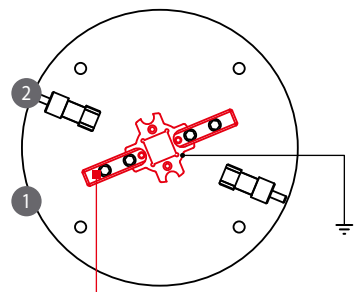

Contact blade ② earthed position

i Shown are example configurations
We are happy to realize your required switching configuration. Do not hesitate to contact us.
Our aim is to implement your switching function by the optimum number of switching chambers.

i The requested switching configuration will be realized by the:

- Number of switching chambers
- Number of switching positions
- Number and type of blade contacts
- Type of actuation

SD/SE/SDE/SCO 03 MA xxx xx Dimension diagram

SD, SE, SDE, SCO series

- Switchgear with 2 HV switching chambers, manual actuation and HV indicators (LED)

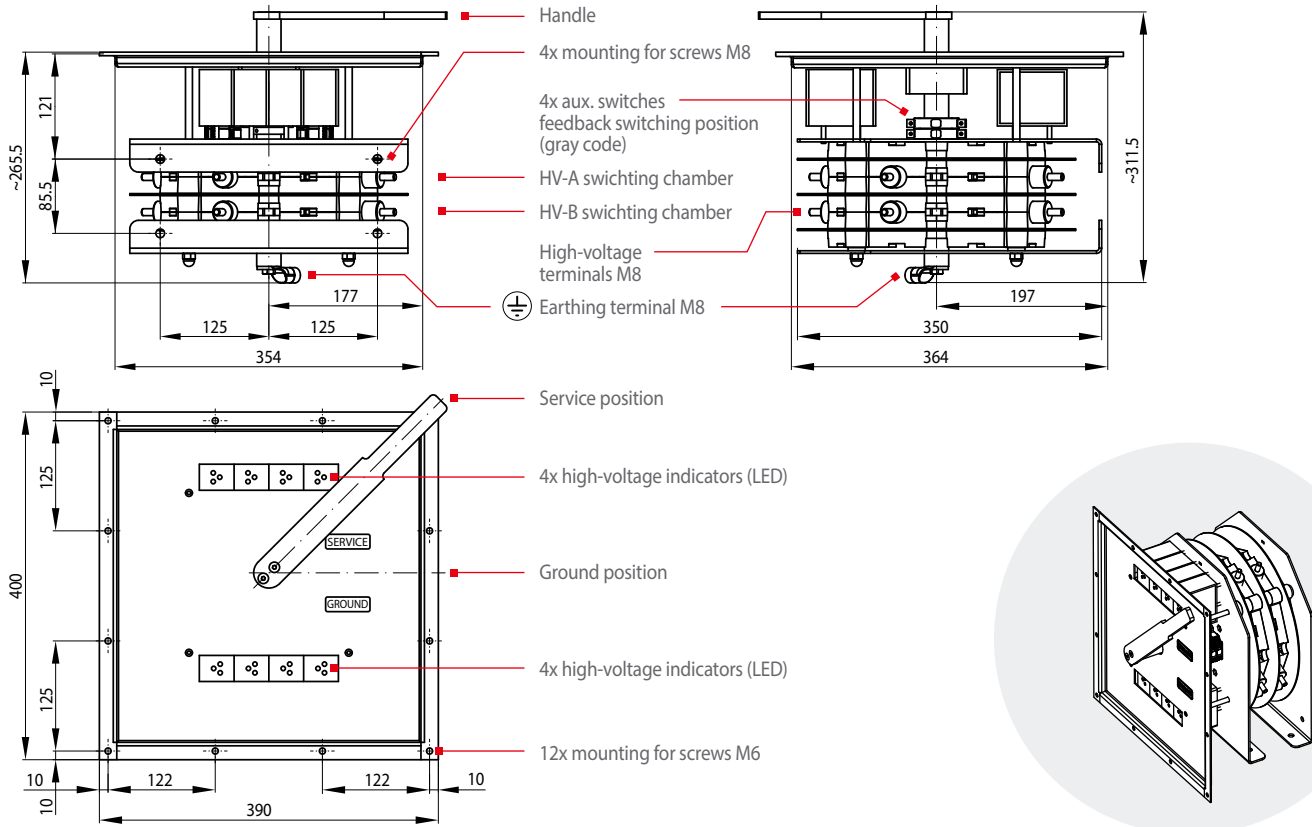

SD/SE/SDE/SCO 03 MG xxx xx Dimension diagram

SD, SE, SDE, SCO series

- Switchgear with 3 HV switching chambers and motor gear unit

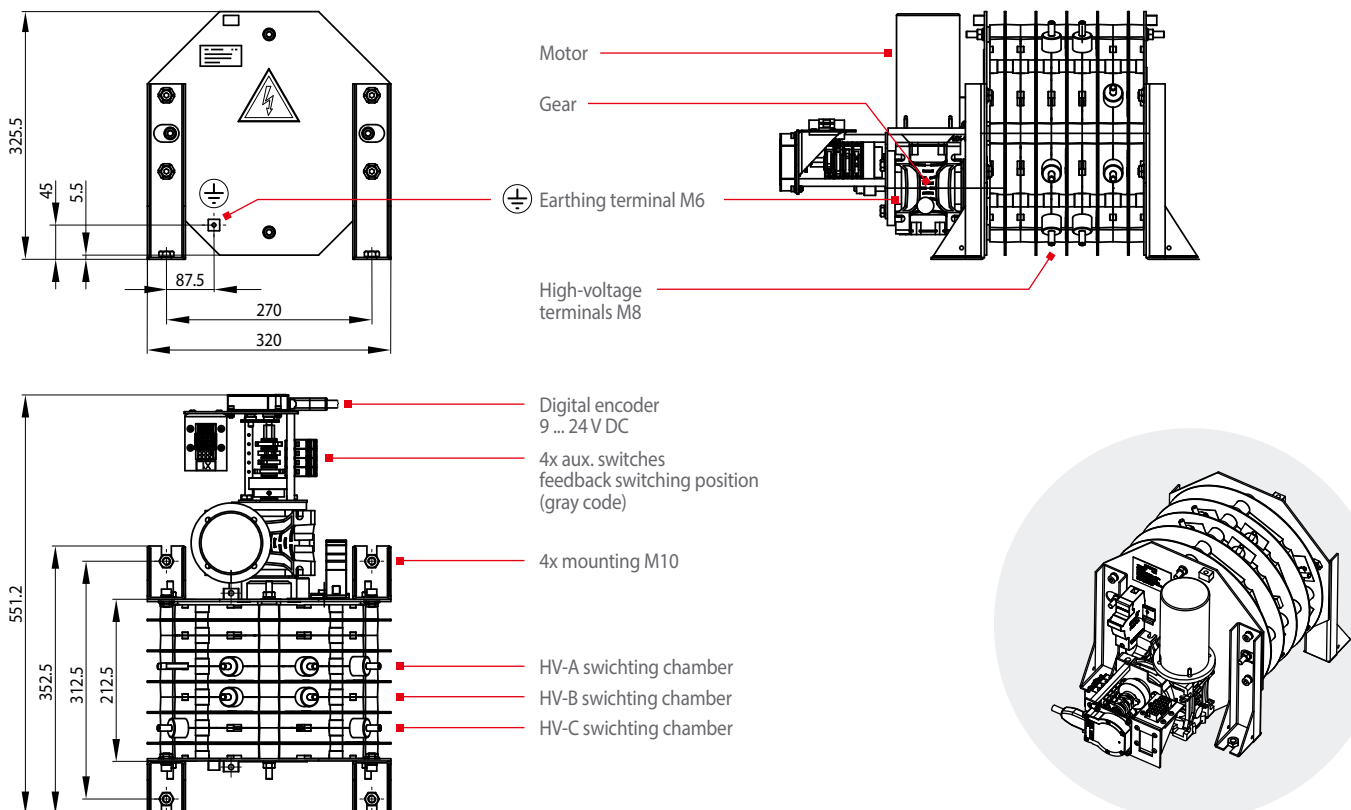

SD/SE/SDE/SCO 03 ML xxx xx Dimension diagram SD, SE, SDE, SCO series

• Switchgear with 3 HV switching chambers and linear motor unit

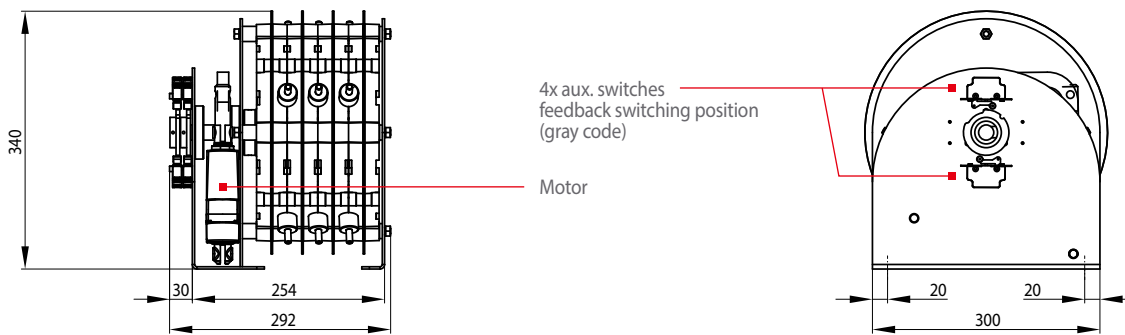
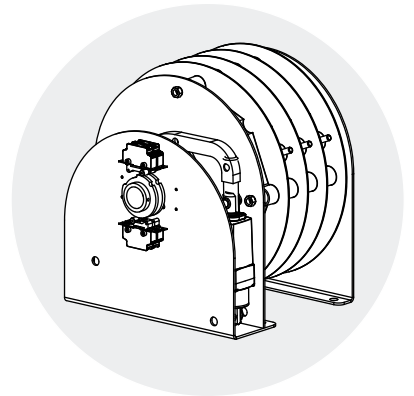
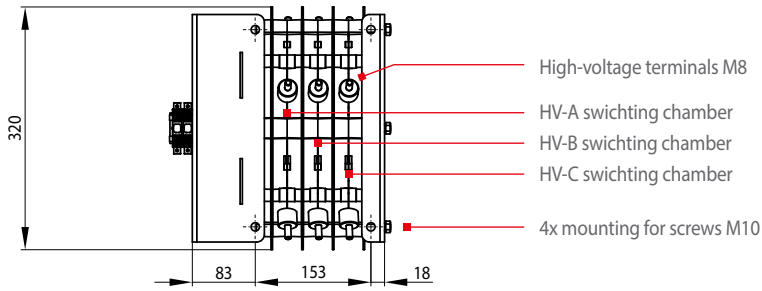

SD/SE/SDE/SCO 03 MA xxx xx Dimension diagram SD, SE, SDE, SCO series

• Switchgear with 1 HV switching chamber, manual actuation and 2 key switches

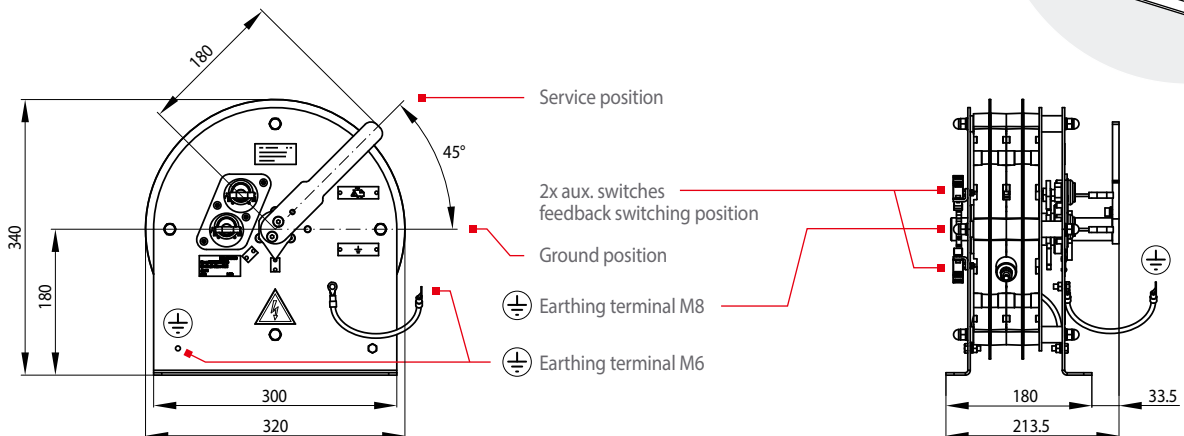
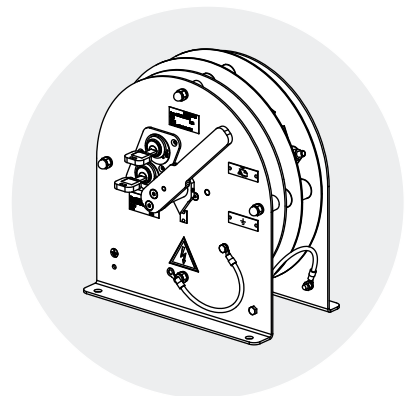
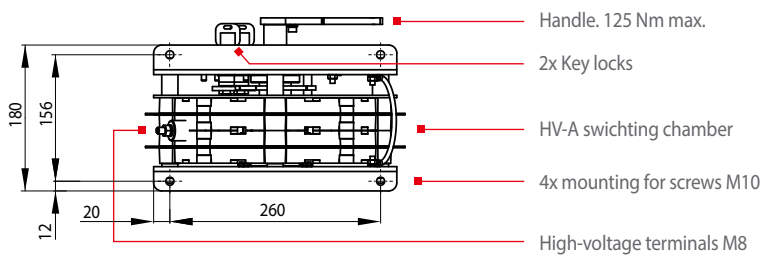

SE 03 MA xxx xx Dimension diagram

SE series

- Switchgear with 3 HV switching chambers, manual actuation and 5 times key multiplier

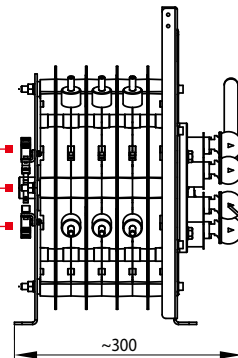
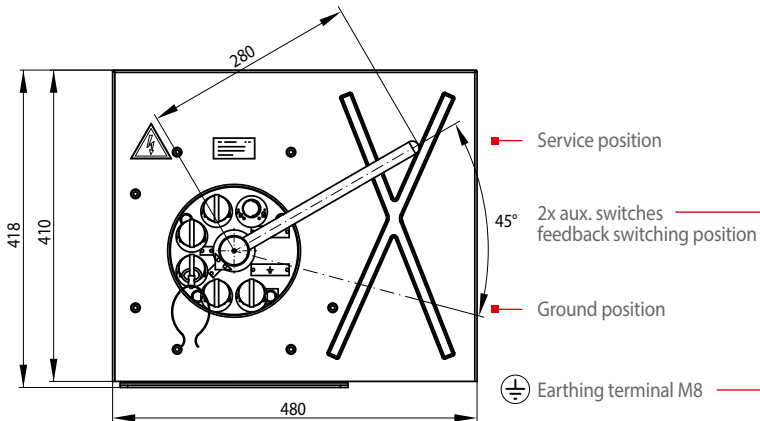
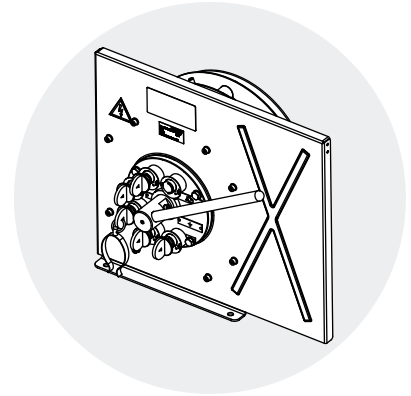
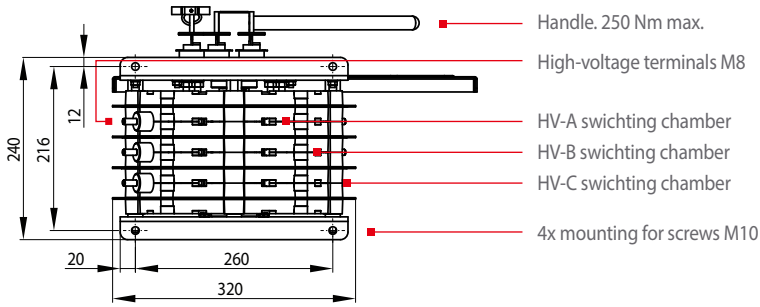

SE 01 MA xxx xx Dimension diagram

SE series

- Switchgear with 1 HV switching chambers, manual actuation

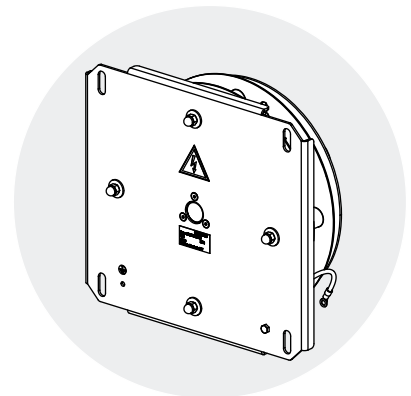
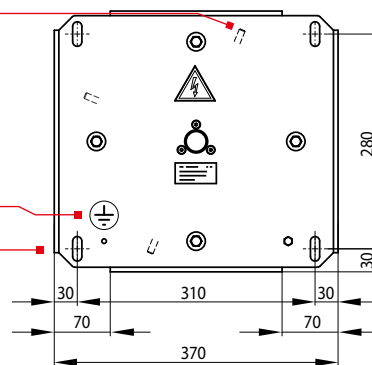
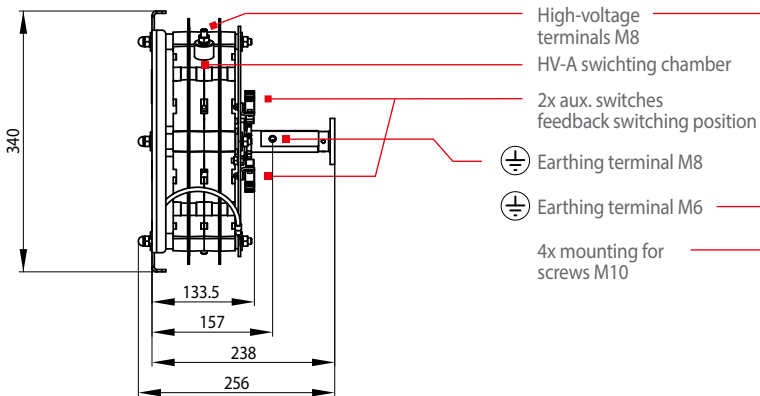

Mounting instructions, start up

SD, SE, SDE, SCO series

Dimensioning instructions

- For connection of the main contacts with a thermal current of 400 A Schaltbau recommends the use of bus bars or wires with the following dimensioning:
 - Cable cross-section $> 200 \text{ mm}^2$ or
 - bus bars with $25 \times 8 \text{ mm}$
- Multipole disconnectors with function of earthing switch: Schaltbau recommends a cross-section of 50 mm^2 min.
- For earthing of the housing Schaltbau recommends a green-yellow or transparent PE-wire with a minimal cable cross-section of 10 mm^2
- The minimum distances to voltage-carrying parts must be observed! The dimension drawings are provided for this purpose. Please refer to our operating manuals.
- Weight of different variants depends on the number of switching chambers – each chamber more/less means higher/lower weight of approx. 3 kg.
- Depth of different variants depends on the number of switching chambers – each chamber more/less means a higher/lower depth of 40 mm.
- Do you need some help? For selecting the disconnector, earthing switch, change-over-switch that suits your application best do not hesitate to ask our advice.

Mounting position

- Horizontal and vertical installation are allowed!

Start up

Before start up make sure that:

- The switch is properly secured to the chassis of car (check if screws are fixed)
- HV wires are properly connected at HV-contacts/terminals
- Low voltage wires are properly connected
- Earthing wires are properly connected to housing of device



Before energize the HV system, check if configuration of HV-contacts and blades accords with HV electrical schema. Use a multimeter!

Maintenance instructions

Safety instructions

SD, SE, SDE, SCO series



For detailed maintenance, safety and mounting instructions please refer to our operating manuals!



Defective parts must be replaced immediately!

- Do not exceed the current value stated in data sheet
- Do not operate any handling under electrical load
- Before maintenance operation ensure that the devices is completely deenergized
- Use only original spare parts

Schaltbau GmbH

For detailed information on our products and services visit our website – or give us a call!

Schaltbau GmbH
Hollerithstrasse 5
81829 Munich
Germany



Phone +49 89 9 30 05-0
Fax +49 89 9 30 05-350
Internet www.schaltbau-gmbh.com
e-Mail contact@schaltbau.de

with compliments:



Schaltbau GmbH manufactures in compliance with RoHS.



The production facilities of Schaltbau GmbH have been IRIS certified since 2008.



Certified to DIN EN ISO 14001 since 2002. For the most recent certificate visit our website.



Certified to DIN EN ISO 9001 since 1994. For the most recent certificate visit our website.

Electrical Components and Systems for Railway Engineering and Industrial Applications

Connectors

- Connectors manufactured to industry standards
- Connectors to suit the special requirements of communications engineering (MIL connectors)
- Charging connectors for battery-powered machines and systems
- Connectors for railway engineering, including UIC connectors
- Special connectors to suit customer requirements

Snap-action switches

- Snap-action switches with positive opening operation
- Snap-action switches with self-cleaning contacts
- Enabling switches
- Special switches to suit customer requirements

Contactors

- Single and multi-pole DC contactors
- High-voltage AC/DC contactors
- Contactors for battery powered vehicles and power supplies
- Contactors for railway applications
- Terminal bolts and fuse holders
- DC emergency disconnect switches
- Special contactors to suit customer requirements

Electrics for rolling stock

- Equipment for driver's cab
- Equipment for passenger use
- High-voltage switchgear
- High-voltage heaters
- High-voltage roof equipment
- Equipment for electric brakes
- Design and engineering of train electrics to customer requirements

We reserve the right to make technical alterations without prior notice.

For updated product information visit www.schaltbau-gmbh.com.
Issued 01-2018