

4

Electrics for Rolling Stock

**FRE-CRVIO, FRE-AVTRA,
FRM-ASR, FRF-M7 series**

Footrests for rail vehicles

S293, ZL290, S579 series

DSD push buttons and foot switches
for rail vehicles

Catalogue F290.en

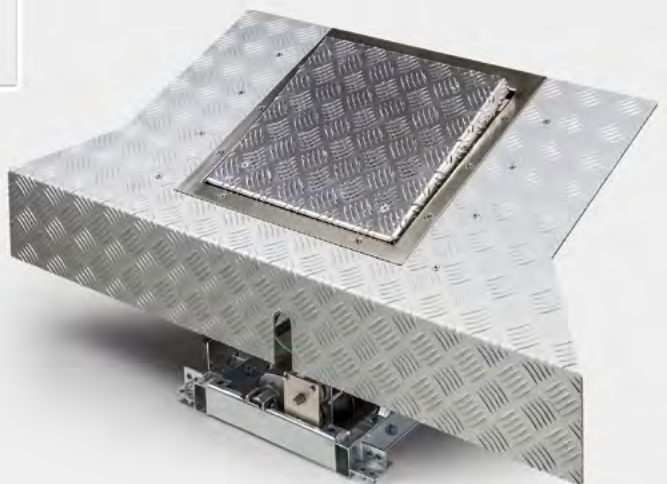
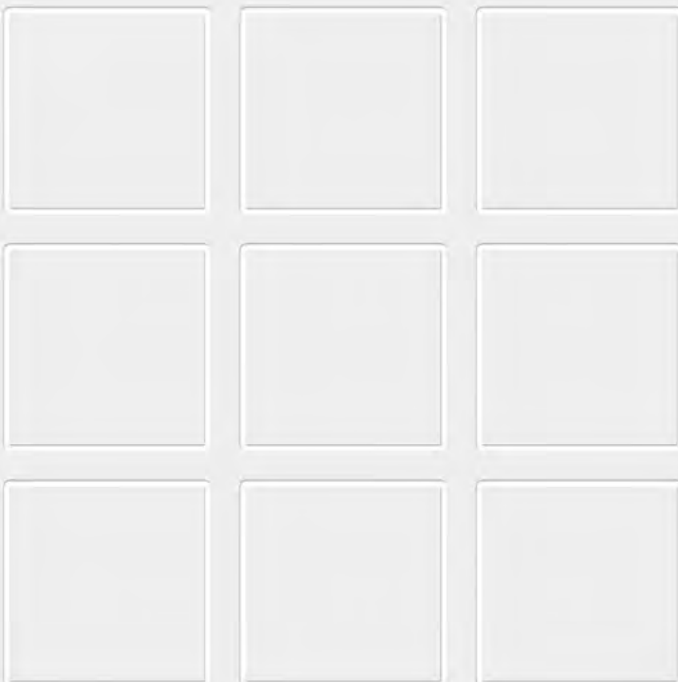

More information here:
schaltbau-gmbh.com

Footrests, DSD push buttons and DSD foot switches

Rail vehicles in good hands – with footrests, DSD foot switches and DSD push buttons

Footrests with DSD switches allow the driver to operate the driver safety device from an ergonomic seating position while keeping hands free. Additional functions, e.g. for track sanding or horn activation can be integrated. An optional heatable base plate provides additional comfort in winter. Footrests and DSD switches can be found in railway vehicles all around the world. They operate with the utmost safety, reliability, longevity and low maintenance. The quality system for development, manufacturing and

assembly in our factory is DIN EN ISO 9001 and IRIS (International Railway Industry Standard) compliant. The long term pay-off is the long term in low follow-up costs for service and maintenance and, of course, a high degree of safety over the vehicle's many years of operation. The design of our robust, shockproof and vibration-proof footrests enables a great variety of possible variants.

Customized solutions

In cooperation with you, our experienced design engineers select appropriate solutions from the existing basic models and customize them to meet your needs.

Together, we find the optimum, state-of-the-art solution for every requirement. Our inhouse electronics development division enables us to respond quickly and flexibly to changing needs. Comprehensive type testing is performed in our laboratory according to customer specifications.

Generally, footrests are customized product developments because of the need for adaptations.

Modern project management ensures adherence to the required deadlines and quality – even when requirements change.

Talk to us and set us a challenge.

Globally leading



Design to order

Based on many years' experience, we develop new footrests in close cooperation with the customer dependent on their requirements and exact specifications.

The footrests are then manufactured by Schaltbau in their own works. Schaltbau assists the customer with the specifications and supplies complete documentation.

Our Portfolio

- Complete in-house customized design and manufacture
- Integrated DSD foot switch, additional foot switches on request
- Reliable, rugged, maintenance-free
- Standard-compliant design and components

Footrests
DSD switches

**Customized, modular, robust, maintenance-free –
Ergonomic design for more safety**

The modular construction of our robust, shock and vibration-proof footrests provides vibration options in the design and arrangement of additional switching elements.

The devices meet all requirements of the locomotive manufacturers and are notable for their solid construction and high reliability.



S579 TG
DSD push button, panel mounting,
actuator colour yellow
1x snap-action switch



S579 T
DSD push button, panel mounting,
actuator colour black
1x snap-action switch



S579 W, S579 WR
DSD push button, wall mounting,
1x snap-action switch
S579 W actuator colour black
S579 WR actuator colour red



S293 S1 / S293 S1A
DSD foot switch with standard plate,
S293 S1 1x snap-action switch
S293 S2 2x snap-action switches

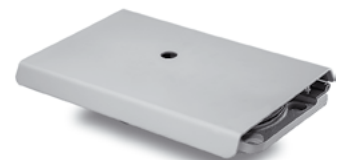

ZL290 B
DSD foot switch with standard plate,
1x snap-action switch with
stronger reset spring

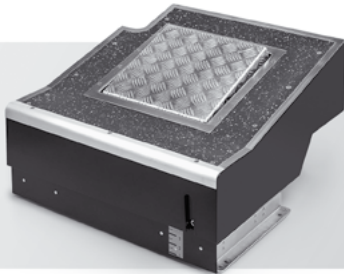

ZL290 B2
DSD foot switch with longer plate and
tactile edge, 1x snap-action switch with
stronger reset spring

Series overview

Footrest FRE-AVTRA

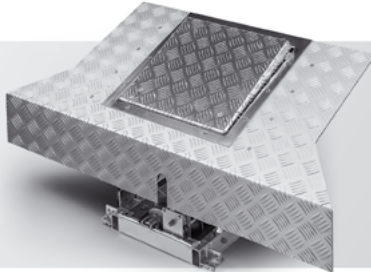
- Electrically adjustable footrest
- Height adjustment simply by pressing a button
- Height 206.5 mm min., stroke 150 mm max.

Footrest FRE-CRVIO

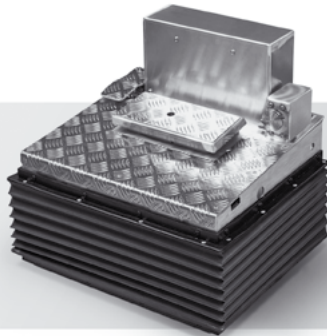
- Electrically adjustable footrest
- Height adjustment simply by pressing a button
- Height 170 mm min., stroke 120 mm max.

Footrest FRM-ASR

- Mechanically adjustable footrest
- Height adjustment simply by pressing a pedal
- Height 125 mm min., stroke 150 mm max.

Footrest FRF-M7

- Footrest without height adjustment
- Height 220 mm min.
- Heatable base plate, optional

FRE-AVTRA, FRE-CRVIO, FRM-ASR, FRF-M7 Footrests for driver's cabs in railway vehicles

The mechanically or electrically adjustable footrests can be easily positioned at the desired height just by pressing a pedal or a button. A rugged DSD foot switch is included. Additional functions, e.g. track sanding and/or horn are available on request. The base plate with heating option provides additional comfort in winter.

The devices meet all the requirements of the rail vehicle manufacturers and are notable for their solid construction and high reliability.

Features, applications, variants

Features:

- Modular, rugged, maintenance-free
- Customized design with or without height adjustment
- Integrated DSD foot switch
- Optional additional foot switches
- Optional heatable base plate
- High vibration and shock resistance

Applications:

- Driver's cabs of locomotives and multiple units
- Driver's cabs of trams

Variants (selection):

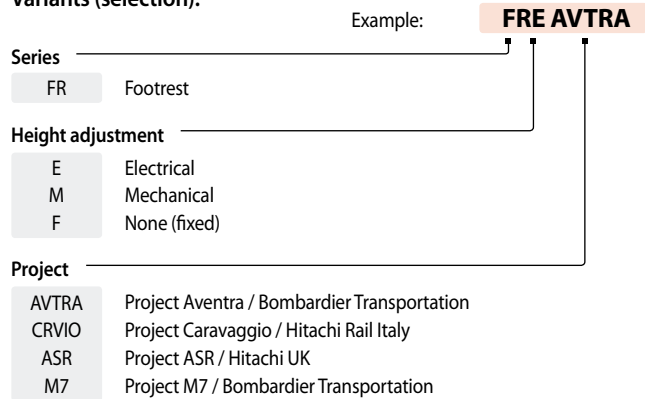

This catalogue shows only stock items. If you need a special variant, please do not hesitate to contact us! Maybe the type of footrest you are looking for is among our special designs. If not, we can also supply customized designs. In this case, however, minimum ordering quantities apply.

Specifications

	FRE-AVTRA	FRE-CRVIO	FRM-ASR	FRF-M7
Height adjustment	Electric actuator* Scissors lift / spindle drive	Electric actuator* Scissors lift / spindle drive	Mechanical actuator gas spring	---
Power supply	24 / 72 / 110 V DC	24 / 72 / 110 V DC	---	---
DSD foot switch Design Mechanical endurance	S293, ZL290, s. a. page 8 ... 11 or other series on request > 10 million operating cycles			
Additional foot switches (optional) Design Mechanical endurance	optional / on request 1 ... 2x S847 or other series on request > 10 million operating cycles			
Mechanical endurance	20,000 operations	20,000 operations	---	---
IP rating EN 60529	IP66, all electric components	IP66, all electric components	IP67, foot switch IP54, DSD foot switch	IP54, DSD foot switch
Insulation EN 50124-1	•	•	•	•
Housing, material Base plate, with anti-sliding cover Heatable base plate, optional Lower part	Aluminium, steel, rubber • Aluminium, steel	Aluminium, steel • Aluminium, steel	Aluminium, steel • Aluminium, steel	Aluminium, steel • Aluminium, steel
Mounting position	horizontal	horizontal	horizontal	horizontal
Weight	~40 kg	~35 kg	~20 kg	~18 kg
Temperature range	-50° C ... +70° C	-50° C ... +70° C	-50° C ... +70° C	-50° C ... +70° C
Standards: General Fire/smoke Shock/vibration	EN 60077, EN 12663, EN 15085, EN 50121 EN 45545, BS6853 EN 61373, UIC 651			

* Manual override in case of a system failure

FRE-AVTRA Electrical adjustable footrest for railway vehicles

Dimension diagram:

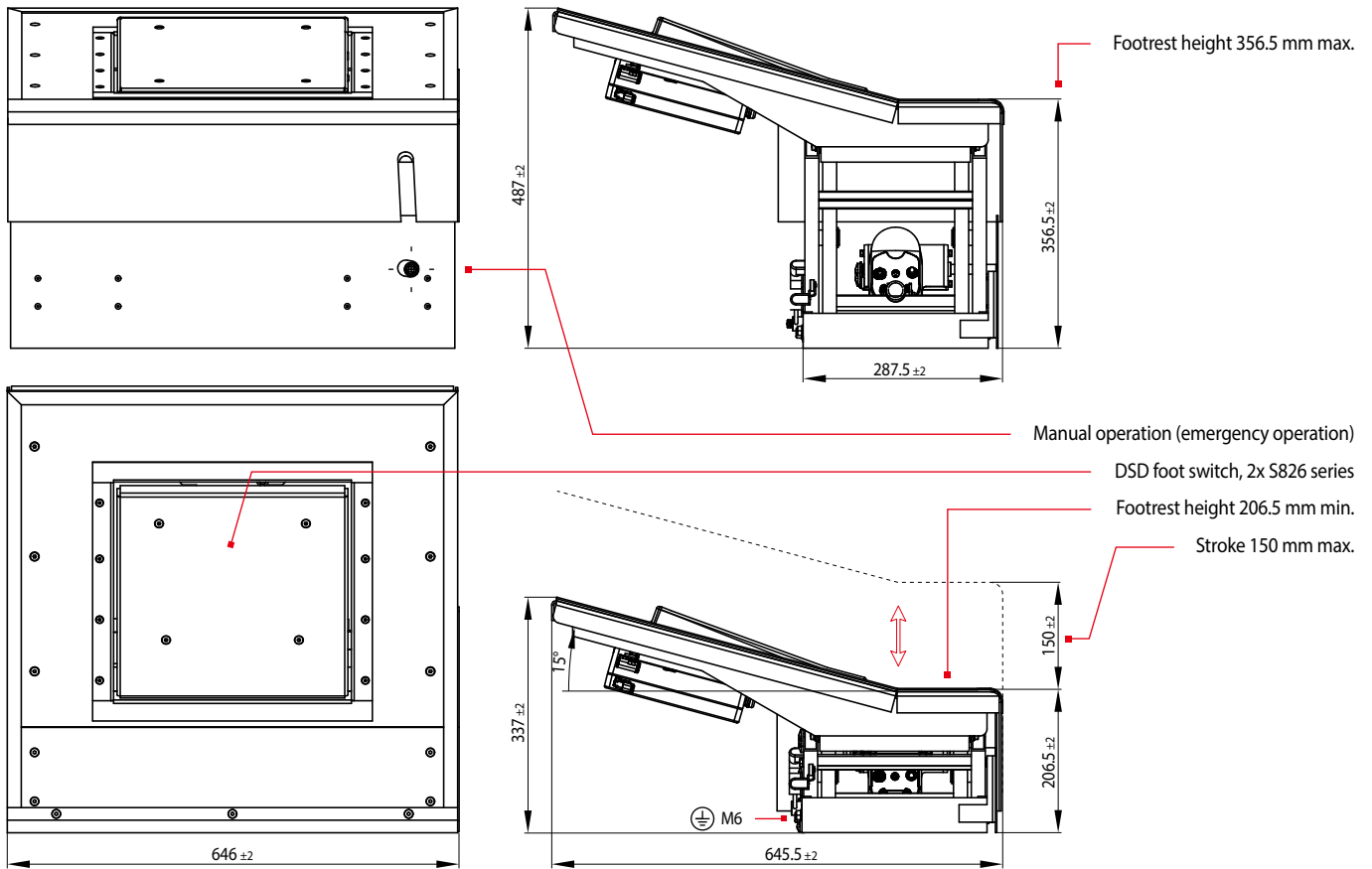

FRE-CRVIO Electrical adjustable footrest for railway vehicles

Dimension diagram:

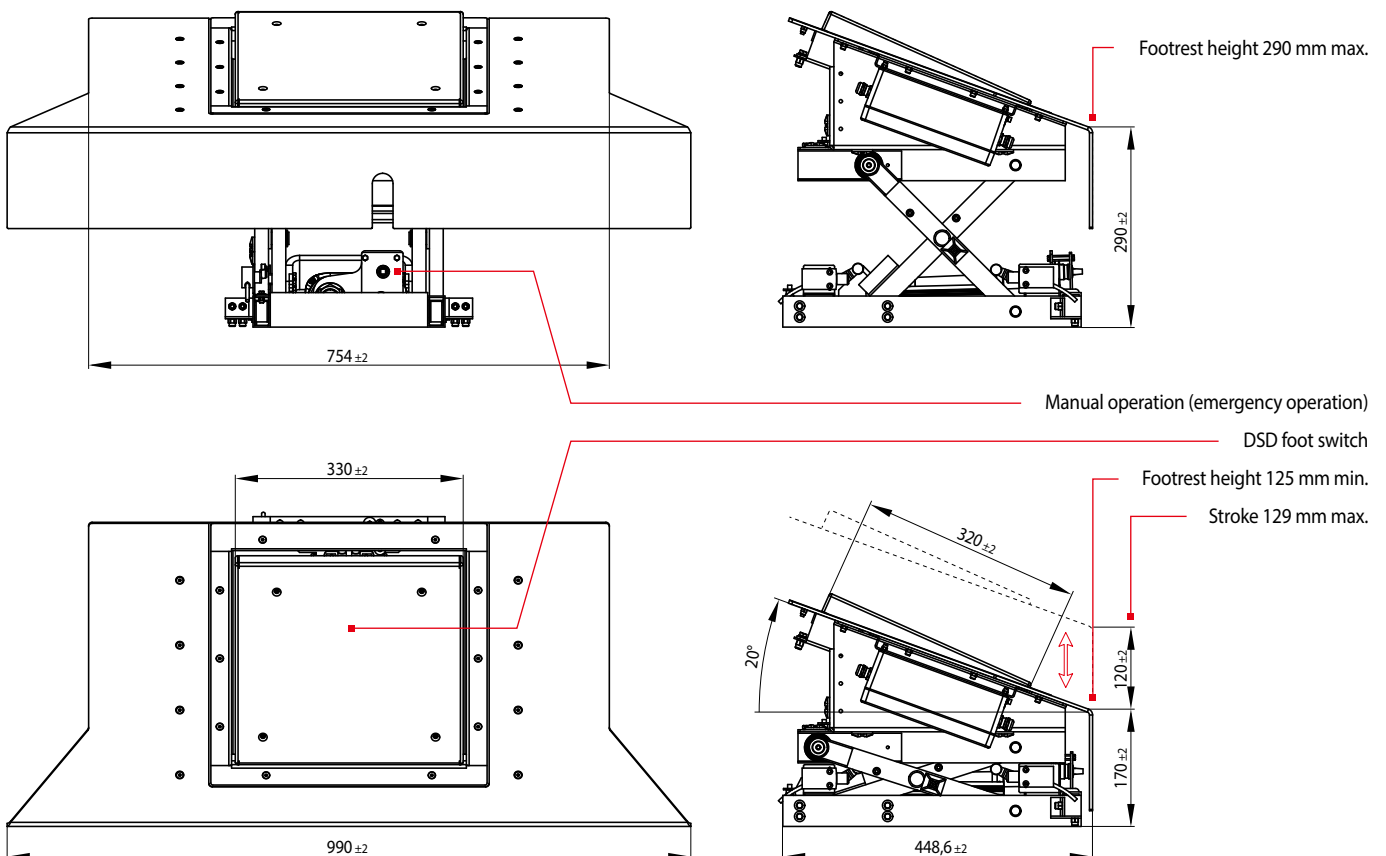

FRM-ASR Mechanical adjustable footrest for railway vehicles

Dimension diagram::

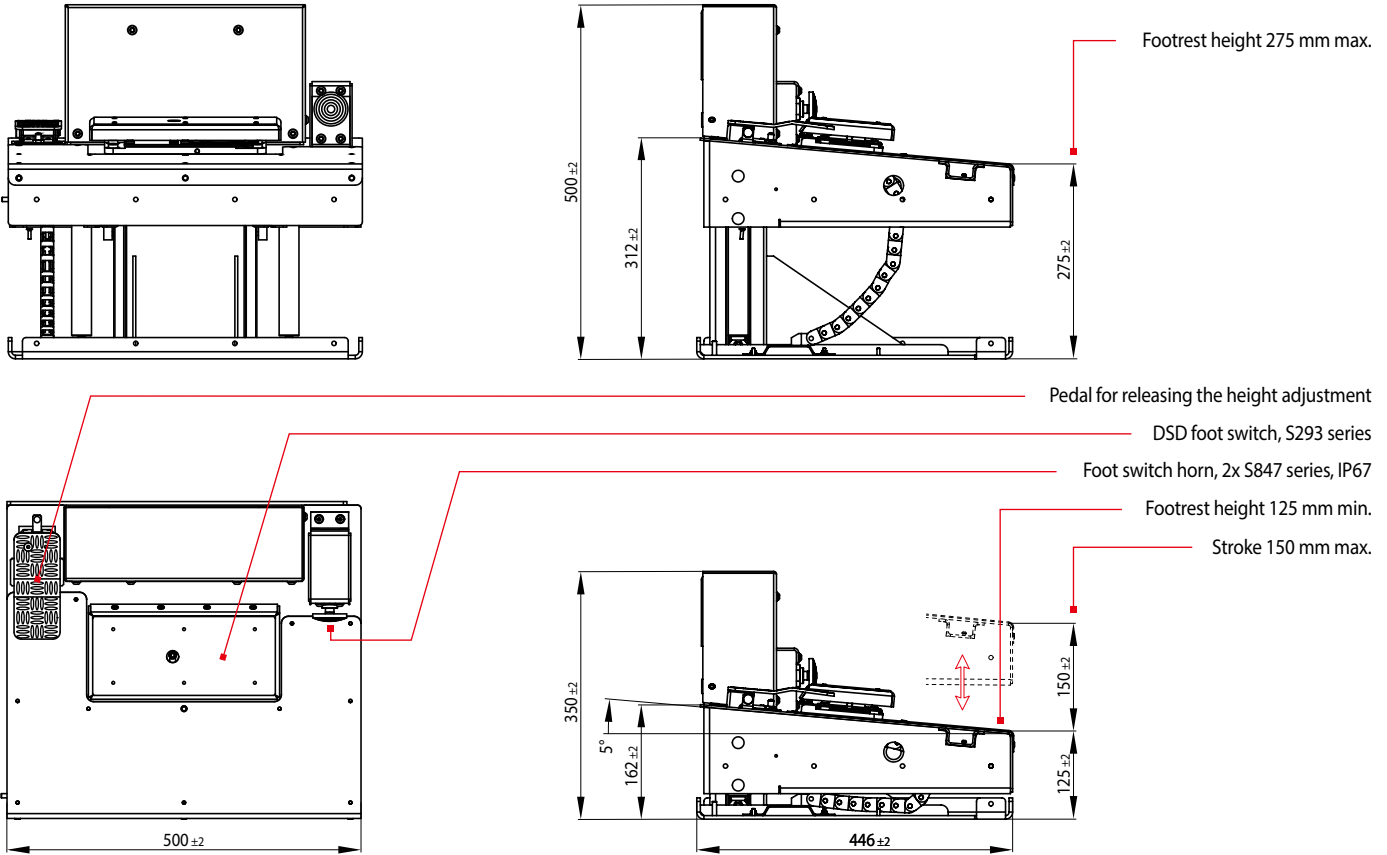

FRF-M7 Footrest for railway applications without height adjustment

Dimension diagram::

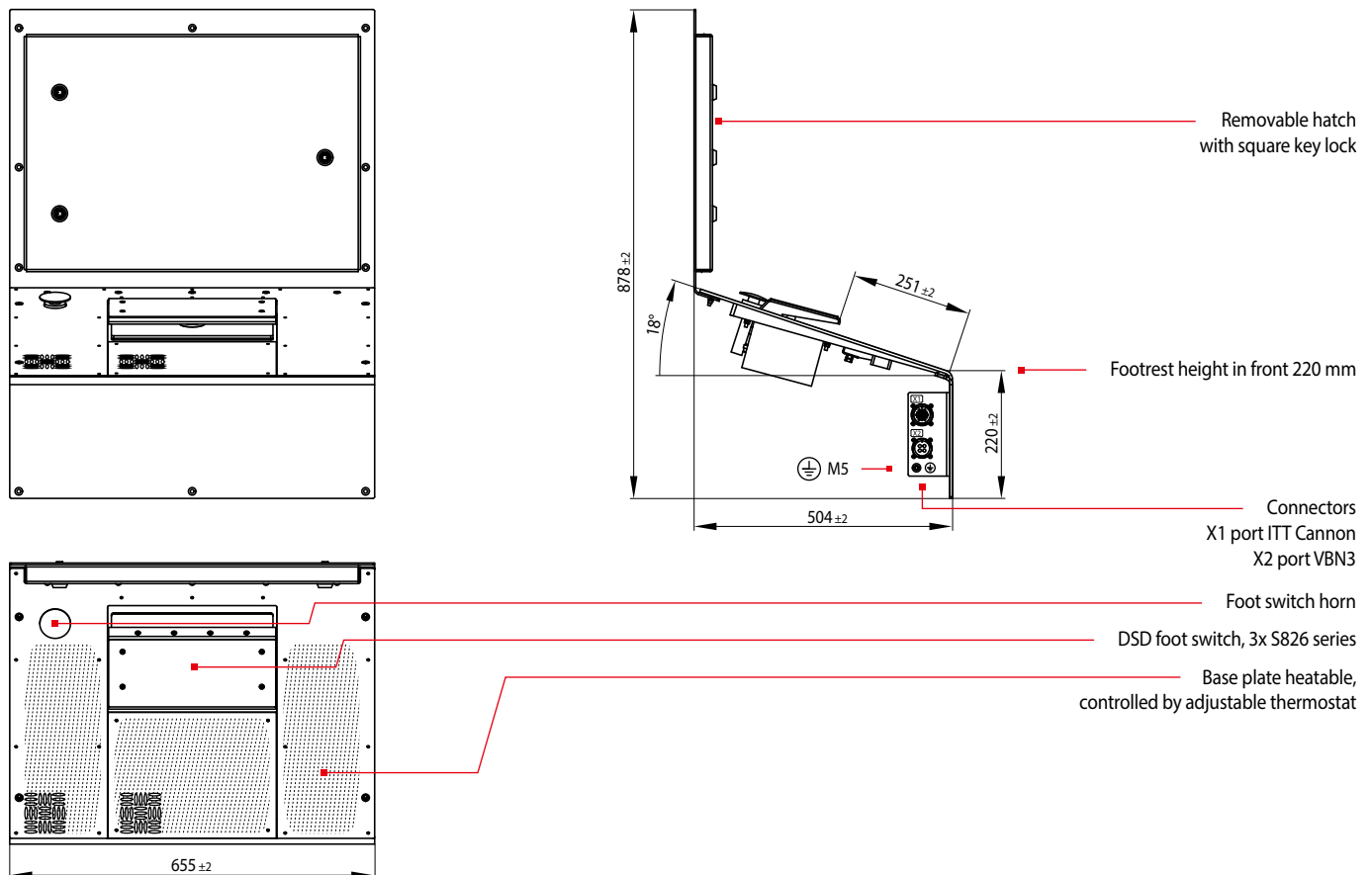

S579 DSD push buttons for railway vehicles

Driver safety device (DSD) push buttons S579 series are designed for use under rough operating conditions, e.g. on locomotives and multiple units.

The devices meet all the requirements of the rail vehicle manufacturers, and are notable for their solid construction and high reliability.

Features:

- Reliable, rugged, maintenance-free
- Snap-action switches S804 or S814 with reinforced return spring, S814 featuring wiping, self-cleaning double-break contacts
- High electrical rating due to solid contact bridge
- Contact material: silver or gold-plated silver
- High resistance to shock and vibration

Applications:

- Driver's cabs of locomotives and multiple units
- Driver's cabs of trams

Variants:

- **S579 T** Panel mounting, actuator colour black, 1x snap-action switch S804 b40
- **S579 TG** Same as S579 T, but with yellow button
- **S579 W** Wall mounting, actuator colour black, 1x snap-action switch S814 b 40
- **S579 WR** Same as S579 W, but with red button

Specifications		S579
Switching element	S579 T, S579 TG S579 W, S579 WR	S804 b40 with reinforced return spring * S814 b 40 with reinforced return spring *
Contact configuration		Form Za SPDT-DB switch with silver contacts **, rigid contact bridge; self-cleaning contacts (S804 b40 only)
Terminals	Switching element Protection earth	M3 screws with saddle clamp ⊕ M5 screw
Conv. thermal current I_{th}		10 A
Rated insulation voltage U_i		250 V
Rated imp. withstand voltage U_{imp}		2.5 kV
Pollution degree		PD3
Actuator travel		~ 3.6 mm
Mechanical endurance		> 5 million operating cycles
IP rating	EN 60529	IP66
Insulation	EN 50124-1	•
Material	Actuator Colour Housing / Colour	Phenolic resin moulding compound PF31 S579 T, ...W: black, S579 TG: yellow, S579 WR: red For details see dimension diagramm
Mounting position		any
Weight		S579 T, ... TG: ~ 500 g / S579 W, ... WR: ~ 610 g
Temperature range		-40° C ... +85° C
Standards:	General Fire/smoke Shock/vibration	EN 60077, VDE0660 EN 45545 EN 61373, IEC 651

* For more information see [D20 catalogue](#) ** Gold upon request

S579 T, S579 TG, S579 W, S579 WR SDSD push buttons for panel or wall mounting

Dimension diagram: S579 T, S579 TG:

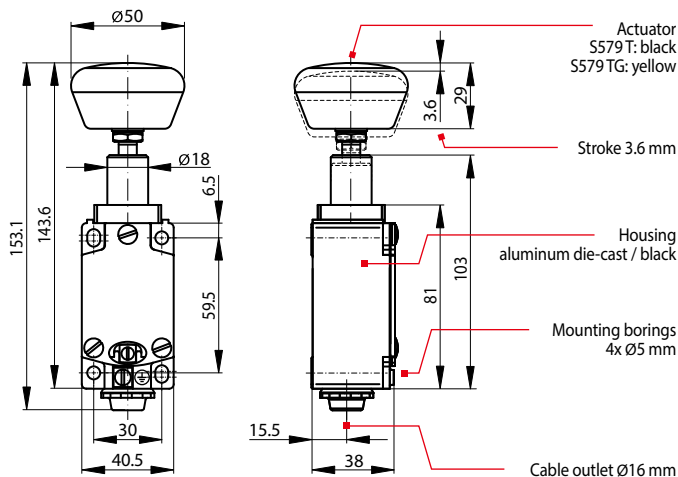

Dimension diagram: S579 W, S579 WR:

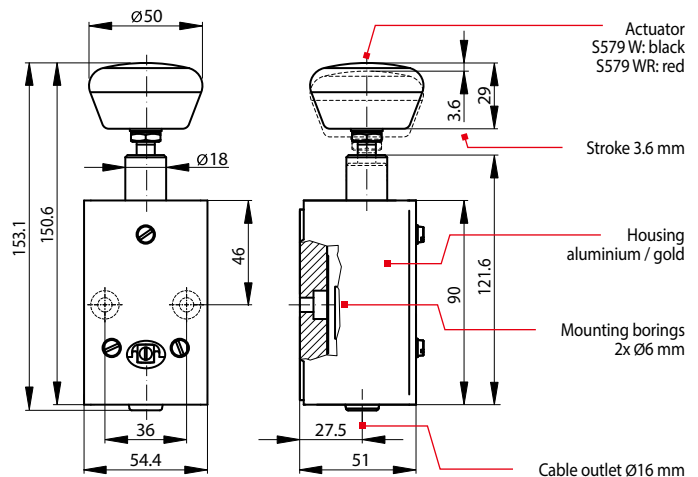

Circuit diagram:

S579 T, S579 TG series
1x S804 b40

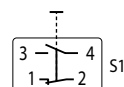

Circuit diagram:

S579 W, S579 WR series
1x S814 b40

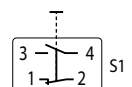

S293, ZL290 DSD foot switches for railway vehicles

Schaltbau S293 and ZL290 series driver safety device (DSD) foot switches are compact, reliable and have a long service life. The DSD foot switches are designed for use under rough operating conditions, e.g. on locomotives and multiple units.

The device meets all the requirements of the rail vehicle manufacturers and are notable for their solid construction and high reliability.

Features, applications, variants

Features:

- Long mechanical life: reliable, rugged, maintenance-free
- Long electrical life at e.g. 24 V DC / 10 mA
- Snap-action switches S804, S814 or S814 with reinforced return spring and self-cleaning contacts
- Contact material: silver or gold-plated silver
- High resistance to shock and vibration
- Stainless steel case, ZL290 only: resistant to oil, maritime climate, ozone and UV radiation

Applications:

- Driver's cabs of locomotives and multiple units
- Driver's cabs of trams

Variants:

- **S293 S1** DSD foot switch with standard plate (240 x 124 mm), 1x Snap-action switch
- **S293 S1A** DSD foot switch with standard plate (240 x 124 mm), 2x Snap-action switches
- **S293 S2** DSD foot switch with wider plate (240 x 154 mm), 1x Snap-action switch
- **S293 S4** DSD foot switch with longer plate (400 x 124 mm), 1x Snap-action switch
- **ZL290 B** DSD foot switch with standard plate (234 x 141 mm), 1x Snap-action switch with reinforced return spring
- **ZL290 B1** DSD foot switch with longer plate (299 x 144 mm), 1x Snap-action switch with reinforced return spring
- **ZL290 B2** DSD foot switch with longer plate and tactile edge (296 x 129 mm), 1x Snap-action switch with reinforced return spring

Specifications

		S293	ZL290
Switching element		S293 S1: 1x S814 b * S293 S1A: 2x S814 b * S293 S2: 1x S804 b40 with reinforced return spring * S293 S4: 1x S814 b *	ZL290 B: 1x S814 b40 with reinforced return spring * ZL290 B1: 1x S814 b40 with reinforced return spring * ZL290 B2: 1x S814 b40 with reinforced return spring *
Contact configuration		Form Za SPDT-DB switch with silver contacts*, rigid contact bridge; self-cleaning contacts (S804 b40 only)	
Anschlüsse	Schaltelement Schutzleiter ⊕ Cable assembled with connectors	M3 screws with saddle clamp ⊕ M5 screw Upon request	M3 screws with saddle clamp ⊕ M4 screw ZL290 B, ...B1: upon request / ZL290 B2: cable + connector
Conv. thermal current I _{th}			10 A
Rated insulation voltage U _i			250 V
Rated imp. withstand voltage U _{imp}			2.5 kV
Pollution degree			PD3
Actuator travel		~ 10 mm	~ 14 mm
Actuator force		S293 S1, ...S1A, ...S2: ~ 35 ±10 N / S293 S4: ~ 45 ±10 N	ZL290 B, ...B1, ...B2: ~ 33 N ±8 N
Mechanical endurance		> 10 million operating cycles	> 10 million operating cycles
IP rating	EN 60529	IP54	IP64
Insulation	EN 50124-1	•	•
Housing, material	Base plate / colour Lower part / colour	Sheet steel, RAL7001 / silver grey (RAL7001) Cast aluminium, RAL7001 / silver grey (RAL7001)	Stainless steel sheet X5 CrNi 189 / silver grey Stainless steel sheet X5 CrNi 189 / silver grey
Mounting position		horizontal	horizontal
Weight		S293 S1, ...S1A: 2.3 kg / S293 S2: 2.4 kg / S293 S4: 2.5 kg	ZL290 B: 2.1 kg / ZL290 B1: 2.5 kg / ZL290 B2: 2.6 kg
Temperature range		-40° C ... +85° C	-25° C ... +60° C
Standards:	General Fire/smoke Shock/vibration		EN 60077, VDE0660 EN 45545 EN 61373, IEC 6151

S293 S1 / S293 S1A DSD foot switch with standard plate (240 x 124 mm)

Dimension diagram:

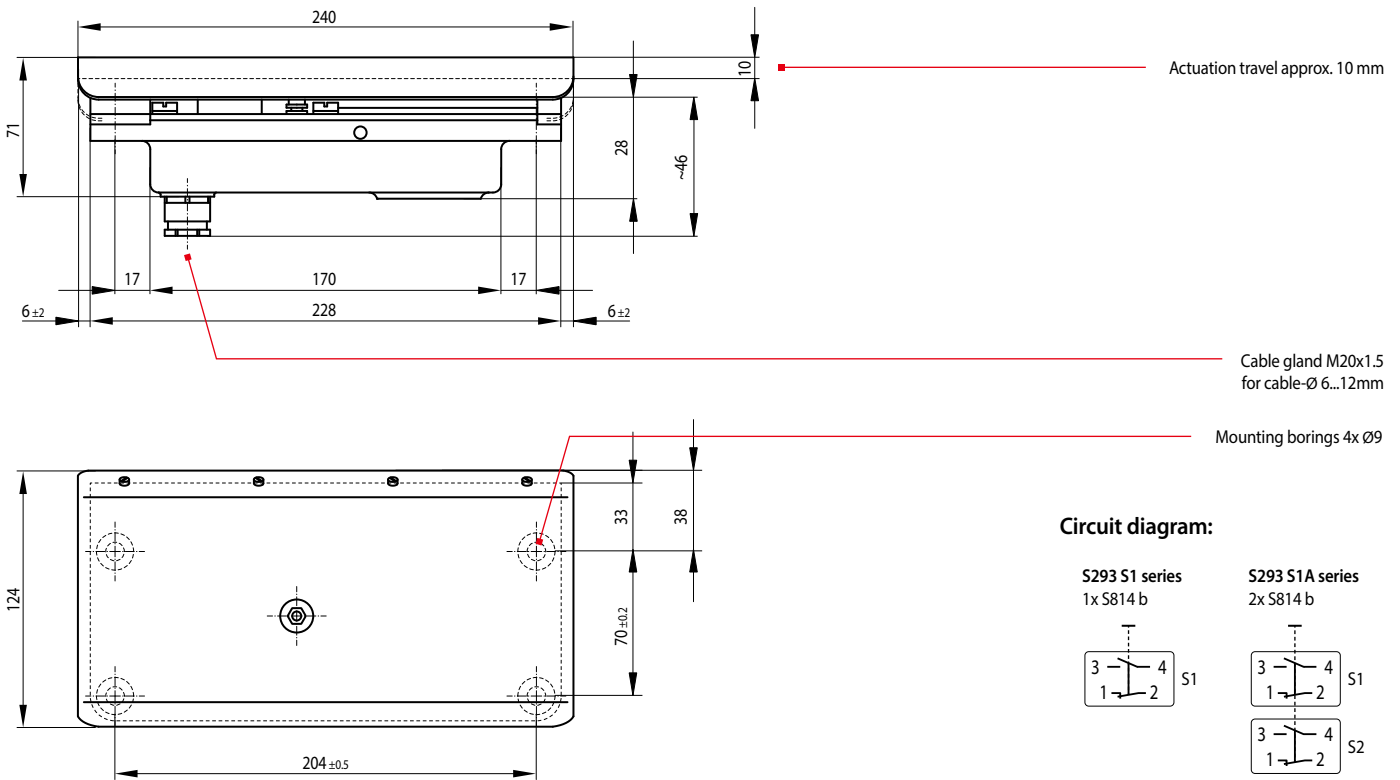

S293 S2 DSD foot switch with wider plate (240 x 154 mm)

Dimension diagram:

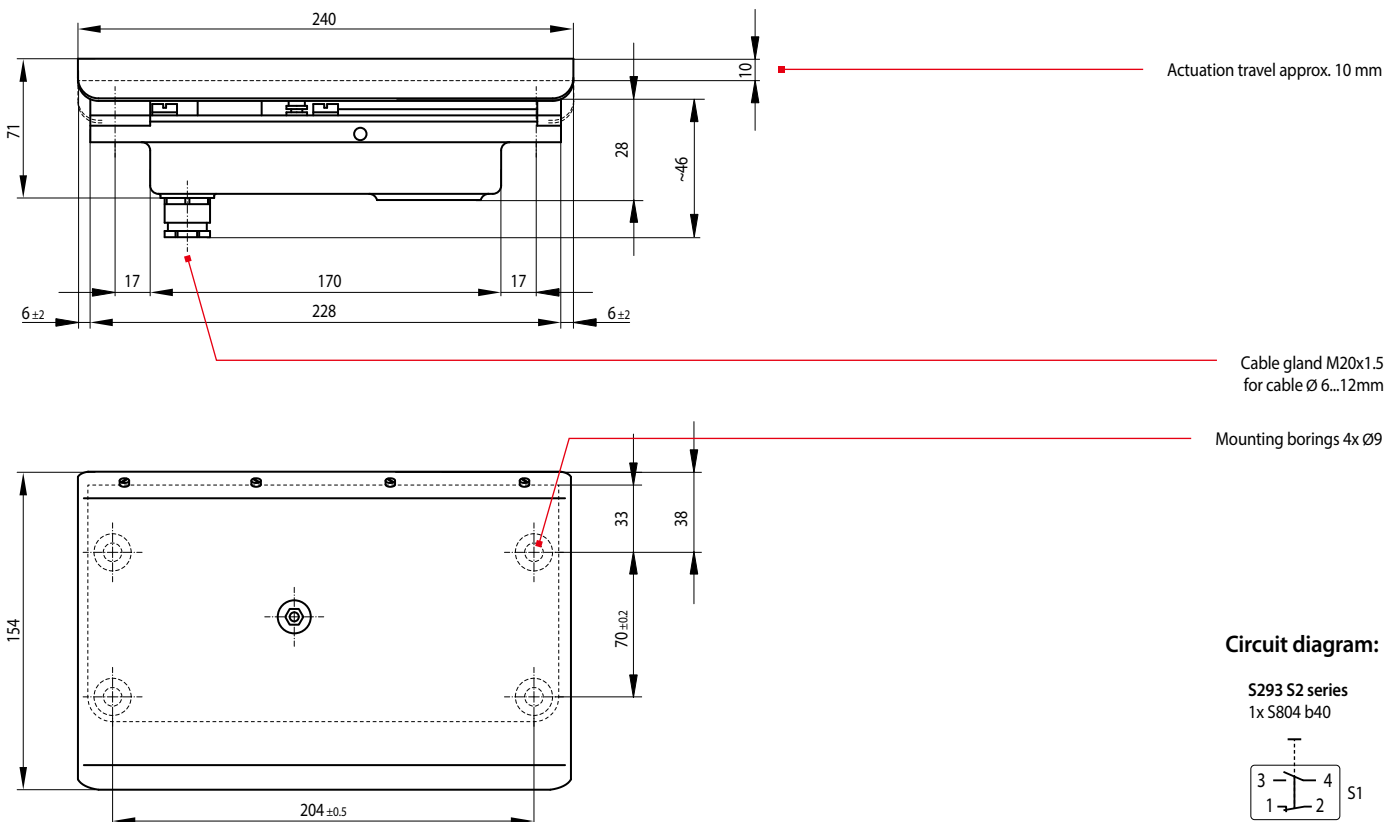

S293 S4 DSD foot switch with longer plate (400 x 124 mm)

Dimension diagram:

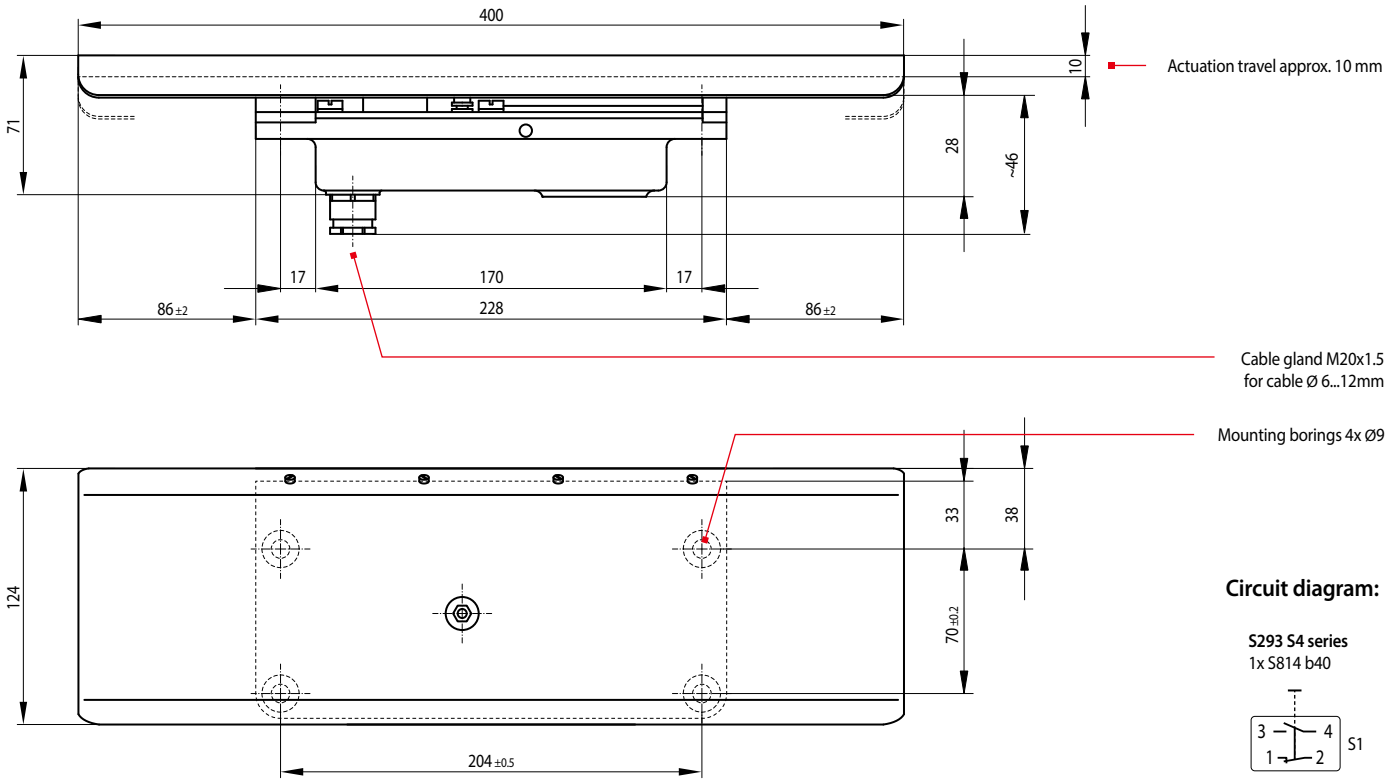

ZL290 B DSD foot switch with standard plate (234 x 141 mm)

Dimension diagram:

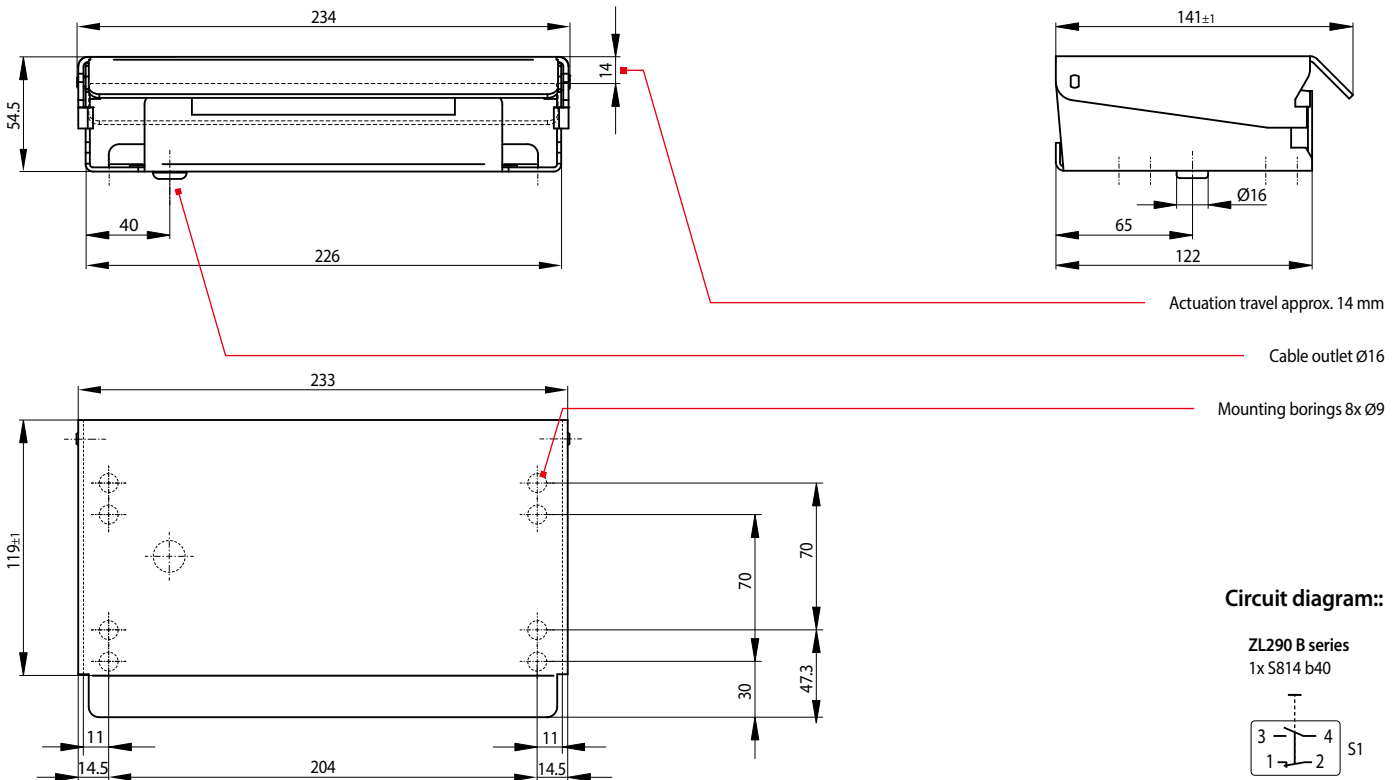

ZL290 B1 DSD foot switch with longer plate (299 x 144 mm)

Dimension diagram:

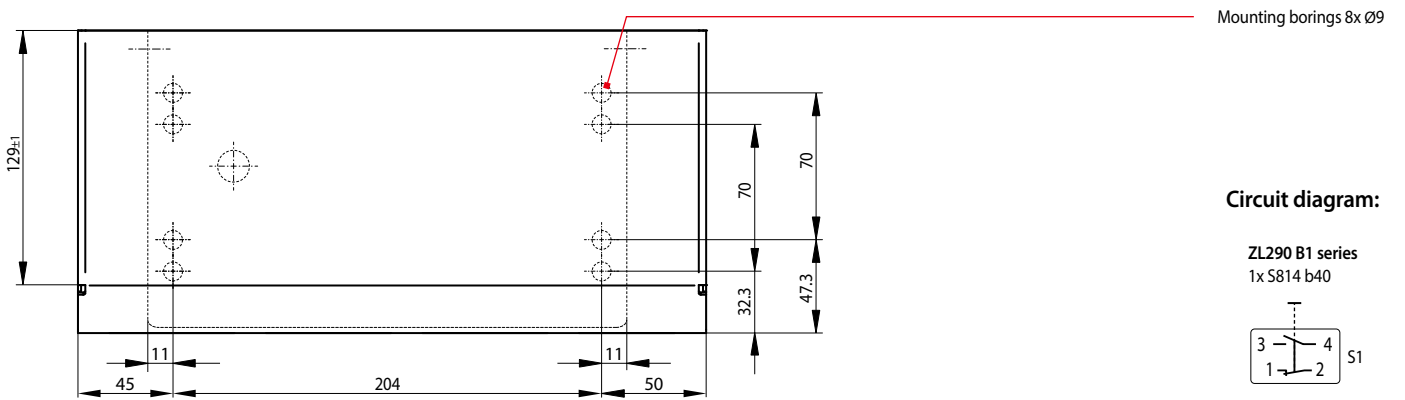
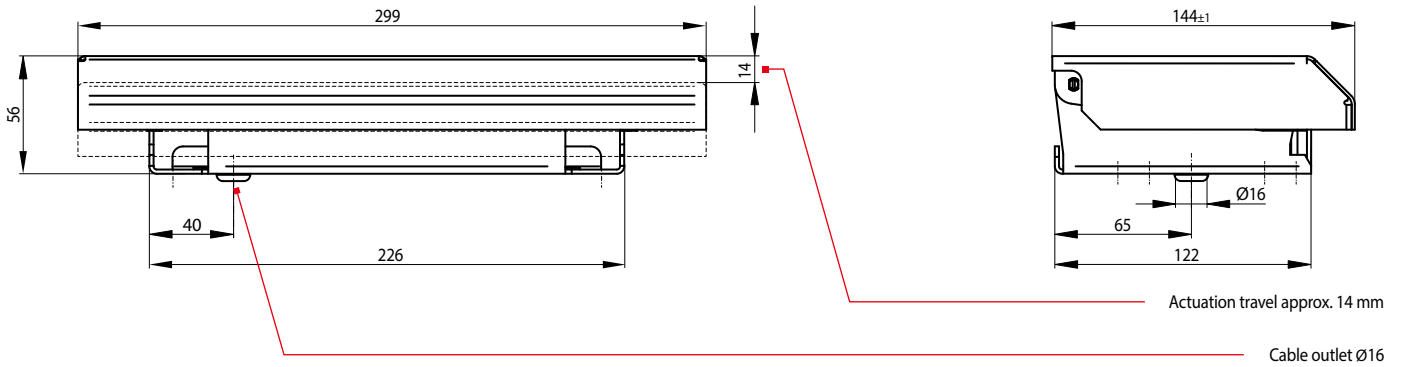

Circuit diagram:

ZL290 B1 series
1x S814 b40

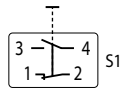

ZL290 B2 DSD foot switch with longer plate and tactile egde (296 x 129 mm)

Dimension diagram:

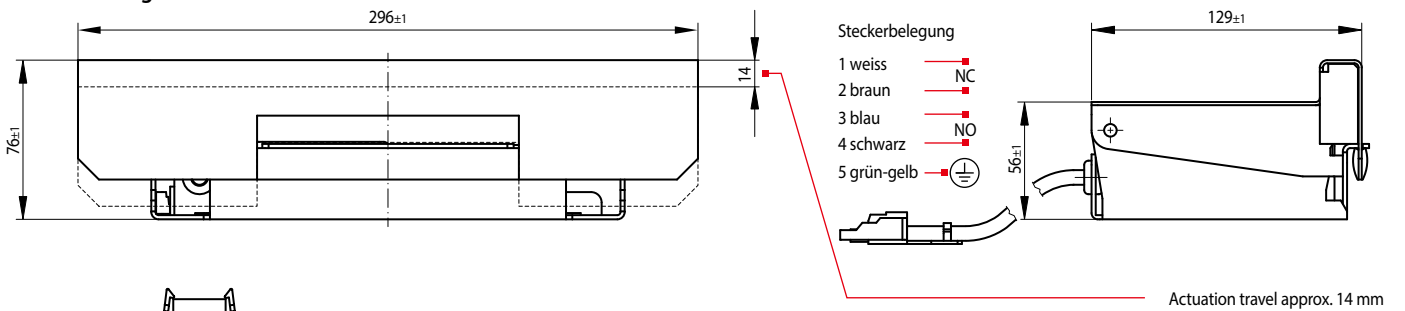

Steckerbelegung

- 1 weiss — NC
- 2 braun — NC
- 3 blau — NO
- 4 schwarz — NO
- 5 grün-gelb — ⊕

Connector: 5 pol Wago No 231-105/037-000

Cable length approx. 1,000 mm

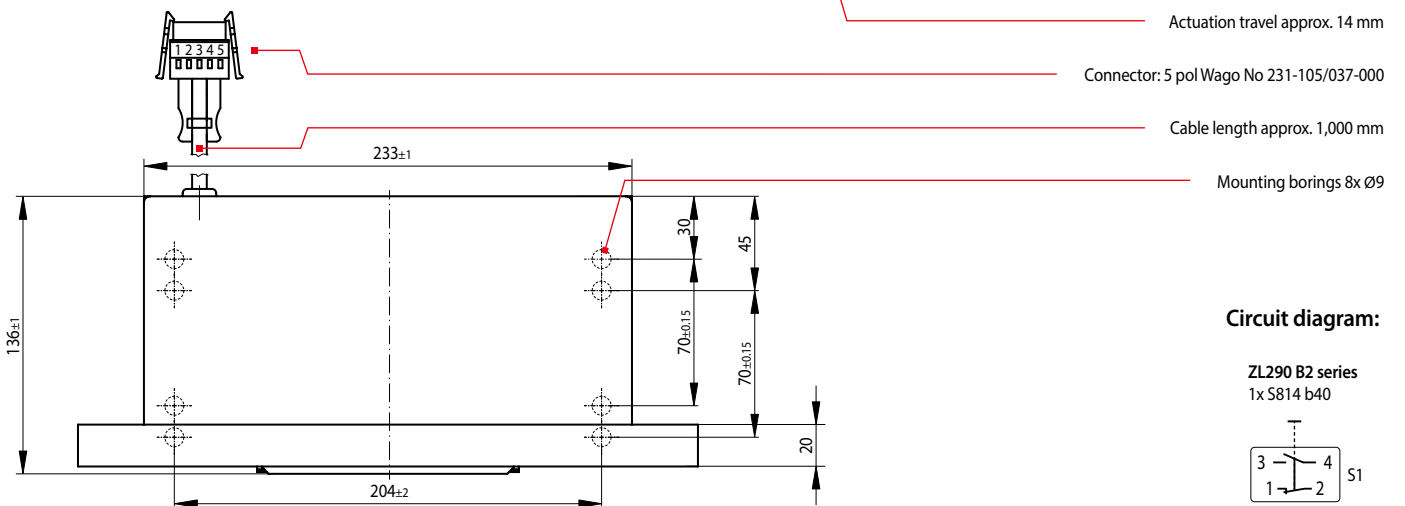

Circuit diagram:

ZL290 B2 series
1x S814 b40

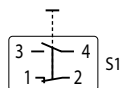

Schaltbau GmbH

For detailed information on our products and services visit our website – or give us a call!

Schaltbau GmbH
Hollerithstrasse 5
81829 Munich
Germany



Phone +49 89 9 30 05-0
Fax +49 89 9 30 05-350
Internet www.schaltbau-gmbh.com
e-Mail contact@schaltbau.de

with compliments:



Schaltbau GmbH manufactures in compliance with RoHS.



The production facilities of Schaltbau GmbH have been IRIS certified since 2008.



Certified to DIN EN ISO 14001 since 2002. For the most recent certificate visit our website.



Certified to DIN EN ISO 9001 since 1994. For the most recent certificate visit our website.

Electrical Components and Systems for Railway Engineering and Industrial Applications

Connectors

- Connectors manufactured to industry standards
- Connectors to suit the special requirements of communications engineering (MIL connectors)
- Charging connectors for battery-powered machines and systems
- Connectors for railway engineering, including UIC connectors
- Special connectors to suit customer requirements

Snap-action switches

- Snap-action switches with positive opening operation
- Snap-action switches with self-cleaning contacts
- Enabling switches
- Special switches to suit customer requirements

Contactors

- Single and multi-pole DC contactors
- High-voltage AC/DC contactors
- Contactors for battery powered vehicles and power supplies
- Contactors for railway applications
- Terminal bolts and fuse holders
- DC emergency disconnect switches
- Special contactors to suit customer requirements

Electrics for rolling stock

- Equipment for driver's cab
- Equipment for passenger use
- High-voltage switchgear
- High-voltage heaters
- High-voltage roof equipment
- Equipment for electric brakes
- Design and engineering of train electrics to customer requirements

We reserve the right to make technical alterations without prior notice.

For updated product information visit www.schaltbau-gmbh.com.

Issued 08-2019