

4

Electrics for Rolling Stock

PAD40

Passenger alarm devices
for rail vehicles

Installation and
maintenance instructions

Manual PAD40-M.en

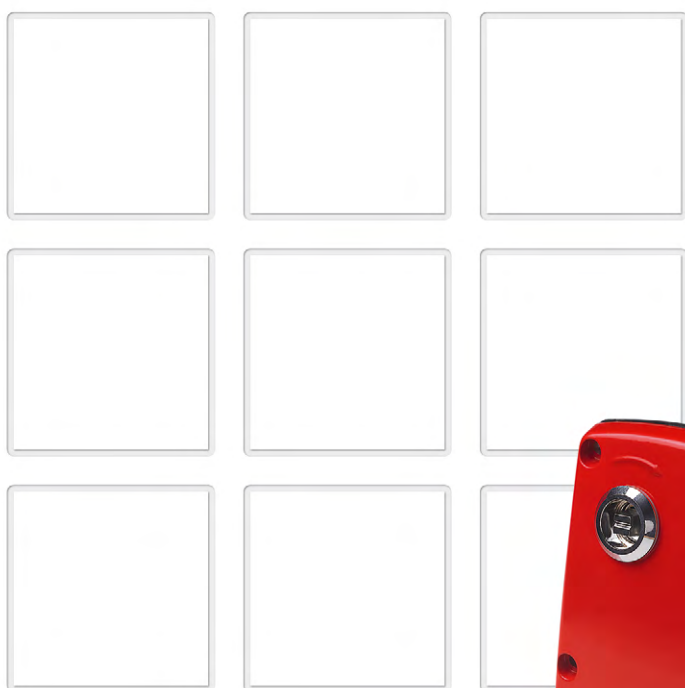

Contents

1. Important background information	3
1.1 Legal information	3
1.2 Other applicable documents	3
1.3 Training	3
1.4 Conventions for these operating and maintenance instructions	3
2. General and safety information	4
2.1 Observance of the operating and maintenance instructions	4
2.2 Duties of the operating company	4
2.3 Intended use	5
2.4 Misuse	5
2.5 Ambient conditions	5
3. Hazards and safety precautions	6
3.1 Electrical hazards	6
3.2 Mechanical hazards	6
4. Description	7
5. Installation	8
5.1 Checking parts for transport damage	8
5.2 Mounting cut-out and screw holes	8
5.3 Electrical connection	10
6. Commissioning/function check	12
7. Maintenance	13
7.1 Maintenance intervals	13
7.2 Replacing snap-action switch type S826	14
7.3 Replacing snap-action switch type S870	14
8. Spare parts	16
9. Type key	16
10. Technical data	17
11. Annex	18
11.1 Dimensions of passenger alarm device PAD40 – attachment from the rear	18
11.2 Dimensions of passenger alarm device PAD40 – attachment from the front	19
11.3 Dimensions of passenger alarm device PAD40-R20 – attachment from the rear	20
12. Notes	21

1. Important background information

1.1 Legal information

The instructions must not be reproduced, distributed, modified, communicated, translated into any other language or otherwise used, either in whole or in part, electronically or mechanically, without the express written permission of SCHALTBAU GmbH.
 SCHALTBAU GmbH shall not be liable for any damage resulting from failure or partial failure to observe the operating instructions.

1.2 Other applicable documents

Technical documents of purchased parts, material data sheets or checklists and reports, e.g. of completed servicing or maintenance work, are also applicable documents.

1.3 Training





SCHALTBAU GmbH offers additional customer training. Please contact us for further information.

1.4 Conventions for these operating and maintenance instructions

These operating and maintenance instructions outline the installation, operation and maintenance of the passenger alarm device.

Cross references are shown in **bold and italics** in these operating and maintenance instructions.

The following symbols are used to highlight safety instructions that are of particular importance.

 DANGER	Indicates a directly threatening dangerous situation. Death or severe injuries will result if it is not prevented.
 WARNING	Indicates a possibly dangerous situation. Death or severe injuries may result if it is not prevented.
 CAUTION	Indicates a possibly dangerous situation. Medium or minor injuries may result if it is not prevented.
ATTENTION	Indicates a possibly detrimental situation. If it is not prevented, assemblies, the system or property in its surroundings could be damaged.
	Indicates technical features and methods to simplify working or indicates information of particular importance.

2. General and safety information

The electrical device described here is a part of systems used in rolling stock and industrial plants. It has been designed and tested according to the relevant accepted codes of practice. In general, if electrical equipment is deployed incorrectly, operated incorrectly or inadequately maintained with unauthorised work being performed, the results could include severe harm to health or property damage. These instructions on operation, installation and maintenance of the device must be carefully followed.

Planning and execution of the mechanical and electrical installations, transport, erection and commissioning as well as maintenance and repair work must only be carried out by responsible specialists with appropriate technical knowledge. This applies both to compliance with the general installation and safety regulations for working on power installations (e.g. DIN, VDE) and also the correct use of approved tools and the use of personal protective equipment where necessary. Electrical devices must be protected against moisture and dust during installation, operation or storage.

In case of doubt, we recommend that you profit from the support and service provision of SCHALTBAU GmbH in respect of installation, commissioning and any service tasks that may arise.

2.1 Observance of the operating and maintenance instructions

- ▶ Personnel must read, understand and observe the operating and maintenance instructions for all work that arises.
- ▶ **Observe all safety instructions strictly and precisely!**

2.2 Duties of the operating company

- ▶ Observe all applicable national regulations, all safety, accident prevention and environmental protection regulations as well as the recognised technical rules for safe and correct working.
- ▶ Regularly check all fitted protection and safety equipment for correct function.
- ▶ Work on electrical equipment must only be carried out by a qualified electrician or by instructed persons under the supervision and control of a qualified electrician in accordance with electrical regulations.
- ▶ A specialist is someone who, on the basis of their technical training, knowledge and experience as well as knowledge of the relevant regulations, is able to assess the work assigned to them and identify possible dangers.
- ▶ The personnel must be clearly informed about who is responsible for servicing and maintenance work on the passenger alarm device.
- ▶ Personnel who are undergoing training, teaching, instruction or are in general education may only work on the passenger alarm device under the constant supervision of an experienced person.

2.3 Intended use

PAD40 series electrical passenger alarm devices for rail vehicles are designed to allow passengers to initiate emergency braking. Passenger alarm devices are designed in accordance with DIN EN 16334:2014.

In addition, passenger alarm devices are also suitable for many other applications in industry, such as on moving walkways and escalators. Passenger alarm devices may only be operated:

- ▶ If all protection devices are present, correctly installed and fully functional.
- ▶ If solely SCHALTBAU GmbH original spare parts are used in any servicing work.

2.4 Misuse

- ▶ Servicing work other than that outlined in these operating and maintenance instructions may only be carried out by SCHALTBAU GmbH service personnel.
- ▶ PAD40 series passenger alarm devices may not be converted or modified in any other way without prior written approval from SCHALTBAU GmbH. If this is contravened, the manufacturer will not be liable in anyway.
- ▶ Normal operation of the passenger alarm device may only take place if all protective devices are present, correctly installed and fully functional.
- ▶ If a PAD40 series passenger alarm device needs to be operated in modes that require temporary disabling of protective devices, this may only be performed by SCHALTBAU GmbH service personnel. During this work, the circumstances must be clearly indicated on the passenger alarm device, e.g. by a sign "Attention – maintenance work. Do not touch!" or, if necessary, access by third parties must be prevented. Once work is complete, all protective equipment must be properly reinstalled and checked for correct function.
- ▶ Any faults and damage observed must be reported and rectified immediately.
- ▶ None of the conditions of use such as voltages, currents, ambient conditions, etc., shown in section "10. **Technical data**" may be changed.
- ▶ Only personnel who fulfil the requirements given in these operating and maintenance instructions may work on the passenger alarm device.
- ▶ By-passing or jumpering of switches or other control components is not permitted.

2.5 Ambient conditions

ATTENTION

PAD40 series passenger alarm devices have been designed for special ambient conditions.

- ▶ Only operate passenger alarm devices under the ambient conditions stated in Section "10. **Technical data**".

3. Hazards and safety precautions

3.1 Electrical hazards

	⚠ DANGER
	<p>The passenger alarm device contains live components. Risk of electric shocks!</p> <ul style="list-style-type: none"> ▶ Switch the main switch in the vehicle to “OFF” before commencing work on the passenger alarm device. ▶ Ensure that the device is dead. ▶ Clearly demarcate your work area. ▶ Ensure that the main switch cannot be accidentally reactivated.

3.2 Mechanical hazards

	⚠ CAUTION
	<p>The passenger alarm device contains components that may be mechanically stressed. Risk of crushing if actuated in uninstalled condition!</p> <ul style="list-style-type: none"> ▶ Use suitable tools when working on components of the passenger alarm device. ▶ Secure components that are under mechanical stress before fitting or removing them.

	⚠ CAUTION
	<p>The passenger alarm device contains components with sharp edges. Risk of injury!</p> <ul style="list-style-type: none"> ▶ Use suitable tools for work on the passenger alarm device. ▶ Wear protective gloves when handling components with sharp edges.

4. Description

The PAD40 series passenger alarm device for rail vehicles, winner of the design award and offering maximum robustness, allows passengers to initiate emergency braking. In addition, the passenger alarm device is also suitable for many other applications in industry, such as on moving walkways and escalators.

PAD40 series passenger alarm devices are modular in structure and are available in various installation versions as well as with different switching elements, contact materials and connection types:

- ▶ Installation versions for attachment from the rear or front
- ▶ Equipment with snap-action switches of type S826 screw connection of type S870 with flat-plug connection
- ▶ Equipment with silver-plated or gold-plated contacts

Overview of PAD40/PAD40-R20 series passenger alarm devices

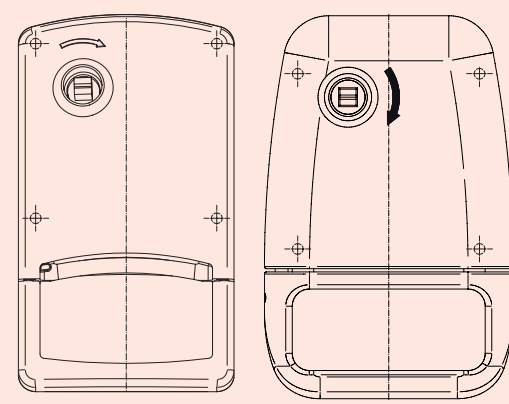
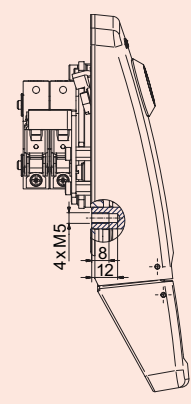
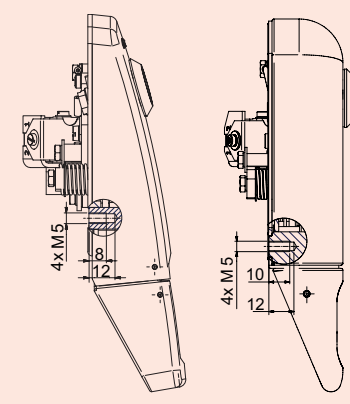
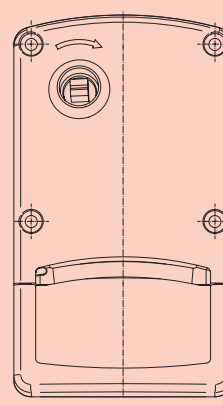
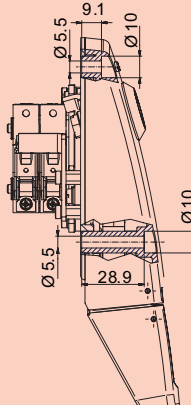
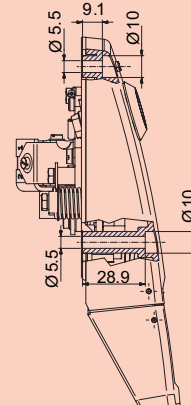
Installation version	Snap-action switch type S826 S1, S2, S3	Snap-action switch type S870 S5, S7, S8, S9
M1: Attachment from the rear 		
M2: Attachment from the front 		

- S1: 2x S826 e10/30, contacts: gold; connection: screws
 S2: 2x S826 e30, contacts: silver; connection: screws
 S3: 2x S826 e10, contacts: gold; connection: Screws with clamping plate
 S5: 2x S870 W2D4 a 013 A, contacts: gold; connection: flat plug
 S7: 2x S870 W2D1 a 013 A, contacts: silver; connection: flat plug
 S8: 3x S870 W1D1 a 013 A, contacts: silver; connection: flat plug
 S9: 3x S870 W1D4 a 013 A, contacts: gold; connection: flat plug
 (dimensions in mm)

5. Installation



⚠ DANGER

The passenger alarm device contains live components.
Risk of electric shocks!
Always observe the following safety rules before commencing work on the passenger alarm device:

- ▶ Disconnect
- ▶ Secure to prevent switching back on
- ▶ Check that a voltage-free state exists
- ▶ Clearly mark out the working area
- ▶ Besides the main electric circuits, also disconnect additional and auxiliary circuits.
- ▶ Cover or render inaccessible adjacent live parts

ATTENTION

During installation, ensure that dirt cannot penetrate the passenger alarm device from any construction work being carried out nearby.

5.1 Checking parts for transport damage

ATTENTION

In the event that parts are damaged, the functional safety of the passenger alarm device can no longer be guaranteed.

- ▶ Before commencing installation, check all parts for transport damage.
- ▶ Do not fit damaged parts.

5.2 Mounting cut-out and screw holes

A mounting cut-out in the mounting plate is required for installation of the passenger alarm device.

In addition, 4 screw holes (diameter 5.5 mm) or 4 threaded holes (M5) must also be made in the mounting plate, depending on the installation version.

The tightening torque and the length of the fixing screws must be determined by the user according to the materials used for the structure and according to the installation situation. The maximum tightening torque for customer-fitted fixing screws is 5 Nm. Screws must be secured against self-loosening with suitable screw-lock elements.

The dimensions of the cut-out and the position and arrangement of the screw holes/threaded holes are shown in the following figure.

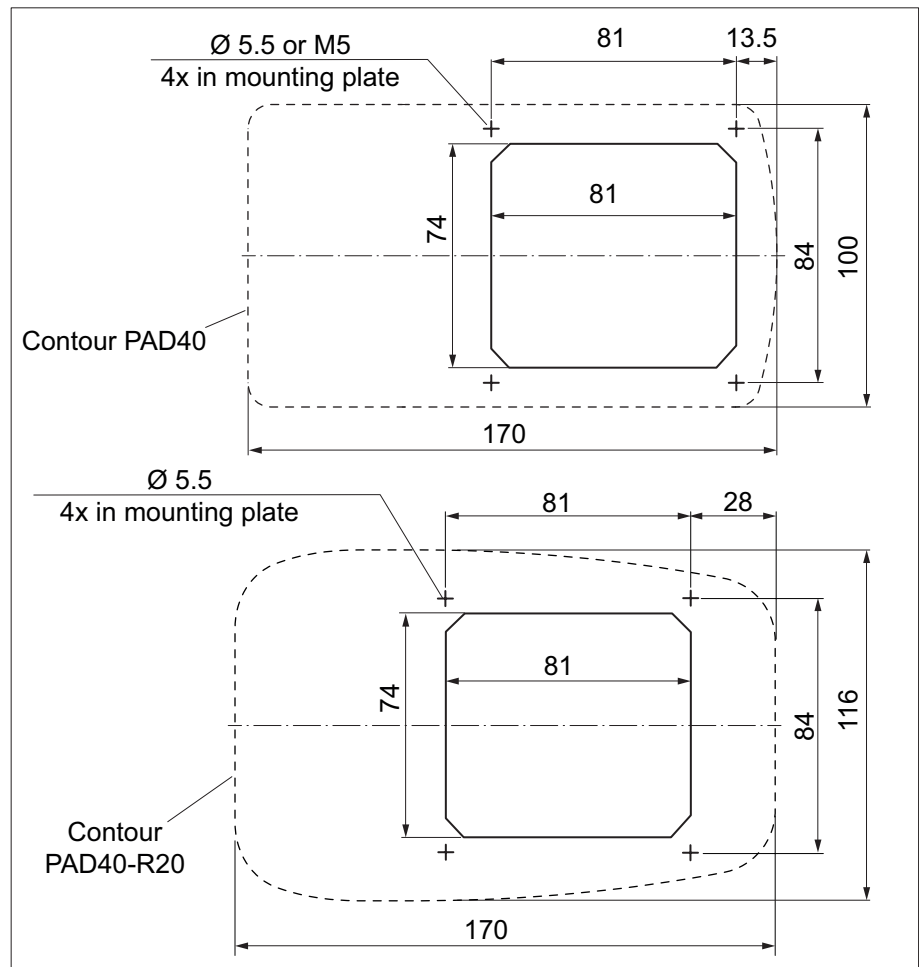

Dimensions of the cut-out and the position and arrangement of the screw holes/threaded holes (dimensions in mm)

Installation version M1

The screws are inserted into the screw holes (diameter 5.5 mm) in the mounting plate from behind and the PAD40/PAD40-R20 passenger alarm device **M1** R_S_B_ is screwed to the mounting plate.

Installation version M2

The PAD40 passenger alarm device **M2** R_S_B_ is screwed to the mounting plate from the front with 4 M5 screws. There are 2 attachment options:

- ▶ Either with 4 M5 threaded holes that have been drilled in the mounting plate;
- ▶ Or by inserting the screws through the screw holes (diameter 5.5 mm) in the mounting plate and securing the screws from behind with locking washers and nuts.

The complete dimensions of the passenger alarm devices can be found in the figures in the annex (**pages 18-20**).

5.3 Electrical connection

PAD40 with snap-action switches of type S826

In the case of passenger alarm devices equipped with snap-action switches of type S826, the electrical connection is established as a screw connection with cable lugs.

In the case of a screw connection with clamping plate, the cables can also be connected directly to stripped cable strands.

The position of the connections and the wiring diagram can be found in the following figure.

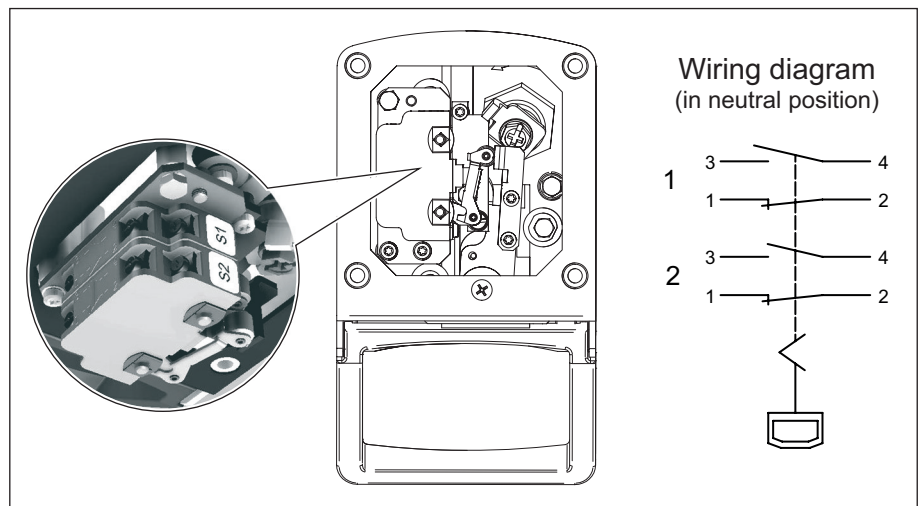

Electrical connection, PAD40 with snap-action switches of type S826

PAD40/PAD40-R20 with snap-action switches of type S870

In the case of passenger alarm devices equipped with snap-action switches of type S870, the electrical connection is established via a flat plug (6.3).

The wiring of the flat plug is carried out by the customer. The position of the connections and the wiring diagram can be found in the following figures.

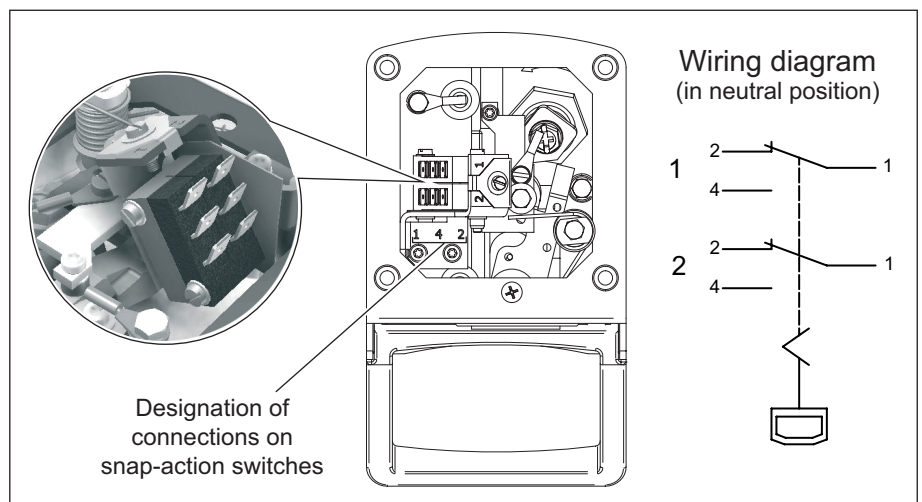

Electrical connection, PAD40 with snap-action switches of type S870

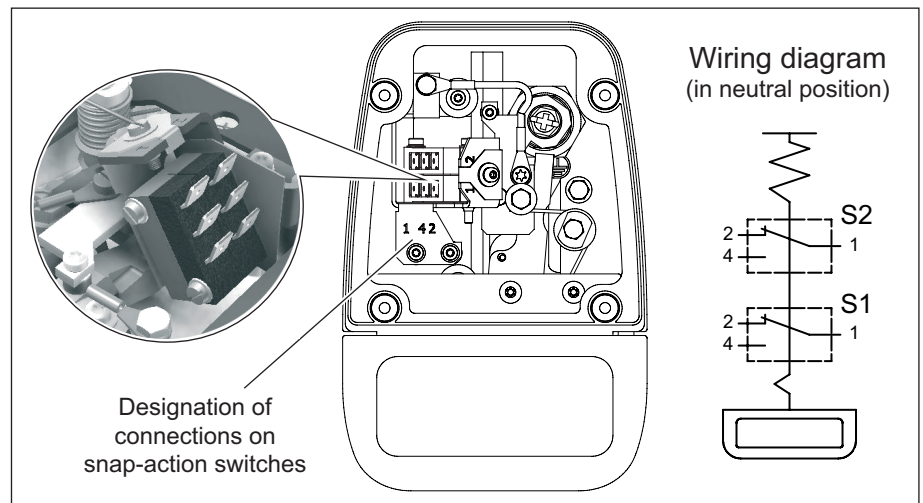

Electrical connection, PAD40-R20 with snap-action switches of type S870

6. Commissioning/function check

Once the electrical connection has been established and the device has been attached to the compartment wall, the passenger alarm device is ready to be commissioned.

Before commissioning and after all servicing and maintenance work, it is important to check the correction operation of the passenger alarm device.

Tools required

Depending on the version, one of the following reset keys is required to reset the passenger alarm device:

- ▶ R1: DB square
- ▶ R2: Triangle USA
- ▶ R3: Triangle 6.5 CNOMO type 1
- ▶ R6: Internal square UK

Prerequisites

The passenger alarm device has been attached to the compartment wall and electrically connected.

The handle of the passenger alarm device should not be sealed.

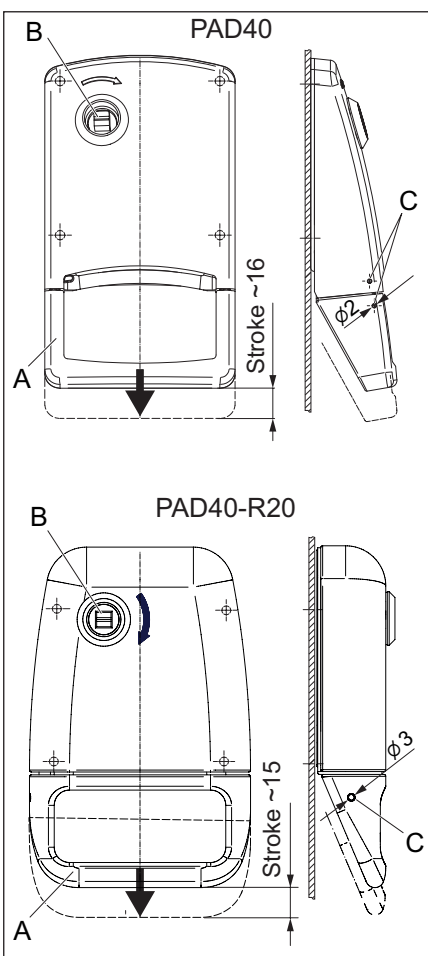

Function check (dimensions in mm)

Procedure

1. For the function check, pull the handle (A) of the passenger alarm device downwards.
 - Triggering is jerky
 - The snap-action switches have triggered
 - The handle is locked in the pulled position and can no longer be pushed in
2. To push in the handle, turn the reset key (B) approx. 30° clockwise with the appropriate key.
3. Then, push the handle back by hand while guiding the key back and forth.

ATTENTION

Ensure that the reset torque on the key is no more than 1 Nm! A higher reset torque can cause the passenger alarm device to fail.

Note on special design PAD40/PAD40-R20 Mx Rx Sx Bx SR with self-reset:

In the case of the special design SR passenger alarm device, the handle does not need to be pushed in by hand.

The handle is reset by turning the reset key (B) approx. 30° clockwise with the appropriate key. The handle then jumps back into the starting position automatically.

4. Finally, the handle can be sealed again at the designated holes (C).

7. Maintenance

During maintenance always comply with the necessary expert know-how provided in section “**2. General and safety information**”.

	⚠ DANGER
	<p>The passenger alarm device contains live components. Risk of electric shocks! Always observe the following safety rules before commencing work on the passenger alarm device:</p> <ul style="list-style-type: none"> ▶ Disconnect ▶ Secure to prevent switching back on ▶ Check that a voltage-free state exists ▶ Clearly mark out the working area ▶ Besides the main electric circuits, also disconnect additional and auxiliary circuits. ▶ Cover or render inaccessible adjacent live parts

The following is a list of all maintenance work that may be carried on the passenger alarm device by a specialist.

7.1 Maintenance intervals

The passenger alarm device is low maintenance. However, the condition of the device also depends on environmental influences. To ensure a lengthy service life for the passenger alarm device, the following regular checks/maintenance are recommended:

Check/maintenance	Interval
Carry out a function check (see Section “ 6. Commissioning/function check ” on <i>page 12</i>).	▶ Every six months
Replace snap-action switch S870 or S826	▶ Depending on the ambient conditions, but after 10 years of operation in any event

7.2 Replacing snap-action switch type S826



Required tools/resources

- ▶ PZ1 screwdriver for Philips screws
- ▶ Testing buzzer as a continuity/circuit tester

Removal

1. Unscrew and remove the passenger alarm device from the mounting plate.
2. Remove the cable by undoing the contact screws on the snap-action switches.
3. Remove the duoclips (A) and pull the snap-action switches (B) from the mounting.

Installation

1. Push a new snap-action switch (B) onto the mounting. Note the position of the roller lever (as shown in the figure).
2. Secure the snap-action switches (B) with the new duoclips (A).
3. Re-clamp the cable in the snap-action switch contacts and screw tightly.
4. Check for the correct wiring and function of the replaced snap-action switches using the testing buzzer and log!
5. Reattach the passenger alarm device to the mounting plate.
6. Finally, carry out a function check (see Section “**6. Commissioning/function check**” on **page 12**).

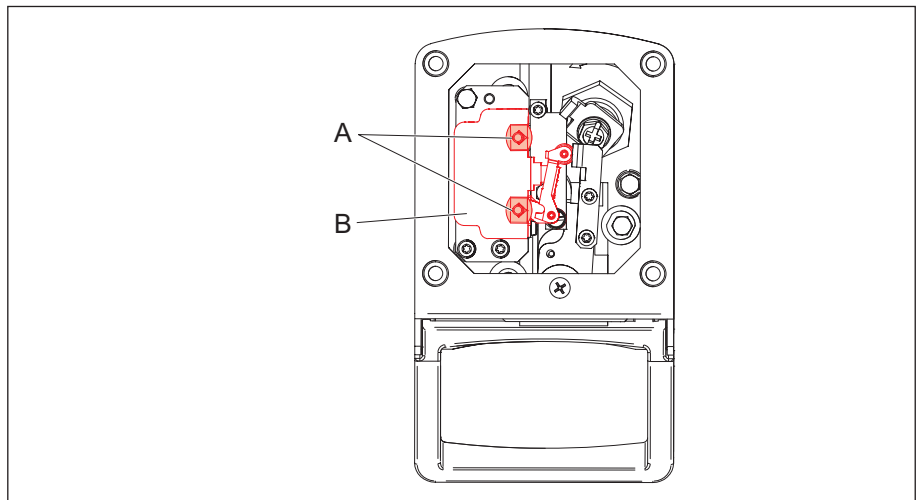

Replacing snap-action switch type S826

7.3 Replacing snap-action switch type S870



Required tools/resources

- ▶ Screwdriver no. 1 for slotted screws
- ▶ Testing buzzer as a continuity/circuit tester

Removal

1. Unscrew and remove the passenger alarm device from the mounting plate.
2. Remove the cable by undoing the flat plug from the snap-action switch contacts (A).
3. Undo the fixing screws (C) from the snap-action switches and remove the snap-action switches (B).

Installation

1. Insert new snap-action switches (B).
2. Screw on the snap-action switches (B) with fixing screws (C) lightly, then tighten to a torque of max. 0.25 Nm.
3. Attach a flat plug to the contacts (A) on the snap-action switches.
4. Check for the correct wiring and function of the replaced snap-action switches using the testing buzzer and log!
5. Screw the passenger alarm device back onto the mounting plate.
6. Finally, carry out a function check (see Section “6. Commissioning/function check” on page 12).

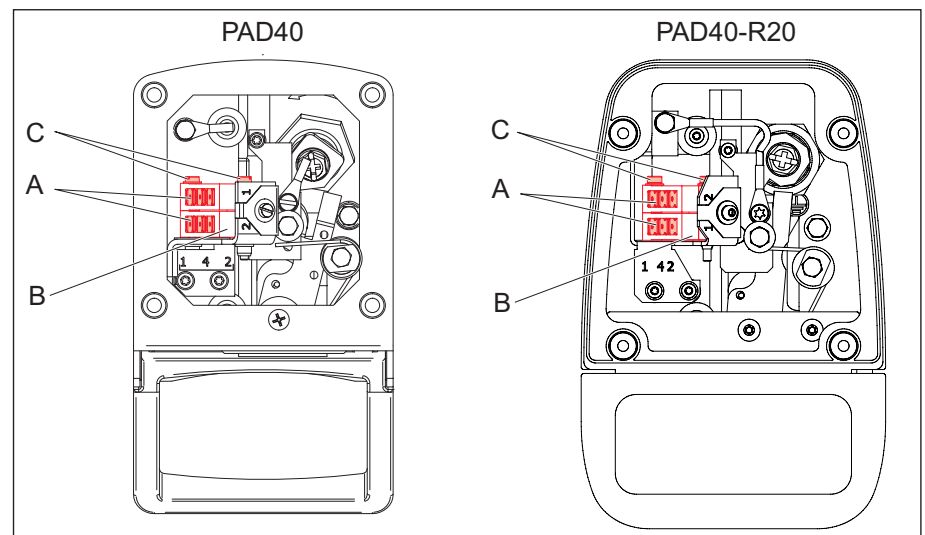

Replacing snap-action switch type S870

8. Spare parts

Depending on the passenger alarm device type, the following snap-action switches are available as spare parts:

Passenger alarm device type	Snap-action switch designation	Number	Article no.
PAD40 Mx Rx S1 Bx	S826 e 10/30	2x	1-1522-258265
PAD40 Mx Rx S2 Bx	S826 e 30	2x	1-1522-105912
PAD40 Mx Rx S3 Bx	S826 e 10	2x	1-1522-103109
The following are also required to replace the snap-action switches S1, S2, S3:	DC-800, duoclip	2x	1-5341-436681
PAD40/PAD40-R20 Mx Rx S5 Bx	S870 W2D4 a 013 A	2x	1-1570-205828
PAD40/PAD40-R20 Mx Rx S7 Bx	S870 W2D1 a 013 A	2x	1-1570-205817
PAD40 Mx Rx S8 Bx	S870 W1D1 a 013 A	3x	1-1570-304015
PAD40 Mx Rx S9 Bx	S870 W1D4 a 013A	3x	1-1570-301029

9. Type key

		Example:	PAD40/	M1	R1	S1	B1	SR
Series	_____							
PAD40	Electrical passenger alarm device							
PAD40-R20								
Installation version	_____							
M1	Attachment from the rear, M5 thread							
M2	Attachment from the front, 5.5 mm hole							
Reset element	_____							
R1	DB square							
R2	Triangle USA							
R3	Triangle 6.5 CNOMO type 1							
R6	Internal square UK							
Switching element	_____							
S1	2x S826 e 10/30, gold contacts, screw connection							
S2	2x S826 e30, silver contacts, screw connection							
S3	2x S826 e10, gold contacts, screw connection with clamping plate							
S5	2x S870 W2D4 a 013 A, gold contacts, flat-plug connection							
S7	2x S870 W2D1 a 013 A, silver contacts, flat-plug connection							
S8	3x S870 W1D1 a 013 A, silver contacts, flat-plug connection							
S9	3x S870 W1D4 a 013 A, gold contacts, flat-plug connection							
Labelling/colour**	_____							
B0	without/red (RAL 3020) standard design							
B1	German/red (RAL 3020)							
Special design	_____							
SR	self-resetting, optional							

**Other colours and country-specific labelling on request

10. Technical data

	PAD40	PAD40-R20
Mechanical service life	>1000 actuations	
Rated voltage	to 150 V/DC	
Rated insulation voltage	250 V	
max. therm. continuous current	3A (S870); 10A (S826)	
Protection class DIN EN 60529	IP42 (user side)	
Operating temperature range	-40 °C to +70 °C	-20 °C to +40 °C
Storage temperature range	-40 °C to +70 °C	-20 °C to +40 °C
Air humidity	Store dry (max. air humidity 90%)	
Gross weight	approx. 700 g	
Actuation force DIN EN 16334	65 N to 120 N (not sealed)	
Colour	RAL 3020; red or customer specification	
Snap-action switches *	2x S870 or 2x S826 or 3x S870	2x S870
Contact type	Changeover contact	
Housing material	Aluminium pressure casting	
Shock/vibration resistance	DIN EN 61373	
Standards	DIN EN 60077, DIN EN 60947-5-1	

* For technical details about the snap-action switches, see customer catalogue D26 (S826) or D70 (S870)

11. Annex

11.1 Dimensions of passenger alarm device PAD40 – attachment from the rear

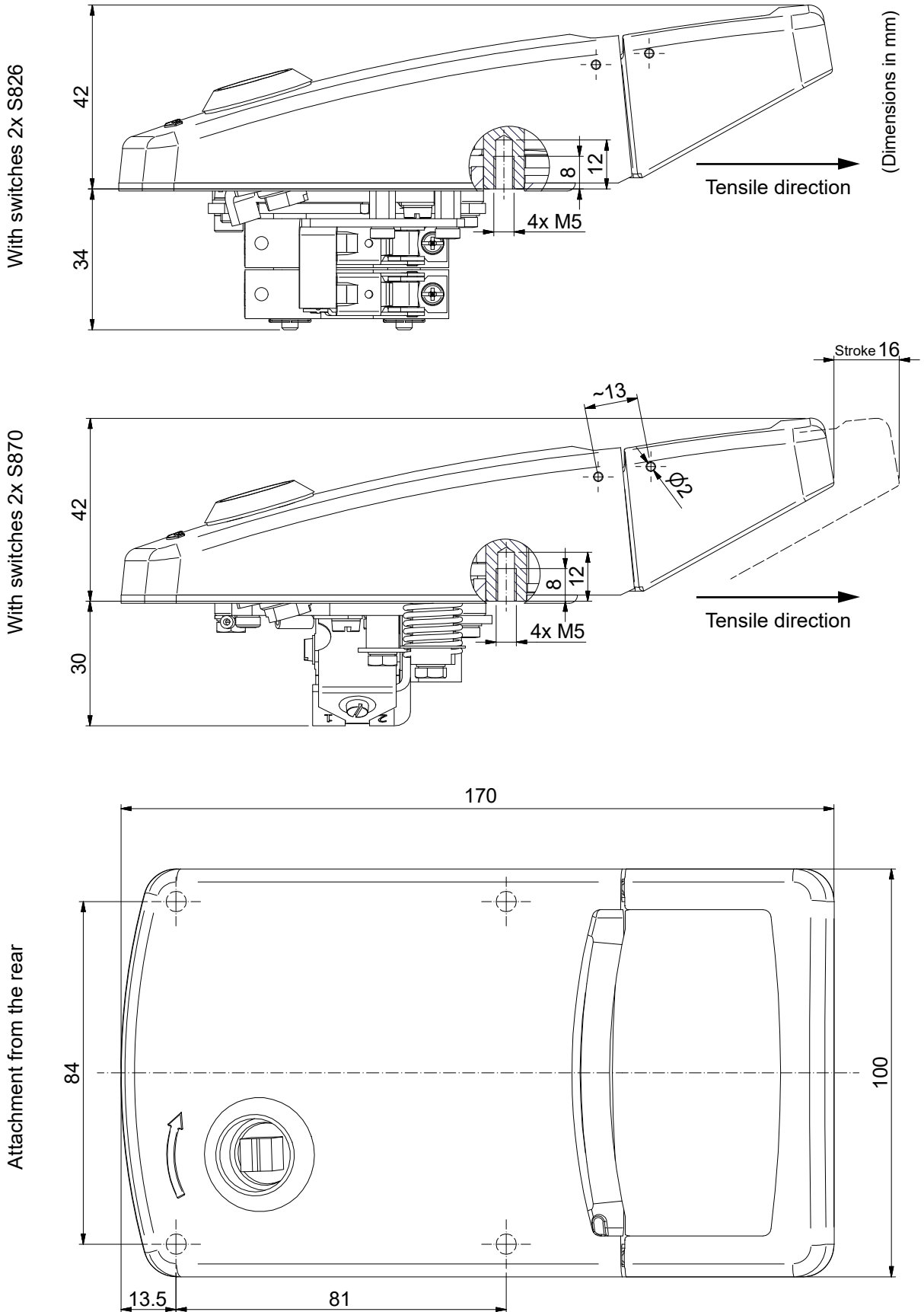

11.2 Dimensions of passenger alarm device PAD40 – attachment from the front

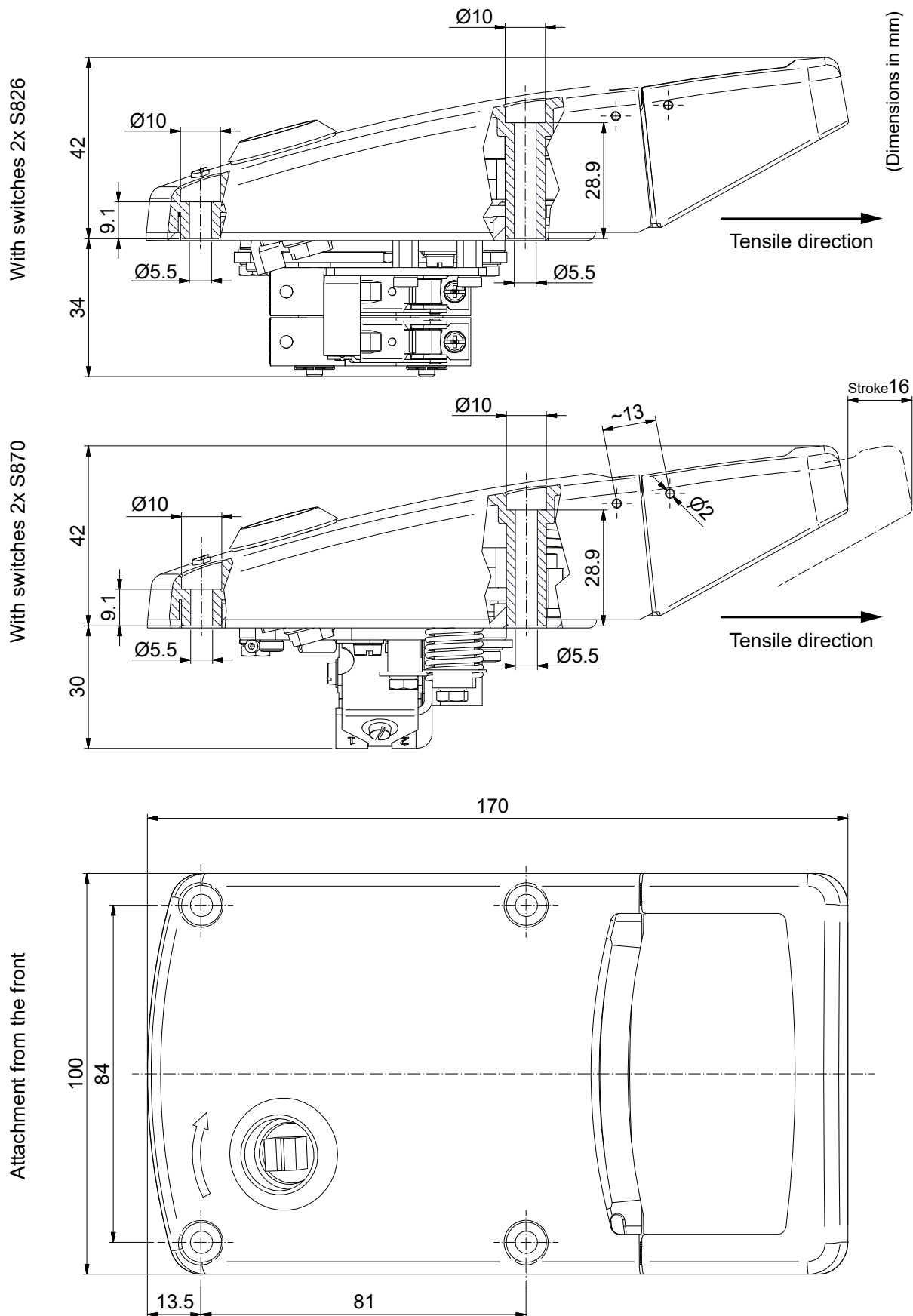

11.3 Dimensions of passenger alarm device PAD40-R20 – attachment from the rear

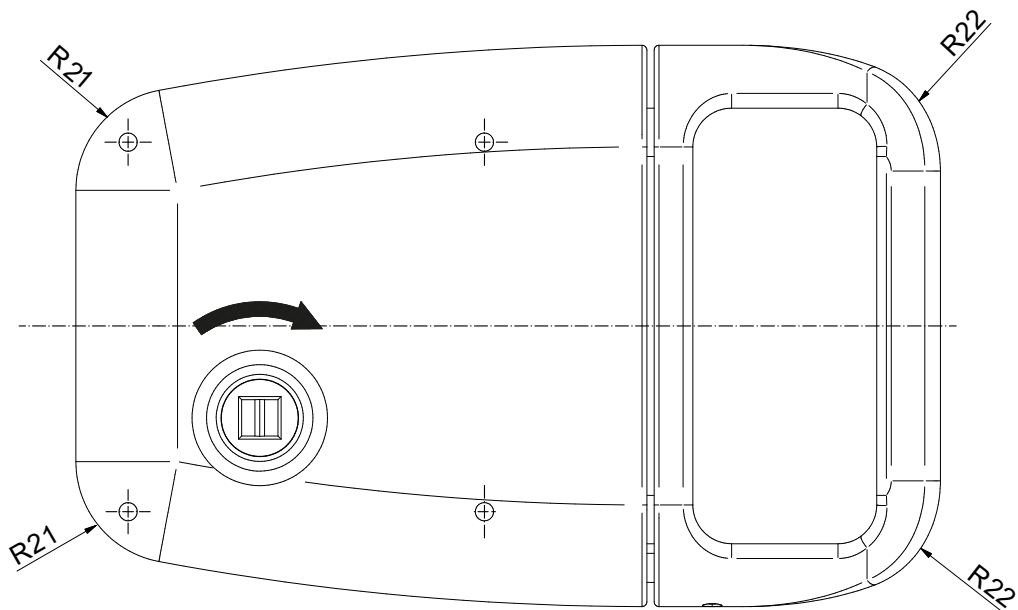
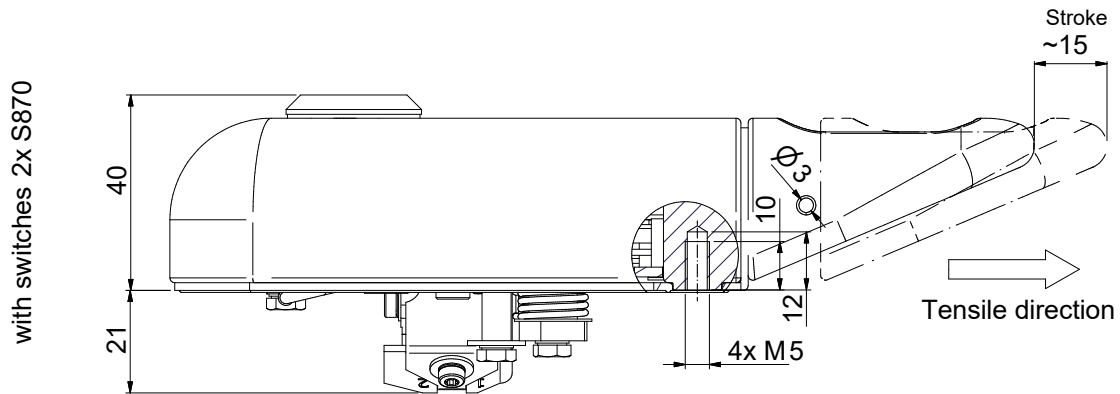
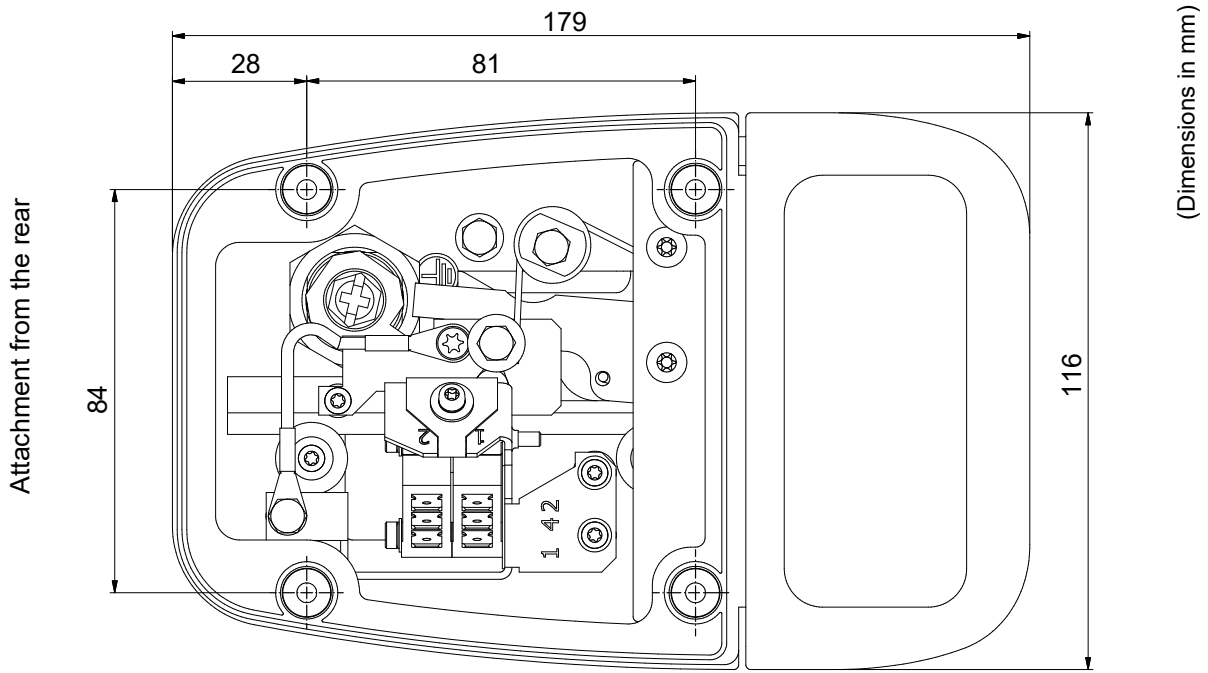

12. Notes

Schaltbau GmbH

For detailed information on our products and services visit our website – or give us a call!

Schaltbau GmbH
Hollerithstrasse 5
81829 Munich
Germany



Phone +49 89 9 30 05-0
Fax +49 89 9 30 05-350
Internet www.schaltbau.com
e-Mail contact@schaltbau.de

with compliments:



The production facilities of Schaltbau GmbH have been IRIS certified since 2008.



Certified to DIN EN ISO 14001 since 2002. For the most recent certificate visit our website.



Certified to DIN EN ISO 9001 since 1994. For the most recent certificate visit our website.

Electrical Components and Systems for Railway Engineering and Industrial Applications

Connectors

- Connectors manufactured to industry standards
- Connectors to suit the special requirements of communications engineering (MIL connectors)
- Charging connectors for battery-powered machines and systems
- Connectors for railway engineering, including UIC connectors
- Special connectors to suit customer requirements

Snap-action switches

- Snap-action switches with positive opening operation
- Snap-action switches with self-cleaning contacts
- Snap-action switch made of robust polyetherimide (PEI)
- Snap-action switch with two galvanically isolated contact bridges
- Special switches to suit customer requirements

Contactors Emergency disconnect switches

- Single and multi-pole DC contactors
- High-voltage AC/DC contactors
- Contactors for battery powered vehicles and power supplies
- Contactors for railway applications
- Terminal bolts and fuse holders
- DC emergency disconnect switches
- Special contactors to suit customer requirements

Electrics for rolling stock

- Equipment for driver's cab
- Equipment for passenger use
- High-voltage switchgear
- High-voltage heaters
- High-voltage roof equipment
- Equipment for electric brakes
- Design and engineering of train electrics to customer requirements